



# Operator's Manual

5G Device Modem



**FORTINET DOCUMENT LIBRARY**

<https://docs.fortinet.com>

**FORTINET VIDEO LIBRARY**

<https://video.fortinet.com>

**FORTINET BLOG**

<https://blog.fortinet.com>

**CUSTOMER SERVICE & SUPPORT**

<https://support.fortinet.com>

**FORTINET TRAINING & CERTIFICATION PROGRAM**

<https://www.fortinet.com/training-certification>

**FORTINET TRAINING INSTITUTE**

<https://training.fortinet.com>

**FORTIGUARD LABS**

<https://www.fortiguard.com>

**END USER LICENSE AGREEMENT**

<https://www.fortinet.com/doc/legal/EULA.pdf>

**FEEDBACK**

Email: [techdoc@fortinet.com](mailto:techdoc@fortinet.com)



February 19, 2026

5G Device Modem Operator's Manual

# TABLE OF CONTENTS

<b>Introduction</b> .....	<b>6</b>
<b>FG/FWF/FGR variants 5G modem features matrix</b> .....	<b>7</b>
<b>Feature descriptions</b> .....	<b>8</b>
3G/4G/5G handover .....	8
Manual modem firmware upgrade .....	8
Scheduled 5G modem firmware upgrade .....	8
Carrier-config switch .....	9
GPS location .....	9
Dual SIM card slots .....	9
SIM card switch .....	9
Dual SIM LEDs .....	9
<b>Installation</b> .....	<b>10</b>
Antenna mapping .....	10
Hardware installation .....	11
Check modem driver status .....	11
Check modem status .....	14
Use 5G services .....	14
<b>Configuration</b> .....	<b>16</b>
Configure the modem from FortiGate GUI .....	16
Configure the modem from FortiGate Console .....	17
Connect your computer to FortiGate .....	17
Create a data plan .....	18
Configure the modem .....	19
<b>Execute 5g-modem commands</b> .....	<b>25</b>
execute 5g-modem carrier-config .....	25
execute 5g-modem carrier-config switch <carrier config index> .....	26
execute 5g-modem cold-reboot .....	26
execute 5g-modem reboot .....	27
execute 5g-modem sim-switch .....	27
<b>Diagnose system commands</b> .....	<b>29</b>
diagnose sys 5g-modem modem-details .....	29
diagnose sys 5g-modem sim-info .....	30
diagnose sys 5g-modem signal-info .....	30
diagnose sys 5g-modem data-session-info .....	31
diagnose sys 5g-modem traffic-status .....	32
diagnose sys 5g-modem gps-info .....	32
<b>Diagnose test application commands</b> .....	<b>34</b>
diagnose test application nr5gd 1 .....	36
diagnose test application nr5gd 2 .....	37
diagnose test application nr5gd 3 .....	37
diagnose test application nr5gd 4 .....	37

diagnose test application nr5gd 5 .....	37
diagnose test application nr5gd 6 .....	38
diagnose test application nr5gd 7 .....	38
diagnose test application nr5gd 8 .....	38
diagnose test application nr5gd 9 .....	38
diagnose test application nr5gd 10 .....	39
diagnose test application nr5gd 11 .....	39
diagnose test application nr5gd 12 .....	39
diagnose test application nr5gd 13 .....	39
diagnose test application nr5gd 14 .....	40
diagnose test application nr5gd 15 .....	42
diagnose test application nr5gd 22 .....	42
diagnose test application nr5gd 23 .....	42
diagnose test application nr5gd 24 .....	42
diagnose test application nr5gd 25 .....	43
diagnose test application nr5gd 26 .....	43
diagnose test application nr5gd 27 .....	44
diagnose test application nr5gd 28 .....	44
diagnose test application nr5gd 29 .....	45
diagnose test application nr5gd 30 .....	45
<b>IPv6 for 5G WWAN interface .....</b>	<b>46</b>
IPv6 auto-configuration (SLAAC) .....	46
Verifying IPv6 connectivity .....	46
Viewing data session information .....	47
IPv6 event logging .....	49
<b>Using eSIM .....</b>	<b>50</b>
Preparation .....	50
CLI commands for eSIM .....	50
default .....	50
set esim enable .....	51
execute 5g-modem esim profile download <activation code> .....	52
execute 5g-modem esim profile list .....	53
execute 5g-modem esim profile enable .....	53
execute 5g-modem esim profile disable .....	55
execute 5g-modem esim profile delete .....	56
unset esim .....	57
eSIM log .....	62
Supported eSIM providers .....	62
<b>MIBs .....</b>	<b>64</b>
Download MIB files .....	64
Enable SNMP support .....	65
Create SNMP community .....	65
Allow SNMP access .....	66
Configure MIB browser .....	67
Browse for MIB entries .....	68

---

<b>Syslog</b> .....	<b>70</b>
<b>Firmware upgrade</b> .....	<b>71</b>
<b>Change log</b> .....	<b>72</b>

# Introduction

The FortiGate/FortiWiFi 50G-5G (FG/FWF 50G-5G), FortiGate Rugged 60G-5G-Series (FGR-60G-5G), and FortiGate Rugged 70G-5G-Dual (FGR-70G-5G-DUAL) devices come with a built-in 5G modem to provide additional Internet connection and/or a redundant WAN link for its users. This *Manual* discusses how to configure the built-in 5G modem as the Internet access interface.

---

Before you start setting up your Fortinet 5G device, be sure to keep the following in mind:



- To provide Internet connectivity to end devices on your network through the LAN ports, your FortiGate/FortiWiFi devices must operate in NAT mode; it does not work in transparent mode.
  - The term "5G modem" means a 5G-capable modem.
  - This manual covers the configuration of the *internal* 5G modem only. For configuration of the other features of your FortiGate/FortiWiFi devices, refer to the latest FortiGate/FortiOS and FortiWiFi documentation.
  - We strongly recommend against putting any USB modem into the external USB port because doing so might confuse the system and cause the built-in 5G modem to malfunction. On the other hand, if you clearly understand what you are doing, you can put a USB modem running the PPP protocol in the external USB port.
- 

This *Manual* is prepared for users of FG/FWF 50G-5G, FGR-60G-5G-Series, and FGR-70G-5G-DUAL devices with the built-in 5G modem.

For FG/FWF 50G-5G and FGR-70G-5G-DUAL, the instructions are based on the FortiOS 7.0.15 GA release; for FGR-60G-5G-Series, the instructions are based on FortiOS 7.4.8, build 6391 with the Auralo eSIM.

# FG/FWF/FGR variants 5G modem features matrix



This *Manual* is based on FortiGate/FortiWiFi 50G-5G, FortiGate Rugged 60G-5G-Series, and FortiGate Rugged 70G-5D-Dual device models.

Features	FortiGate/FortiWiFi/FortiGate Rugged Models		
	FG/FWF-50G-5G	FGR-60G-5G-Series	FGR-70G-5G-DUAL
Modem	FN990A28-HP	FN990A28-HP	FN990A28-HP
5G	x	x	x
4G LTE	x	x	x
3G	x	x	x
3G/4G/5G handover	x	x	x
Manual firmware upgrade	x	x	x
Scheduled firmware upgrade	x	x	x
Carrier-config switch	x	x	x
GPS	x	x	x
Dual SIM cards	x	x	x
SIM card auto-switching	x	x	x
Dual SIM LED	n/a	x	x
Number of modems	1	1	2
eSIM	n/a	x	n/a

# Feature descriptions

- [3G/4G/5G handover on page 8](#)
- [Manual modem firmware upgrade on page 8](#)
- [Scheduled 5G modem firmware upgrade on page 8](#)
- [Carrier-config switch on page 9](#)
- [GPS location on page 9](#)
- [Dual SIM card slots on page 9](#)
- [SIM card switch on page 9](#)
- [Dual SIM LEDs on page 9](#)

## 3G/4G/5G handover

The Fortinet 5G modem supports 3G/4G/5G connectivity. Because 5G connection is always preferred, the modem will try to switch back to the 5G network whenever the signal is strong enough. Although handover to the 5G network is the default, this behavior may not be very explicit sometimes.

To ensure that the modem always switches back to the 5G network in a prompt manner, FortiOS provides the "set network-type" option to enable users to set up the connection mode that the SIM card supports. Refer to [set network-type on page 20](#) for details.

## Manual modem firmware upgrade

The modem is preloaded with firmware for different carriers across the globe, but you can upgrade to the latest version of the 5G modem firmware to meet your 5G networking needs. For more information, visit [Manual firmware upgrade](#).

## Scheduled 5G modem firmware upgrade

In addition to upgrading the modem firmware manually, you can also set firmware upgrade schedules from FortiGuard to let FortiOS automatically query the FortiCloud server for new firmware upgrade and to initiate the upgrade process. For more information, visit [Scheduled auto firmware upgrade from FortiGuard](#).

## Carrier-config switch

The 5G modem is preloaded with multiple carrier configurations. You can let FortiOS instruct the modem to automatically switch to the corresponding carrier configuration according to the SIM card it has detected or manually select the carrier configuration of your choice. See [set carrier-config on page 23](#).

## GPS location

The 5G modem comes with GPS location capability. It provides GPS service regardless of the SIM card used, as long as there is good GPS satellite signal.

## Dual SIM card slots

For SP5-based 5G models, there are two physical SIM slots available which enable the unit to hold two SIM cards simultaneously, even though only one SIM card will be used at any given time.

## SIM card switch

FortiOS is able to choose the valid SIM card to be used regardless of the slot in which the SIM card is inserted. If both SIM card slots are filled, FortiOS will choose the one with connectivity. It automatically monitors the SIM card status to ensure its proper operation. If it detects that the SIM card is in error, absent, or unable to connect to the network, it will switch to the other SIM card. Refer to [execute 5g-modem sim-switch on page 27](#) for details.

## Dual SIM LEDs

For certain models, there are LED lights in the front to indicate the active SIM slot that the unit is currently using.

# Installation

- Antenna mapping on page 10
- Hardware installation on page 11
- Check modem driver status on page 11
- Check modem status on page 14
- Use 5G services on page 14

## Antenna mapping

The following diagram highlights the connectors for different types of external antennas.

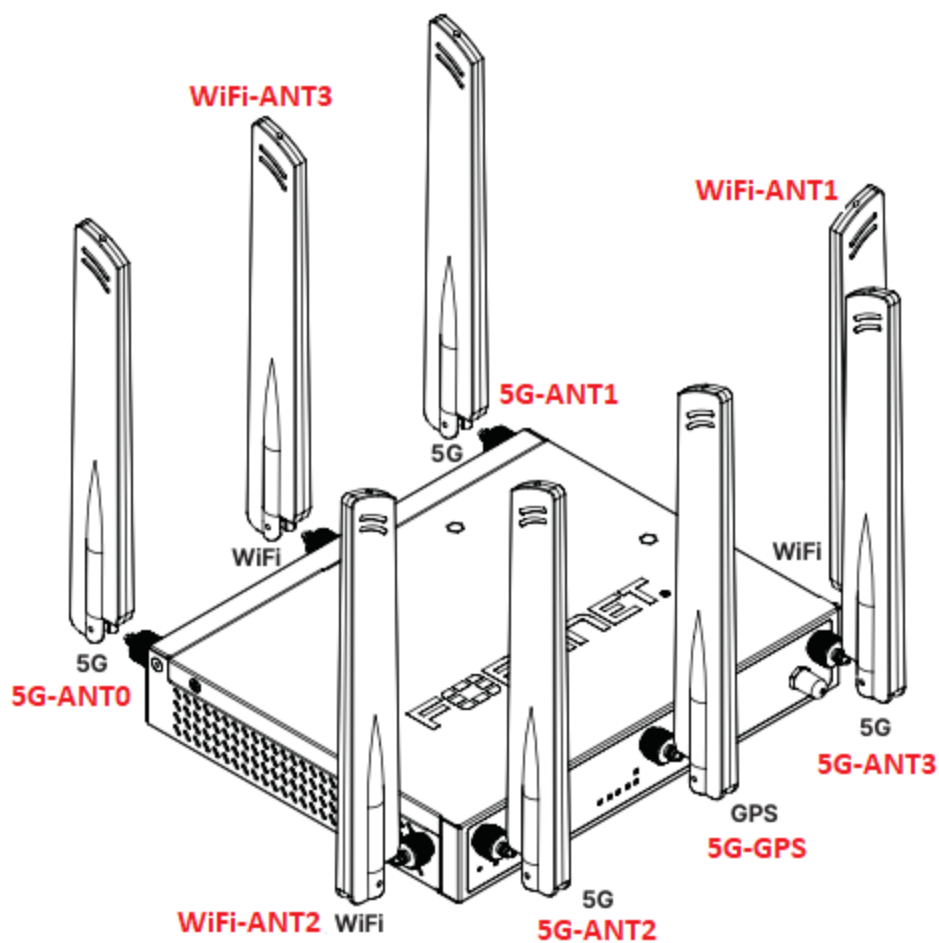

## Hardware installation



Before starting the installation, be sure to pay attention to the following:

- The flat antennas are for the 5G modem and must be mounted on both sides of the chassis.
- The WiFi antennas are on the backside. For a non-WiFi unit, there are no WiFi antennas on the backside.
- If the GPS connector is present, be sure to attach it as well.

1. Attach the WiFi and 5G antennas to the unit. Refer to the notes above and [Antenna mapping on page 10](#).
2. Use the power cable provided in the package to connect the device to a power outlet.
3. Use an Ethernet cable to connect the device to your network.
4. Use another Ethernet cable to connect the device (via any port from port1 through port3) to your PC, hub, or switch.

## Check modem driver status

```
FortiWiFi-50G-5G # execute usb-device list
```

```
T: Bus=01 Lev=00 Prnt=00 Port=00 Cnt=00 Dev#= 1 Spd=480 MxCh= 1
B: Alloc= 0/800 us ( 0%), #Int= 0, #Iso= 0
D: Ver= 2.00 Cls=09(hub ) Sub=00 Prot=01 MxPS=64 #Cfgs= 1
P: Vendor=1d6b ProdID=0002 Rev= 4.19
S: Manufacturer=Linux 4.19.13 xhci-hcd
S: Product=xHCI Host Controller
S: SerialNumber=f3008000.usb3
C:* #Ifs= 1 Cfg#= 1 Atr=e0 MxPwr= 0mA
I:* If#= 0 Alt= 0 #EPs= 1 Cls=09(hub ) Sub=00 Prot=00 Driver=hub
E: Ad=81(I) Atr=03(Int.) MxPS= 4 Iv1=256ms

T: Bus=01 Lev=01 Prnt=01 Port=00 Cnt=01 Dev#= 3 Spd=480 MxCh= 2
D: Ver= 2.00 Cls=09(hub ) Sub=00 Prot=02 MxPS=64 #Cfgs= 1
P: Vendor=05e3 ProdID=0610 Rev=61.60
S: Product=USB2.0 Hub
C:* #Ifs= 1 Cfg#= 1 Atr=e0 MxPwr=100mA
I: If#= 0 Alt= 0 #EPs= 1 Cls=09(hub ) Sub=00 Prot=01 Driver=hub
E: Ad=81(I) Atr=03(Int.) MxPS= 1 Iv1=256ms
I:* If#= 0 Alt= 1 #EPs= 1 Cls=09(hub ) Sub=00 Prot=02 Driver=hub
E: Ad=81(I) Atr=03(Int.) MxPS= 1 Iv1=256ms

T: Bus=02 Lev=00 Prnt=00 Port=00 Cnt=00 Dev#= 1 Spd=10000 MxCh= 1
B: Alloc= 0/800 us ( 0%), #Int= 0, #Iso= 0
D: Ver= 3.10 Cls=09(hub ) Sub=00 Prot=03 MxPS= 9 #Cfgs= 1
P: Vendor=1d6b ProdID=0003 Rev= 4.19
```



```

E: Ad=86(I) Atr=02(Bulk) MxPS=1024 Iv1=0ms
E: Ad=04(0) Atr=02(Bulk) MxPS=1024 Iv1=0ms
I:* If#= 5 Alt= 0 #EPs= 3 Cls=ff(vend.) Sub=ff Prot=40 Driver=option
E: Ad=89(I) Atr=03(Int.) MxPS= 10 Iv1=32ms
E: Ad=88(I) Atr=02(Bulk) MxPS=1024 Iv1=0ms
E: Ad=05(0) Atr=02(Bulk) MxPS=1024 Iv1=0ms
I:* If#= 6 Alt= 0 #EPs= 3 Cls=ff(vend.) Sub=ff Prot=40 Driver=option
E: Ad=8b(I) Atr=03(Int.) MxPS= 10 Iv1=32ms
E: Ad=8a(I) Atr=02(Bulk) MxPS=1024 Iv1=0ms
E: Ad=06(0) Atr=02(Bulk) MxPS=1024 Iv1=0ms

T: Bus=05 Lev=00 Prnt=00 Port=00 Cnt=00 Dev#= 1 Spd=480 MxCh= 1
B: Alloc= 0/800 us ( 0%), #Int= 0, #Iso= 0
D: Ver= 2.00 Cls=09(hub ) Sub=00 Prot=01 MxPS=64 #Cfgs= 1
P: Vendor=1d6b ProdID=0002 Rev= 4.19
S: Manufacturer=Linux 4.19.13 dummy_hcd
S: Product=Dummy host controller
S: SerialNumber=dummy_hcd.0
C:* #Ifs= 1 Cfg#= 1 Atr=e0 MxPwr= 0mA
I:* If#= 0 Alt= 0 #EPs= 1 Cls=09(hub ) Sub=00 Prot=00 Driver=hub
E: Ad=81(I) Atr=03(Int.) MxPS= 4 Iv1=256ms

```

As highlighted in red in the screen output above, the vendor ID of the modem is 1bc7, the product ID is 1070, and the modem name is FN990.

Look for the following lines. These descriptors are for the USB interfaces 0, 2, and 3, and are bound to the USB driver option, which means they are USB serial ports. Beware that they are enumerated as `/dev/ttyusb0~ttyusb2` in the system. The naming conventions in FortiOS are different from those in the traditional Linux kernel. Interface 2 in the output is bound to USB driver `qmi_wwan`. This is the interface that handles the real network data transmission for this modem. It is attached to an Ethernet mode interface `wwan` in FortiOS, as shown in the following code:

```
I:* If#= 2 Alt= 0 #EPs= 3 Cls=ff(vend.) Sub=ff Prot=50 Driver=qmi_wwan
```

Interfaces 0, 2, and 3 for this specific modem are DM/GPS/Modem ports. The DM port is reserved for low-level debugging operations; the GPS port outputs location-related information; the Modem port, also known as the AT Command Interface, lets you issue AT commands for status and debugging purposes.

The following command displays the modem data interface.

```

FortiWiFi-50G-5G # fnsysctl ifconfig wwan
wwan Link encap:Ethernet HWaddr 0A:00:00:0A:EE:AC
inet addr:00.0.00.00 Bcast:00.0.00.00 Mask:255.255.255.000
UP BROADCAST RUNNING NOARP MULTICAST MTU:1430 Metric:1
RX packets:4420 errors:1 dropped:0 overruns:0 frame:0
TX packets:4010 errors:0 dropped:0 overruns:0 carrier:0
collisions:0 txqueuelen:1000
RX bytes:3730453 (3.6 MB) TX bytes:628214 (613.5 KB)

```

The code example above indicates that the interface is already connected and has got an IP address. If you see no output, it indicates that something may be wrong with the modem.

## Check modem status

The “`diagnose sys 5g-modem modem-details`” command enables you to check the modem status. If the modem is working properly with the default configuration and recognized by FortiOS, the following information will show onscreen:

```
FortiWiFi-50G-5G # diagnose sys 5g-modem modem-details
-----
Modem detailed information:
-----
Manufacturer: Telit
Model: FN990A28
IMEI: 0000000000000000
MEID: 0000000000000000
Hardware revision: 1.00
Software revision: M0R.000003-B002
Carrier config: AT&T
Carrier config PRI revision: 3200
Modem temperature: 39 C
Modem operation mode: ONLINE
Modem network mode: 3G|4G|5G
-----
```

Make sure that the modem is set in ONLINE mode. If the modem is in LOW-POWER mode, it will not be able to connect to the network. You can check the settings using the “`config system 5g-modem`” command to make sure that the modem is in ONLINE mode. See [Configure the modem on page 19](#). If the low-power mode issue persists, new modem firmware may need to be flashed.

## Use 5G services

After inspecting the modem and making sure that everything looks fine, insert a micro SIM card in the SIM card slot. The SIM card must be facing down, with the cut corner to the left.

Verify that your SIM card is working before inserting it into the device. For models with two SIM card slots, it does not matter in which slot the SIM card is inserted. With the default configuration, FortiOS constantly scans for available SIM cards and chooses the one with connectivity. The unit will automatically connect to the wireless network and assigns an IP address to its wwan interface:

```
wwan  dhcp  0.0.0.0 0.0.0.0 10.127.198.188 255.255.255.248 up  disable  physical  disable
```

It may take a few minutes for the modem to establish Internet connection because the modem will switch its carrier configuration according to the SIM card used by the carrier, see [execute 5g-modem carrier-config switch <carrier config index> on page 26](#). Once the device is connected, use the “`diagnose test application nr5gd 15`” command to show service information:

```
FortiWiFi-50G-5G # diagnose test application nr5gd 15
temperature = 34,
modem_mode = 5,
system_mode = QMI_GMS_SYSTEM_MODE_NR5G_SA,
ims_reg_state = 4,
ps_state = QMI_GMS_PS_STATE_ATTACHED,
nr5g_info.band = 41,
nr5g_info.bandwidth = QMI_GMS_NR5G_BANDWIDTH_400_MHz,
nr5g_info.rx_chan = 501390,
nr5g_info.tx_chan = 501390,
nr5g_info.rssi = -81,
nr5g_info.rsrp = -91,
nr5g_info.rsrq = -10,
nr5g_info.snr = 175,
nr5g_info.pci = 398,
```

As highlighted above, the system mode shows NR5G\_SA. The 5G protocol parameters indicate that the modem is now connected to a 5G network and is receiving full 5G services.

Additionally, more signal parameters such as SINR, RSRP, and RSRQ are now available for diagnostics purposes.

# Configuration

You can configure the 5G modem in your device in either of the following ways:

- [Configure the modem from FortiGate GUI on page 16](#)
- [Configure the modem from FortiGate Console on page 17](#)

## Configure the modem from FortiGate GUI

1. Set the Ethernet port on your computer to DHCP mode.
2. Use an Ethernet cable to connect your computer to your Fortinet 5G device via any of the Ethernet ports (1 through 3).
3. Start your browser and enter the IP address of your Fortinet 5G device.
4. On the login page, enter the default username 'admin' (case-sensitive), leave the Password field blank (no password), and press *Login*.



By default, your Fortinet 5G device opens to the *Dashboard>Status* page after you log in.

5. Check the status of the modem interface by selecting *Network>Interfaces*, as shown in the following illustration.

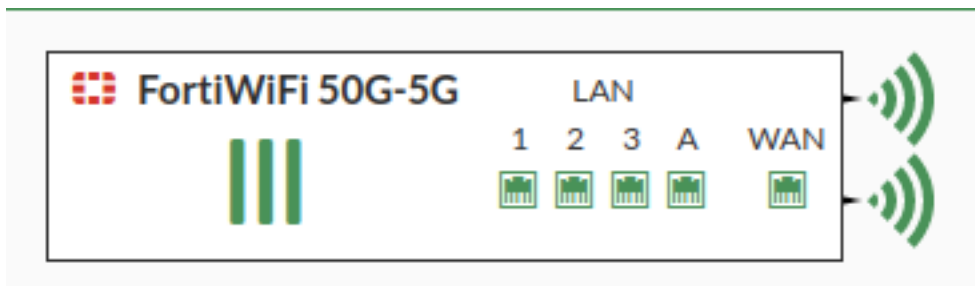

6. In the *Status* column, under *Physical (2)*, make sure that *wwan* which is the 5G network is up (as indicated by a green icon).

Physical Interface 2					
wan	Physical Interface		.220/255.255	PING HTTPS SSH SNMP	
wwan	Physical Interface		188/255.255	PING FMG-Access	

# Configure the modem from FortiGate Console

Configuring the 5G modem from the FortiGate Console requires the following major steps:

1. [Connect your computer to FortiGate on page 17](#)
2. [Create a data plan on page 18](#)
3. [Configure the modem on page 19](#)

## Connect your computer to FortiGate

The following instructions show how to access your Fortinet 5G device from a computer via its console port.

1. Use the serial cable (included in your product package) to connect the serial port of your computer to the console port of your Fortinet 5G device.
2. Start a serial console terminal program from your computer, and set the port to:
  - 9600 baud rate
  - Data bits 8
  - Parity None
  - Stop bits 1
  - Flow control None
3. Press *Enter* on your keyboard to bring up the command line interface (CLI).
4. Type in the default username "admin", enter no password, and press *Enter* on your keyboard to log into the console.
5. Check the network configuration.
6. Use the following commands to check that the firewall policy allows all traffic from the internal ports to flow through the wwan interface:

```
FortiWiFi-50G-5G # show firewall policy
config firewall policy
  edit 1
    set uuid 000bb000-00c0-00ee-0f00-978c89b245a3
    set srcintf "lan"
    set dstintf "wan"
    set action accept
    set srcaddr "all"
    set dstaddr "all"
    set schedule "always"
    set service "ALL"
    set nat enable
  next
  edit 2
    set uuid 000c00b0-00c0-00ee-0000-ff255f95da2a
    set srcintf "lan"
    set dstintf "wwan"
    set action accept
    set srcaddr "all"
```

```

        set dstaddr "all"
        set schedule "always"
        set service "ALL"
        set nat enable
    next
end

```

## Create a data plan

A data-plan contains detailed 5G modem data session settings. Any data connection is initiated using the settings from one of the stored data plans. To make a data connection, you must have at least one data plan defined. Once you have set up a data-plan, you can apply it to the SIM card in use.

```

FortiWiFi-50G-5G # config system 5g-modem
FortiWiFi-50G-5G (5g-modem) # config data-plan
FortiWiFi-50G-5G (data-plan) # edit 1
FortiWiFi-50G-5G (1) # set
apn          Login APN string for PDP-IP packet data calls.
auth-type    Authentication type for PDP-IP packet data calls.
pdp-type     Packet Data Protocol (PDP) context type.
username     Authentication username for PDP-IP packet data calls.
password     Authentication password for PDP-IP packet data calls.

FortiWiFi-50G-5G # config sys 5g-modem

FortiWiFi-50G-5G (5g-modem) # config modem1

FortiWiFi-50G-5G (modem1) # show

FortiWiFi-50G-5G (modem1) # set

sim1-data-plan    data plan for SIM #1.
sim2-data-plan    data plan for SIM #2.

```

You can use the following series of commands to access the wireless profile table on the internal modem:

1. `diag debug enable.`
2. `diag debug app nr5gd -1.`
3. `diag test application nr5gd 14` (for modem1 on FGR-70G-5G-DUAL); `74` (for modem2 on FGR-70G-5G-DUAL).

The following is a sample wireless profile table stored on the internal modem.

```

FortiWiFi-50G-5G # [NR5G_MODEM1]wds_get_profile_list(2466)-1620: Acquired client id 16
[NR5G_MODEM1]wds_get_profile_list(2487)-1620: Found 2 profiles
[NR5G_MODEM1]wds_get_profile_list(2490)-1620: Profile 1:
[NR5G_MODEM1]wds_get_profile_list(2494)-1620:     index: 1
[NR5G_MODEM1]wds_get_profile_list(2495)-1620:     type: 3GPP
[NR5G_MODEM1]wds_get_profile_list(2510)-1620:     Profile name: profile1
[NR5G_MODEM1]wds_get_profile_list(2511)-1620:     pdp_type QMI_WDS_PDP_TYPE_IPV4V6
[NR5G_MODEM1]wds_get_profile_list(2512)-1620:     apn len: 11

```

```

[NR5G_MODEM1]wds_get_profile_list(2513)-1620:    apn: nrbroadband
[NR5G_MODEM1]wds_get_profile_list(2514)-1620:    authentication_pref QMI_WDS_AUTHENTICATION_NONE
[NR5G_MODEM1]wds_get_profile_list(2515)-1620:    username:
[NR5G_MODEM1]wds_get_profile_list(2516)-1620:    password:
[NR5G_MODEM1]wds_get_profile_list(2490)-1620: Profile 2:
[NR5G_MODEM1]wds_get_profile_list(2494)-1620:    index: 4
[NR5G_MODEM1]wds_get_profile_list(2495)-1620:    type: 3GPP
[NR5G_MODEM1]wds_get_profile_list(2510)-1620:    Profile name:
[NR5G_MODEM1]wds_get_profile_list(2511)-1620:    pdp_type QMI_WDS_PDP_TYPE_IPV4V6
[NR5G_MODEM1]wds_get_profile_list(2512)-1620:    apn len: 12
[NR5G_MODEM1]wds_get_profile_list(2513)-1620:    apn: attm2mglobal
[NR5G_MODEM1]wds_get_profile_list(2514)-1620:    authentication_pref QMI_WDS_AUTHENTICATION_NONE
[NR5G_MODEM1]wds_get_profile_list(2515)-1620:    username:
[NR5G_MODEM1]wds_get_profile_list(2516)-1620:    password:

```

The above is the wireless profile of a modem with the AT&T firmware. If the APN is left empty, it indicates that it's a wildcard entry; if the username is empty, it means that no authentication has been configured.

## Configure the modem

This section introduces the commands for configuring the built-in 5G modem.

You can start configuring the modem using the "config system 5g-modem" command, and then use the "set" command to configure the various parameters:

```

FortiWiFi-50G-5G # config sys 5g-modem

FortiWiFi-50G-5G (5g-modem) # config modem1

FortiWiFi-50G-5G (modem1) # set
status          Enable/disable Modem online mode.
network-type    Modem network type.
sim1-pin        PIN code for SIM #1 (if applicable).
sim2-pin        PIN code for SIM #2 (if applicable).
sim1-data-plan  data plan for SIM #1.
sim2-data-plan  data plan for SIM #2.
carrier-config  carrier-config selection mode.
gps-service     Enable/disable Modem online mode.

```

Click the following links to see how to use each of the commands:

- [set status on page 20](#)
- [set network-type on page 20](#)
- [set sim1-pin/sim2-pin on page 22](#)
- [set sim1-data-plan/sim2-data-plan on page 23](#)
- [set carrier-config on page 23](#)
- [set gps-service on page 24](#)

## set status

The command allows you to enable or disable the modem. It acts as the switch of the 5G modem daemon. When the 5G modem daemon is switched off, the modem stops transferring data, but you can still use the AT command interface. It is important to note that disabling the 5G modem daemon does not disable the GPS and data usage tracking daemons. It does not affect the DM port, either.

```
FortiWiFi-50G-5G (modem1) # set status
disable    Disable modem to low power mode(no RF signal).
enable     Enable modem to Online mode.
```

## set network-type

The command lets you set the network type.

```
FortiWiFi-50G-5G (modem1) # set network-type
auto       Automatic detection
4g|5g      connect to 4G and 5G network only. Applies to 5G Non-Standalone (NSA) networks.
3g|4g      connect to 3G and 4G network only.
3g|5g      connect to 3G and 5G network only.
5g         connect to 5G network only, for networks use MIMO/mm waves technology. Applies to 5G
Standalone(SA) networks.
4g         connect to 4G network only, for networks use LTE technology.
3g         connect to 3G network only, for networks use WCDMA technology
```



A warning message prints out onscreen when you set "network-type" to "5g" only.

```
FortiWiFi-50G-5G (modem1) # set network-type 5g
Warning: Setting network_type to '5g' only may result in network loss in areas don't support 5G
Standalone(SA) deployment.
Consider using '4g|5g' for area only support 5G Non-Standalone(NSA) deployment.
```

By default, "network-type" is set to "auto". This allows the modem to automatically connect to the 5G network when it's available and fall back to the LTE modem when 5G signal is lost. The modem is designed to hand over back to the 5G network when the signal comes back.

## Standalone Network/Non-Standalone Network

A standalone (SA) network only utilizes the 5G bands and do not use the LTE bands anymore. A non-standalone (NSA) network, on the other hand, utilizes the LTE technology as the foundation and boosts network speed by utilizing the 5G bands when needed. For instance, T-Mobile supports SA mode, which means it can be used via 5g-only network type. AT&T and Verizon support NSA mode, which means it can be used when "network-type" is set to "auto" or "4g|5g".

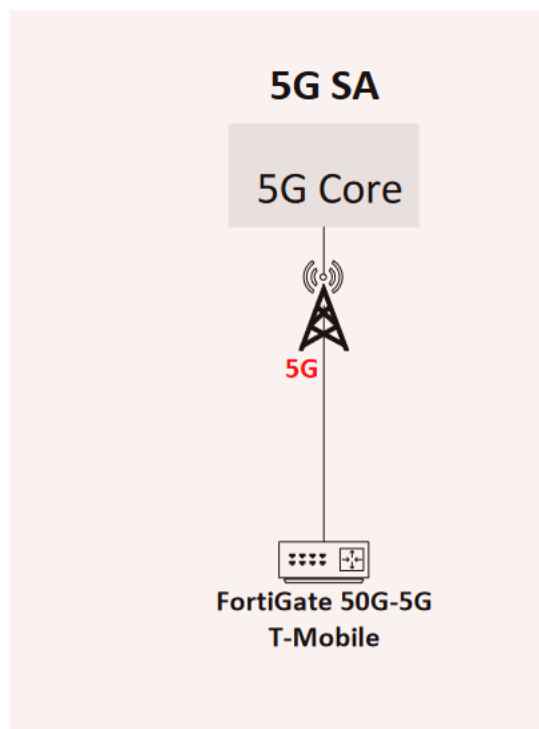
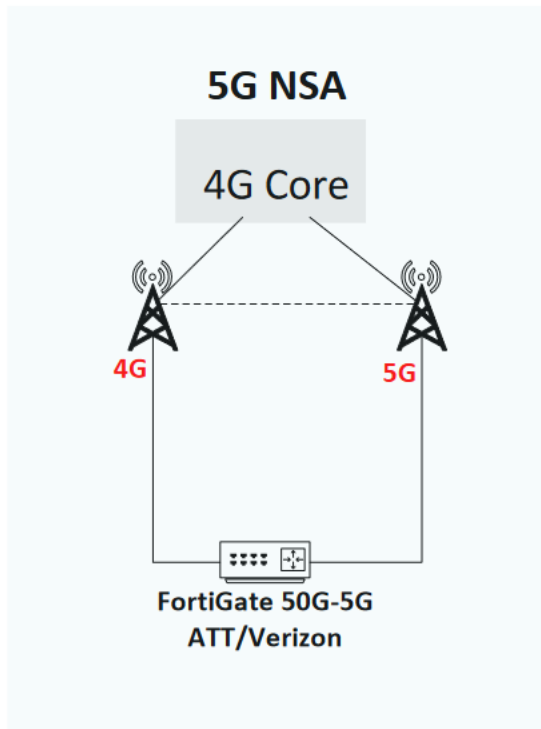

## Event log for modem network-type switch

```
LOG_ID_INTERNAL_5G_MODEM1_SIGNAL_NONE = 46720,
LOG_ID_INTERNAL_5G_MODEM1_SIGNAL_3G4G = 46721,
LOG_ID_INTERNAL_5G_MODEM1_SIGNAL_5G = 46722,
```

```
LOG_ID_INTERNAL_5G_MODEM2_SIGNAL_NONE = 46820,
LOG_ID_INTERNAL_5G_MODEM2_SIGNAL_3G4G = 46821,
LOG_ID_INTERNAL_5G_MODEM2_SIGNAL_5G = 46822,
```

modem1:

>>> when no signal, it shows log as below

```
2: date=2024-01-24 time=11:28:47 eventtime=1706124527270807347 tz="-0800" logid="0100046720"
type="event" subtype="system" level="information" vd="root" logdesc="5G modem1 has no 3G/4G/5G
signal." msg="The modem1 can not find the signal."
```

>>> when plug in Verizon/ATT sim card which is support NSA, get 3g4g signal, 5G LED amber, it shows log as below:

```
27: date=2024-01-24 time=11:39:33 eventtime=1706125174022709964 tz="-0800" logid="0100046721"
type="event" subtype="system" level="information" vd="root" logdesc="5G modem1 signal mode is
3G/4G." msg="The modem1 is on 3G/4G QMI_GMS_SYSTEM_MODE_LTE mode."
```

>>> After run speed test, Verizon/ATT speed up to 5G, get 5G signal, 5G LED green it shows log as below:

```
24: date=2024-01-24 time=11:49:55 eventtime=1706125794982786673 tz="-0800" logid="0100046722"
type="event" subtype="system" level="information" vd="root" logdesc="5G modem1 signal mode is 5G."
msg="The modem1 is on 5G QMI_GMS_SYSTEM_MODE_NR5G_NSA mode."
```

>>> when plug in T mobile sim card which is support SA, get 5G signal, 5G LED green it shows log as below:

```
27: date=2024-01-24 time=12:06:20 eventtime=1706126780742448259 tz="-0800" logid="0100046722"
type="event" subtype="system" level="information" vd="root" logdesc="5G modem1 signal mode is 5G."
msg="The modem1 is on 5G QMI_GMS_SYSTEM_MODE_NR5G_SA mode."
```

modem2:

>>> when no signal, it shows log as below

```
10: date=2024-01-24 time=12:09:16 eventtime=1706126955910048511 tz="-0800" logid="0100046820"
type="event" subtype="system" level="information" vd="root" logdesc="5G modem2 has no 3G/4G/5G
signal." msg="The modem2 can not find the signal."
```

>>> when plug in Verizon/ATT sim card which is support NSA, get 3g4g signal, 5G LED amber, it shows log as below:

```
27: date=2024-01-24 time=12:13:17 eventtime=1706127198054485154 tz="-0800" logid="0100046821"
type="event" subtype="system" level="information" vd="root" logdesc="5G modem2 signal mode is
3G/4G." msg="The modem2 is on 3G/4G QMI_GMS_SYSTEM_MODE_LTE signal mode."
```

>>> After run speed test, Verizon/ATT speed up to 5G, get 5G signal, 5G LED green, it shows log as below:

```
3: date=2024-01-24 time=12:16:11 eventtime=1706127371238313718 tz="-0800" logid="0100046822"
type="event" subtype="system" level="information" vd="root" logdesc="5G modem2 signal mode is 5G."
msg="The modem2 is on 5G QMI_GMS_SYSTEM_MODE_NR5G_NSA signal mode."
```

>>> when plug in T mobile sim card which is support SA, get 5G signal, 5G LED green it shows log as below:

```
32: date=2024-01-24 time=12:20:05 eventtime=1706127605382191187 tz="-0800" logid="0100046822"
type="event" subtype="system" level="information" vd="root" logdesc="5G modem2 signal mode is 5G."
msg="The modem2 is on 5G QMI_GMS_SYSTEM_MODE_NR5G_SA signal mode."
```

## set sim1-pin/sim2-pin

The commands set the pins for the inserted SIM cards.

```
FortiGate-50G-5G (modem1) # set sim1-pin
<passwd> please input password value
```

```
FortiGate-50G-5G (modem1) # set sim2-pin
<passwd> please input password value
```

## set sim1-data-plan/sim2-data-plan

This command enables you to apply the corresponding data-plan profiles to the inserted SIM card.

```
FortiGate-50G-5G (modem1) # set sim1-data-plan
<string>    please input string value

FortiGate-50G-5G (modem1) # set sim2-data-plan
<string>    please input string value
```

## set carrier-config

This command enables you to choose the corresponding carrier-configuration file to pair with the inserted SIM card. With the manual option, once it is set up, you can run the "execute 5g-modem carrier-config list" command to get the carrier list, from which you can choose the corresponding carrier to pair with the inserted SIM card.

```
FortiWiFi-50G-5G (modem1) # set carrier-config
auto-gcf      Auto select carrier-config by SIM. When unrecognized SIM, use Generic GCF(World).
auto-ptcrb    Auto select carrier-config by SIM. When unrecognized SIM, use Generic PTCRB(North
America).
manual        Manual select carrier-config by execute 5g-modem carrier-config switch command.
```

For carriers that are not listed in the list, you can use a "Generic" option instead.

```
FortiWiFi-50G-5G # execute 5g-modem carrier-config list
-----
Available carrier config:
0:Generic GCF
1:Generic PTCRB
10:AT&T
11:T-Mobile
12:Verizon
14:Bell
15:Rogers
16:Telus
20:SK Telecom
21:SK Telecom Dongle
22:KT
30:NTT Docomo
31:KDDI
40:Telstra
50:LATAM
60:Telefonica
61:DTAG
-----

FortiWiFi-50G-5G # execute 5g-modem carrier-config switch
<carrier config index>    carrier config index to switch to.
```

## set gps-service

The command lets you to enable or disable GPS service on the modem.

If you have a FortiGate 50G device that comes with a GPS antenna, you can enable this option to get accurate location information when GPS signal is good.

```
FortiWiFi-50G-5G (modem1) # set gps-service
enable      Enable GPS service.
disable     Disable GPS service.
```

# Execute 5g-modem commands

You can use the "execute 5g-modem" command to manage the 5G device modem.

```
FortiWiFi-50G-5G # execute 5g-modem
carrier-config      carrier-config
cold-reboot         Cold reboot 5G Modem.
firmware-upgrade    firmware-upgrade
reboot              Warm reboot 5G Modem.
sim-switch          Perform SIM switch for modem.
```

There is no "sim-switch" option on FGR-5G-D devices, as shown in the following sample code:



```
FortiGateRugged-FGR-5G-D # execute 5g-modem
carrier-config      carrier-config
cold-reboot         Cold reboot 5G Modem.
firmware-upgrade    firmware-upgrade
reboot              Warm reboot 5G Modem.
```

- [execute 5g-modem carrier-config](#) on page 25
- [execute 5g-modem carrier-config switch <carrier config index>](#) on page 26
- [execute 5g-modem cold-reboot](#) on page 26
- [execute 5g-modem reboot](#) on page 27
- [execute 5g-modem sim-switch](#) on page 27



For firmware upgrade, visit [Manual firmware upgrade](#) or [Scheduled auto firmware upgrade from FortiGuard](#).

## execute 5g-modem carrier-config

Show the index of available carrier configurations.

```
FortiWiFi-50G-5G # exe 5g-modem carrier-config
-----
Available carrier config:
0:Generic GCF
1:Generic PTCRB
10:AT&T
11:T-Mobile
```

```
12:Verizon
14:Bell
15:Rogers
16:Telus
20:SK Telecom
21:SK Telecom Dongle
22:KT
30:NTT Docomo
31:KDDI
40:Telstra
50:LATAM
60:Telefonica
61:DTAG
-----
```

## execute 5g-modem carrier-config switch <carrier config index>

Switch to the carrier config index according to the SIM card in use.

```
FortiWiFi-50G-5G # exe 5g-modem carrier-config switch
<carrier config index> carrier config index to switch to.
```

```
FortiWiFi-50G-5G # execute 5g-modem carrier-config switch 10

Modem1 carrier config switched, modem will reboot now.
```

## execute 5g-modem cold-reboot

Power off the internal 5G modem for one second and then power it back on.

```
FortiWiFi-50G-5G # exe 5g-modem cold-reboot
Modem cold reboot done.
```



On FGR-5G-D devices, there is an option that allows you to choose which modem to cold-reboot, as illustrated in the following code example:

```
FortiGateRugged-FGR-5G-D # execute 5g-modem cold-reboot
< 1 | 2 | all> modem entry.
```

---

## execute 5g-modem reboot

Warm-reboot the internal 5G modem.

```
FortiWiFi-50G-5G # exe 5g-modem reboot
Modem reboot successfully.
```



On FGR-5G-D devices, there is an option that lets you choose which modem to reboot, as illustrated in the following code example:

```
FortiGateRugged-FGR-5G-D # execute 5g-modem reboot
< 1 | 2 | all> modem entry.
```

## execute 5g-modem sim-switch

Switch between SIM1 and SIM2.

```
FortiWiFi-50G-5G # diagnose sys 5g-modem sim-info
-----
Active Slot: SLOT-2
-----
SLOT-1 status:SIM_CARD_PRESENT
SLOT-1 ICCID:000000000000000000
-----
SLOT-2 status:SIM_CARD_PRESENT
SLOT-2 ICCID:000000000000000000
SLOT-2 IMSI:0000000000000000
SLOT-2 Country:United States
SLOT-2 Network:AT&T
SLOT-2 PIN status:Ready
-----
FortiWiFi-50G-5G # exe 5g-modem sim-switch
Modem SIM switch done.

FortiWiFi-50G-5G # dia sys 5g-modem sim-info
-----
Active Slot: SLOT-1
-----
SLOT-1 status:SIM_CARD_PRESENT
SLOT-1 ICCID:000000000000000000
SLOT-1 IMSI:0000000000000000
SLOT-1 Country:United States
SLOT-1 Network:AT&T
SLOT-1 PIN status:Ready
-----
```

```
SLOT-2 status:SIM_CARD_PRESENT  
SLOT-2 ICCID:00000000000000000000  
-----
```



On FGR-5G-D devices, both SIM1 and SIM2 are active at the same time; no sim-switch option is available.

---

# Diagnose system commands

You can use the "diagnose sys 5g-modem" command to check the various information of the 5G modem.

```
FortiWiFi-50G-5G # diagnose sys 5g-modem ?
modem-details      5G Modem detailed information
sim-info           5G Modem SIM card information
signal-info        5G Modem signal information
data-session-info  5G Modem data session information
traffic-status     5G Modem traffic status
gps-info           5G Modem GPS information
```



On FGR-5G-D devices, the "diagnose sys 5g-modem" command provides options for you to choose the modem whose information you want to display, as shown in the following example.

```
FortiGateRugged-FGR-5G-D # diagnose sys 5g-modem xxxx < 1 | 2 | all> Show
details of modem entry.
```

- [diagnose sys 5g-modem modem-details on page 29](#)
- [diagnose sys 5g-modem sim-info on page 30](#)
- [diagnose sys 5g-modem signal-info on page 30](#)
- [diagnose sys 5g-modem data-session-info on page 31](#)
- [diagnose sys 5g-modem traffic-status on page 32](#)
- [diagnose sys 5g-modem gps-info on page 32](#)

## diagnose sys 5g-modem modem-details

Show detailed information of the modem.

```
FortiWiFi-50G-5G # diagnose sys 5g-modem modem-details
-----
Modem detailed information:
-----
Manufacturer: Telit
Model: FN990A28
IMEI: 0000000000000000
MEID: 0000000000000000
Hardware revision: 1.00
Software revision: M0R.000003
Carrier config: T-Mobile
Carrier config PRI revision: 9012
Modem temperature: 39 C
```

```
Modem operation mode: ONLINE
Modem network mode: 4G|5G
-----
```

## diagnose sys 5g-modem sim-info

Show modem SIM information.

```
FortiWiFi-50G-5G # diagnose sys 5g-modem sim-info
-----
SIM information:
-----
Active Slot: SLOT-1
-----
SLOT-1 status:SIM_CARD_PRESENT
SLOT-1 ICCID:000000000000000000
SLOT-1 MSISDN: 0000000000
SLOT-1 IMSI:0000000000000000
SLOT-1 Country:United States
SLOT-1 Network:T-Mobile
SLOT-1 PIN status:Ready
-----
SLOT-2 status:ABSENT
SLOT-2 ICCID:
-----
```

There are three SIM card detection states:

- QMI\_UIM\_CARD\_STATE\_PRESENT
- QMI\_UIM\_CARD\_STATE\_ABSENT
- QMI\_UIM\_CARD\_STATE\_ERROR

The first two states are quite obvious, but the third state usually indicates that the modem has trouble recognizing the inserted SIM card.

## diagnose sys 5g-modem signal-info

Show modem signal information.

```
FortiWiFi-50G-5G # diagnose sys 5g-modem signal-info
-----
Signal information:
-----
LTE RSSI -66(GOOD_SIGNAL)
LTE RSRQ -15
```

```
LTE RSRP -94(FAIR_TO_POOR_SIGNAL)
LTE SNR 96(FAIR_TO_POOR_SIGNAL)
-----
NR5G RSRP -81(GOOD_SIGNAL)
NR5G SNR 230(EXCELLENT_SIGNAL)
-----
```

## diagnose sys 5g-modem data-session-info

Show data session information.

```
FortiWiFi-50G-5G # diagnose sys 5g-modem data-session-info
-----
Data session information:
-----
IPV4 connection: QMI_WDS_CONNECTION_STATUS_CONNECTED
Profile index: 3
Profile name: ftnt_custom
Profile PDP type: QMI_WDS_PDP_TYPE_IPV4V6
Profile APN name: broadband
IPV4 IP: 00.000.00.000
IPV4 gateway: 00.000.00.000
IPV4 netmask: 255.255.255.000
IPV4 primary DNS: 00.000.0.00
IPV4 secondary DNS: 00.000.0.000
MTU: 1440
-----
```

Parameter	Description
<i>IPV4 connection</i>	The status of the connection.
<i>Profile index</i>	The wireless profile used in the current data session.
<i>Profile name</i>	Wireless profile name.
<i>Profile PDP type</i>	The PDP types allowed by the wireless profile.
<i>Profile APN name</i>	Wireless profile APN name.
<i>IPV4 IP</i>	The IPv4 IP address. <b>Note:</b> IP addresses are always acquired through DHCP although some SIM cards offer static IPs.
<i>IPV4 gateway</i>	IPv4 gateway address.
<i>IPV4 netmask</i>	IPv4 netmask IP.
<i>IPV4 primary DNS</i>	IPv4 primary DNS address.

Parameter	Description
<i>IPV4 secondary DNS</i>	IPv4 secondary DNS address.
<i>MTU</i>	The MTU on the wireless front end. <b>Note:</b> The MTU on the Ethernet interface <code>wan</code> can be different. If the <code>wan</code> runs the link protocol RAW IP, the MTU on the Ethernet interface must be changed to the same as the one used on the wireless front end. Otherwise, it will not work.

## diagnose sys 5g-modem traffic-status

Show the modem traffic status. The statistics will reset to 0 when the wireless network type changes, such as falling back from 5G to LTE network or vice versa, or when the data session is disconnected.

```
FortiWiFi-50G-5G # diagnose sys 5g-modem traffic-status
```

```
-----  
traffic information:
```

```
-----
```

```
IPV4 TX packets OK: 553  
IPV4 RX packets OK: 517  
IPV4 TX packets error: 0  
IPV4 RX packets error: 0  
IPV4 TX overflows: 0  
IPV4 RX overflows: 0  
IPV4 TX bytes OK: 46881  
IPV4 RX bytes OK: 55666  
IPV4 TX packets dropped: 0  
IPV4 RX packets dropped: 0
```

```
-----
```

```
IPV6 TX packets OK: 0  
IPV6 RX packets OK: 0  
IPV6 TX packets error: 0  
IPV6 RX packets error: 0  
IPV6 TX overflows: 0  
IPV6 RX overflows: 0  
IPV6 TX bytes OK: 0  
IPV6 RX bytes OK: 0  
IPV6 TX packets dropped: 0  
IPV6 RX packets dropped: 0
```

```
-----
```

## diagnose sys 5g-modem gps-info

Show the modem GPS information.

```
FortiWiFi-50G-5G # diagnose sys 5g-modem gps-info
-----
GPS information:
-----
Modem1 searching for GPS
-----
FortiWiFi-50G-5G # diagnose sys 5g-modem gps-info
-----
GPS information:
-----
Latitude: 37.376258
Longitude: -122.011015
UTC time: Fri Dec 8 00:39:20 2023
Local time: Thu Dec 7 16:39:20 2023
-----
```



On a device equipped with a GPS antenna, if the location information is retrieved, the latitude, longitude, and UTC Time are also displayed.

---

# Diagnose test application commands

Use the "diagnose test application nr5gd 0" command to view all diagnose test application commands.

```
FortiWiFi-50G-5G # diagnose test application nr5gd 0
```

- 1: Show modem1 state machine status.
- 2: Show modem1 operation mode.
- 3: Show modem1 connection state
- 4: Show modem1 next scheduled dial time.
- 5: Show modem1 fw upgrade port.
- 6: Show modem1 slot info.
- 7: Show modem1 1st at port.
- 8: Show modem1 2nd at port.
- 9: Show modem1 QMI port.
- 10: Show modem1 AT#SIMINCFG? result.
- 11: Show modem1 AT#5GLINKSTAT? result.
- 12: Show modem1 GPS power status.
- 13: Show modem1 GPS location.
- 14: Show modem1 wireless profile list in debug info.
- 15: Show modem1 signal and band status.
- 16: Show modem1 outbound source-ip check status.
- 22: Test modem1 warm reboot.
- 23: Test modem1 power on GPIO.
- 24: Test modem1 power off GPIO.
- 25: Test modem1 stop network then reconnect.
- 26: Test modem1 sim switch.
- 27: Test modem1 clean up custom wireless profile.
- 28: Test modem1 reboot current active SIM module.
- 29: Test modem1 reset.
- 30: Test modem1 power supply on.

For FGR-5G-D devices, there are some different or additional diagnostic test command options, as shown in the following code example:

```
FortiWiFi-50G-5G # diagnose test application nr5gd 0
```

```
1: Show modem1 state machine status.
2: Show modem1 operation mode.
3: Show modem1 connection state
4: Show modem1 next scheduled dial time.
5: Show modem1 fw upgrade port.
6: Show modem1 slot info.
7: Show modem1 1st at port.
8: Show modem1 2nd at port.
9: Show modem1 QMI port.
10: Show modem1 AT#SIMINCFG? result.
11: Show modem1 AT#5GLINKSTAT? result.
12: Show modem1 GPS power status.
13: Show modem1 GPS location.
14: Show modem1 wireless profile list in debug info.
15: Show modem1 signal and band status.
16: Show modem1 outbound source-ip check status.
22: Test modem1 warm reboot.
23: Test modem1 power on GPIO.
24: Test modem1 power off GPIO.
25: Test modem1 stop network then reconnect.
26: Test modem1 sim switch.
27: Test modem1 clean up custom wireless profile.
28: Test modem1 reboot current active SIM module.
29: Test modem1 reset.
30: Test modem1 power supply on.
```



```
-----
61: Show state machine status.
62: Show modem2 operation mode.
63: Show modem2 connection state
64: Show modem2 next scheduled dail time.
65: Show modem2 fw upgrade port.
66: Show modem2 slot info.
67: Show modem2 1st at port.
68: Show modem2 2nd at port.
69: Show modem2 QMI port.
70: Show modem2 AT#SIMINCFG? result.
71: Show modem2 AT#5GLINKSTAT? result.
72: Show modem2 GPS power status.
73: Show modem2 GPS location.
74: Show modem2 wireless profile list in debug info.
75: Show modem2 signal and band status.
```

80: clear debug filter.  
81: set debug filter to NR5G\_MODEM2 only.  
82: Test modem2 warm reboot.  
83: Test modem2 power on GPIO.  
84: Test modem2 power off GPIO.  
85: Test modem2 stop network then reconnect.  
87: Test modem2 clean up custom wireless profile.  
88: Test modem2 reboot current active SIM module.  
89: Test modem2 reset.  
90: Test modem2 power supply on.

---

- [diagnose test application nr5gd 1 on page 36](#)
- [diagnose test application nr5gd 2 on page 37](#)
- [diagnose test application nr5gd 3 on page 37](#)
- [diagnose test application nr5gd 4 on page 37](#)
- [diagnose test application nr5gd 5 on page 37](#)
- [diagnose test application nr5gd 6 on page 38](#)
- [diagnose test application nr5gd 7 on page 38](#)
- [diagnose test application nr5gd 8 on page 38](#)
- [diagnose test application nr5gd 9 on page 38](#)
- [diagnose test application nr5gd 10 on page 39](#)
- [diagnose test application nr5gd 11 on page 39](#)
- [diagnose test application nr5gd 12 on page 39](#)
- [diagnose test application nr5gd 13 on page 39](#)
- [diagnose test application nr5gd 14 on page 40](#)
- [diagnose test application nr5gd 15 on page 42](#)
- [diagnose test application nr5gd 22 on page 42](#)
- [diagnose test application nr5gd 23 on page 42](#)
- [diagnose test application nr5gd 24 on page 42](#)
- [diagnose test application nr5gd 25 on page 43](#)
- [diagnose test application nr5gd 26 on page 43](#)
- [diagnose test application nr5gd 27 on page 44](#)
- [diagnose test application nr5gd 28 on page 44](#)
- [diagnose test application nr5gd 29 on page 45](#)
- [diagnose test application nr5gd 30 on page 45](#)

## diagnose test application nr5gd 1

Show modem1 current state.

```
FortiWiFi-50G-5G # diagnose test application nr5gd 1
Modem 1 current state:ST_MODEM_CONNECTED
```

## diagnose test application nr5gd 2

Show modem 1 current mode.

```
FortiWiFi-50G-5G # diagnose test application nr5gd 2
Modem1 current mode: ONLINE
```

## diagnose test application nr5gd 3

Show modem1 connection status.

```
FortiWiFi-50G-5G # diagnose test application nr5gd 3
Modem1 connection status:1
```

## diagnose test application nr5gd 4

Show modem1 next scheduled dial time.

```
FortiWiFi-50G-5G # diagnose test application nr5gd 4
There's no scheduled next dial time.
```

## diagnose test application nr5gd 5

Show modem1 firmware upgrade port.

```
FortiWiFi-50G-5G # diagnose test application nr5gd 5
modem1 fw upgrade port:/dev/ttyusb0
nCf debug_zone->modem1_fw_port:/dev/ttyusb0
```

## diagnose test application nr5gd 6

Show modem1 slot information.

```
FortiWiFi-50G-5G # diagnose test application nr5gd 6
Modem1 sim1 state:SIM_CARD_PRESENT, iccid:00000000000000000000
Modem1 sim2 state:ABSENT, iccid:
```

## diagnose test application nr5gd 7

Show modem1 1st AT port.

```
FortiWiFi-50G-5G # diagnose test application nr5gd 7
modem1 at port:/dev/ttyusb2
```



You can retrieve modem2 1st AT port on FGR-70G-5G-DUAL using the following command:

```
diagnose test application nr5gd 67
1st AT port: diagnose test application nrg5d 67
```

---

## diagnose test application nr5gd 8

Show modem1 2nd AT port.

```
FortiWiFi-50G-5G # diagnose test application nr5gd 8
modem1 2nd at port:/dev/ttyusb3
```



You can retrieve modem2 2nd AT port on FGR-70G-5G-DUAL using the following command:

```
diagnose test application nr5gd 68
2nd AT port: diagnose test application nrg5d 68
```

---

## diagnose test application nr5gd 9

Show modem1 QMI port.

```
FortiWiFi-50G-5G # diagnose test application nr5gd 9
modem1 QMI port:/dev/cdc-wdm0
modem1 QMI interface:wwan
```

## diagnose test application nr5gd 10

Show modem1 AT#SIMINCFG? result.

```
FortiWiFi-50G-5G # diagnose test application nr5gd 10
AT#SIMINCFG?
#SIMINCFG: 1,0
#SIMINCFG: 2,0
OK
```

## diagnose test application nr5gd 11

Show modem1 AT#5GLINKSTAT? result.

```
FortiWiFi-50G-5G # diagnose test application nr5gd 11
AT#5GLINKSTAT?
#5GLINKSTAT: 0,1,1
OK
```

## diagnose test application nr5gd 12

Show modem1 GPS power status.

```
FortiWiFi-50G-5G # diagnose test application nr5gd 12
GPS power status:1
```

## diagnose test application nr5gd 13

Show modem1 GPS location.

```
FortiWiFi-50G-5G # diagnose test application nr5gd 13
Latitude: 37.376377, Longitude: -122.011029
```

## diagnose test application nr5gd 14

Show modem1 wireless profile list in debug information.



You must use the "diagnose debug enable" command to enable debug mode, and then run "diagnose dedug application nr5gd -1" command to show the list of wireless profiles.

```
FortiWiFi-50G-5G # diagnose test application nr5gd 14
[NR5G_MODEM1]wds_get_profile_list(2575)-1599: Acquired client id 16
[NR5G_MODEM1]wds_get_profile_list(2596)-1599: Found 8 profiles
[NR5G_MODEM1]wds_get_profile_list(2599)-1599: Profile 1:
[NR5G_MODEM1]wds_get_profile_list(2603)-1599:     index: 1
[NR5G_MODEM1]wds_get_profile_list(2604)-1599:     type: 3GPP
[NR5G_MODEM1]wds_get_profile_list(2619)-1599:     Profile name:
[NR5G_MODEM1]wds_get_profile_list(2620)-1599:     pdp_type QMI_WDS_PDP_TYPE_IPV4V6
[NR5G_MODEM1]wds_get_profile_list(2621)-1599:     apn len: 3
[NR5G_MODEM1]wds_get_profile_list(2622)-1599:     apn: ims
[NR5G_MODEM1]wds_get_profile_list(2623)-1599:     authentication_pref QMI_WDS_AUTHENTICATION_NONE
[NR5G_MODEM1]wds_get_profile_list(2624)-1599:     username:
[NR5G_MODEM1]wds_get_profile_list(2625)-1599:     password:
[NR5G_MODEM1]wds_get_profile_list(2599)-1599: Profile 2:
[NR5G_MODEM1]wds_get_profile_list(2603)-1599:     index: 2
[NR5G_MODEM1]wds_get_profile_list(2604)-1599:     type: 3GPP
[NR5G_MODEM1]wds_get_profile_list(2619)-1599:     Profile name:
[NR5G_MODEM1]wds_get_profile_list(2620)-1599:     pdp_type QMI_WDS_PDP_TYPE_IPV4V6
[NR5G_MODEM1]wds_get_profile_list(2621)-1599:     apn len: 8
[NR5G_MODEM1]wds_get_profile_list(2622)-1599:     apn: vzwadmin
[NR5G_MODEM1]wds_get_profile_list(2623)-1599:     authentication_pref QMI_WDS_AUTHENTICATION_NONE
[NR5G_MODEM1]wds_get_profile_list(2624)-1599:     username:
[NR5G_MODEM1]wds_get_profile_list(2625)-1599:     password:
[NR5G_MODEM1]wds_get_profile_list(2599)-1599: Profile 3:
[NR5G_MODEM1]wds_get_profile_list(2603)-1599:     index: 3
[NR5G_MODEM1]wds_get_profile_list(2604)-1599:     type: 3GPP
[NR5G_MODEM1]wds_get_profile_list(2619)-1599:     Profile name:
[NR5G_MODEM1]wds_get_profile_list(2620)-1599:     pdp_type QMI_WDS_PDP_TYPE_IPV4V6
[NR5G_MODEM1]wds_get_profile_list(2621)-1599:     apn len: 11
[NR5G_MODEM1]wds_get_profile_list(2622)-1599:     apn: vzwinternet
[NR5G_MODEM1]wds_get_profile_list(2623)-1599:     authentication_pref QMI_WDS_AUTHENTICATION_NONE
[NR5G_MODEM1]wds_get_profile_list(2624)-1599:     username:
[NR5G_MODEM1]wds_get_profile_list(2625)-1599:     password:
[NR5G_MODEM1]wds_get_profile_list(2599)-1599: Profile 4:
[NR5G_MODEM1]wds_get_profile_list(2603)-1599:     index: 4
[NR5G_MODEM1]wds_get_profile_list(2604)-1599:     type: 3GPP
```

```

[NR5G_MODEM1]wds_get_profile_list(2619)-1599: Profile name:
[NR5G_MODEM1]wds_get_profile_list(2620)-1599: pdp_type QMI_WDS_PDP_TYPE_IPV4V6
[NR5G_MODEM1]wds_get_profile_list(2621)-1599: apn len: 6
[NR5G_MODEM1]wds_get_profile_list(2622)-1599: apn: vzwapp
[NR5G_MODEM1]wds_get_profile_list(2623)-1599: authentication_pref QMI_WDS_AUTHENTICATION_NONE
[NR5G_MODEM1]wds_get_profile_list(2624)-1599: username:
[NR5G_MODEM1]wds_get_profile_list(2625)-1599: password:
[NR5G_MODEM1]wds_get_profile_list(2599)-1599: Profile 5:
[NR5G_MODEM1]wds_get_profile_list(2603)-1599: index: 5
[NR5G_MODEM1]wds_get_profile_list(2604)-1599: type: 3GPP
[NR5G_MODEM1]wds_get_profile_list(2619)-1599: Profile name:
[NR5G_MODEM1]wds_get_profile_list(2620)-1599: pdp_type QMI_WDS_PDP_TYPE_IPV4V6
[NR5G_MODEM1]wds_get_profile_list(2621)-1599: apn len: 0
[NR5G_MODEM1]wds_get_profile_list(2622)-1599: apn:
[NR5G_MODEM1]wds_get_profile_list(2623)-1599: authentication_pref QMI_WDS_AUTHENTICATION_NONE
[NR5G_MODEM1]wds_get_profile_list(2624)-1599: username:
[NR5G_MODEM1]wds_get_profile_list(2625)-1599: password:
[NR5G_MODEM1]wds_get_profile_list(2599)-1599: Profile 6:
[NR5G_MODEM1]wds_get_profile_list(2603)-1599: index: 6
[NR5G_MODEM1]wds_get_profile_list(2604)-1599: type: 3GPP
[NR5G_MODEM1]wds_get_profile_list(2619)-1599: Profile name:
[NR5G_MODEM1]wds_get_profile_list(2620)-1599: pdp_type QMI_WDS_PDP_TYPE_IPV4V6
[NR5G_MODEM1]wds_get_profile_list(2621)-1599: apn len: 9
[NR5G_MODEM1]wds_get_profile_list(2622)-1599: apn: vzwclass6
[NR5G_MODEM1]wds_get_profile_list(2623)-1599: authentication_pref QMI_WDS_AUTHENTICATION_NONE
[NR5G_MODEM1]wds_get_profile_list(2624)-1599: username:
[NR5G_MODEM1]wds_get_profile_list(2625)-1599: password:
[NR5G_MODEM1]wds_get_profile_list(2599)-1599: Profile 7:
[NR5G_MODEM1]wds_get_profile_list(2603)-1599: index: 7
[NR5G_MODEM1]wds_get_profile_list(2604)-1599: type: 3GPP
[NR5G_MODEM1]wds_get_profile_list(2619)-1599: Profile name:
[NR5G_MODEM1]wds_get_profile_list(2620)-1599: pdp_type QMI_WDS_PDP_TYPE_IPV4V6
[NR5G_MODEM1]wds_get_profile_list(2621)-1599: apn len: 9
[NR5G_MODEM1]wds_get_profile_list(2622)-1599: apn: vzwclass7
[NR5G_MODEM1]wds_get_profile_list(2623)-1599: authentication_pref QMI_WDS_AUTHENTICATION_NONE
[NR5G_MODEM1]wds_get_profile_list(2624)-1599: username:
[NR5G_MODEM1]wds_get_profile_list(2625)-1599: password:
[NR5G_MODEM1]wds_get_profile_list(2599)-1599: Profile 8:
[NR5G_MODEM1]wds_get_profile_list(2603)-1599: index: 8
[NR5G_MODEM1]wds_get_profile_list(2604)-1599: type: 3GPP
[NR5G_MODEM1]wds_get_profile_list(2619)-1599: Profile name: ftnt_custom
[NR5G_MODEM1]wds_get_profile_list(2620)-1599: pdp_type QMI_WDS_PDP_TYPE_IPV4V6
[NR5G_MODEM1]wds_get_profile_list(2621)-1599: apn len: 14
[NR5G_MODEM1]wds_get_profile_list(2622)-1599: apn: we01.vzwstatic
[NR5G_MODEM1]wds_get_profile_list(2623)-1599: authentication_pref QMI_WDS_AUTHENTICATION_NONE
[NR5G_MODEM1]wds_get_profile_list(2624)-1599: username:
[NR5G_MODEM1]wds_get_profile_list(2625)-1599: password:

```

## diagnose test application nr5gd 15

Show modem1 signal and band status.

```
FortiWiFi-50G-5G # diagnose test application nr5gd 15
temperature = 34,
modem_mode = 5,
system_mode = QMI_GMS_SYSTEM_MODE_NR5G_SA,
ims_reg_state = 4,
ps_state = QMI_GMS_PS_STATE_ATTACHED,
nr5g_info.band = 41,
nr5g_info.bandwidth = QMI_GMS_NR5G_BANDWIDTH_400_MHz,
nr5g_info.rx_chan = 501390,
nr5g_info.tx_chan = 501390,
nr5g_info.rssi = -81,
nr5g_info.rsrp = -91,
nr5g_info.rsrq = -10,
nr5g_info.snr = 175,
nr5g_info.pci = 398,
```

## diagnose test application nr5gd 22

Test modem1 warm reboot.

```
FortiWiFi-50G-5G # diagnose test application nr5gd 22
Triggered modem1 warm reboot.
```

## diagnose test application nr5gd 23

Test modem1 power on GPIO.

```
FortiWiFi-50G-5G # diagnose test application nr5gd 23
Triggered modem1 power on GPIO.
```

## diagnose test application nr5gd 24

Test modem1 power off GPIO.

```
FortiWiFi-50G-5G # diagnose test application nr5gd 24
Triggered modem1 power off GPIO.
```

## diagnose test application nr5gd 25

Test modem1 disconnection from and then reconnection to the network.

```
FortiWiFi-50G-5G # diagnose test application nr5gd 25
Triggered modem1 stop network then reconnect.
```

## diagnose test application nr5gd 26

Test modem1 SIM switch.

```
FortiWiFi-50G-5G # dia sys 5g-modem sim-info
-----
Active Slot: SLOT-2
-----
SLOT-1 status:SIM_CARD_PRESENT
SLOT-1 ICCID:00000000000000000000
-----
SLOT-2 status:ABSENT
SLOT-2 ICCID:
SLOT-2 IMSI:
SLOT-2 Country:
SLOT-2 Network:
SLOT-2 PIN status:Unknown
-----

FortiWiFi-50G-5G # diagnose test application nr5gd 26

FortiWiFi-50G-5G # dia sys 5g-modem sim-info
-----
Active Slot: SLOT-1
-----
SLOT-1 status:SIM_CARD_PRESENT
SLOT-1 ICCID:00000000000000000000
SLOT-1 IMSI:0000000000000000
SLOT-1 Country:United States
SLOT-1 Network:Verizon
SLOT-1 PIN status:Ready
-----
SLOT-2 status:ABSENT
```

```
SLOT-2 ICCID:  
-----
```

## diagnose test application nr5gd 27

Test modem1 custom wireless profile cleanup.

```
FortiWiFi-50G-5G # dia test application nr5gd 27  
Triggered modem1 wireless profile(ftnt_custom) cleanup.
```

## diagnose test application nr5gd 28

Test rebooting the current active SIM module in modem1.



The command runs the following command to enable debug mode to show log details after reboot current active SIM module.

```
diagnose dedug application nr5gd  
diagnose debug enable
```

```
FortiWiFi-50G-5G # diagnose test application nr5gd 28  
[NR5G_MODEM1]uim_power_down(1140)-1631: Acquired client id 5  
[NR5G_MODEM1]modem1_sim_event_call_cb(1241)-1631: QMI_UIM_GET_SLOTS_STATUS_IND triggered!  
[NR5G_MODEM1]MDM_SIM_info_expire(961)-1631: MDM_SIM_info_expire event triggered, current state:ST_  
MODEM_CONNECTED  
[NR5G_MODEM1]modem1_sim_event_call_cb(1221)-1631: QMI_UIM_STATUS_CHANGE_IND triggered!  
[NR5G_MODEM1]modem1_sim_event_call_cb(1224)-1631: card_state: SIM_CARD_ERROR  
[NR5G_MODEM1]modem1_sim_event_call_cb(1233)-1631: error: QMI_UIM_CARD_ERROR_CODE_POWER_DOWN  
[NR5G_MODEM1]MDM_SIM_error(940)-1631: MDM_SIM_error event triggered, current state:ST_MODEM_  
CONNECTED  
[NR5G_MODEM1]uim_power_down(1153)-1631: UIM power down slot  
[NR5G_MODEM1]modem1_ipv4_data_call_cb(2654)-1631: data call status QMI_WDS_DATA_CALL_TERMINATED  
[NR5G_MODEM1]MDM_IPV4_drop(1078)-1631: MDM_IPV4_drop event triggered, current state:ST_MODEM_  
CONNECTED  
[NR5G_MODEM1]modem1_ipv4_data_call_cb(2654)-1631: data call status QMI_WDS_DATA_CALL_TERMINATED  
[NR5G_MODEM1]MDM_IPV4_drop(1078)-1631: MDM_IPV4_drop event triggered, current state:ST_MODEM_  
CONNECTED  
[NR5G_MODEM1]modem1_ipv4_data_call_cb(2654)-1631: data call status QMI_WDS_DATA_CALL_TERMINATED  
[NR5G_MODEM1]MDM_IPV4_drop(1078)-1631: MDM_IPV4_drop event triggered, current state:ST_MODEM_  
CONNECTED  
[NR5G_MODEM1]modem1_ipv4_data_call_cb(2654)-1631: data call status QMI_WDS_DATA_CALL_TERMINATED  
[NR5G_MODEM1]MDM_IPV4_drop(1078)-1631: MDM_IPV4_drop event triggered, current state:ST_MODEM_  
CONNECTED
```

## **diagnose test application nr5gd 29**

Test modem1 reset.

## **diagnose test application nr5gd 30**

Test modem1 power supply on.

# IPv6 for 5G WWAN interface

This section describes IPv6 functionality and operational behavior for the 5G WWAN interface on FortiWiFi-50G-5G running FortiOS 7.6.5. FWF-50G-5G supports full IPv6 connectivity over 5G WWAN with the following capabilities:

- [IPv6 auto-configuration \(SLAAC\) on page 46](#)
- [Verifying IPv6 connectivity on page 46](#)
- [Viewing data session information on page 47](#)
- [IPv6 event logging on page 49](#)

## IPv6 auto-configuration (SLAAC)

IPv6 auto-configuration controls whether the system obtains IPv6 addressing via SLAAC. You can use the "diagnose sys 5g-modem data-session-info" command to view SLAAC status.



IPv6 address and gateway are shown onscreen only when SLAAC is disabled. When SLAAC is enabled, IPv6 address and gateway are not displayed in the output.

## Verifying IPv6 connectivity

### diagnose ipv6 address list | wwan

Verify IPv6 address on the WWAN interface.

```
diagnose ipv6 address list | grep wwan
```

The IPv6 address shown should match the session information when SLAAC is disabled.

### execute ping6-options interface wwan

Verify if IPv6 ping works.

```
FortiWiFi-50G-5G (Interim)# execute ping6-options interface wwan
```

```
FortiWiFi-50G-5G (Interim)# exe ping6 2001:4860:4860::8888
PING 2001:4860:4860::8888(2001:4860:4860::8888) 56 data bytes
64 bytes from 2001:4860:4860::8888: icmp_seq=1 ttl=114 time=47.4 ms
64 bytes from 2001:4860:4860::8888: icmp_seq=2 ttl=114 time=46.9 ms
64 bytes from 2001:4860:4860::8888: icmp_seq=3 ttl=114 time=44.9 ms
```

```
64 bytes from 2001:4860:4860::8888: icmp_seq=4 ttl=114 time=42.9 ms
64 bytes from 2001:4860:4860::8888: icmp_seq=5 ttl=114 time=41.9 ms
--- 2001:4860:4860::8888 ping statistics ---
5 packets transmitted, 5 packets received, 0% packet loss, time 4003ms
rtt min/avg/max/mdev = 41.921/44.820/47.443/2.162 ms
```

## Viewing data session information

```
diagnose sys 5g-modem data-session-info
```

Show data session information.

- [Example 1: IPv4v6 PDP + autoconf Disabled \(Default\) on page 47](#)
- [Example 2: IPv4v6 PDP + autoconf Enabled on page 47](#)
- [Example 3: IPv6 PDP + autoconf Disabled on page 48](#)
- [Example 4: IPv6 PDP + autoconf Enabled on page 48](#)

### Example 1: IPv4v6 PDP + autoconf Disabled (Default)

```
FortiWiFi-50G-5G (Interim)# diagnose sys 5g-modem data-session-info
-----
Data session information:
-----
IPV4 connection: QMI_WDS_CONNECTION_STATUS_CONNECTED
Profile index: 3
Profile PDP type: QMI_WDS_PDP_TYPE_IPV4V6
Profile APN name: vzwinternet
IPV4 IP: 000.000.000.000
IPV4 gateway: 000.000.000.000
IPV4 netmask: 255.255.255.000
IPV4 primary DNS: 000.000.000.000
IPV4 secondary DNS: 000.000.000.000
MTU: 1428
-----
IPV6 connection: QMI_WDS_CONNECTION_STATUS_CONNECTED
IPV6 auto-configuration(SLAAC): disabled
Profile index: 3
Profile PDP type: QMI_WDS_PDP_TYPE_IPV4V6
Profile APN name: vzwinternet
IPV6 IP: 0000:0000:0000:00c0:e000:dcf0:00bf:0000/00
IPV6 gateway: 0000:0000:b000:00c0:00a0:00c0:0000:0000/00
IPV6 primary DNS: 0000:0000:00:ff00:000:d:0:0
IPV6 secondary DNS: 0000:0000:00:ff00:000:d:0:0
MTU: 1428
-----
```

### Example 2: IPv4v6 PDP + autoconf Enabled

```
FortiWiFi-50G-5G (Interim)# diagnose sys 5g-modem data-session-info
-----
Data session information:
```

```

-----
IPV4 connection: QMI_WDS_CONNECTION_STATUS_CONNECTED
Profile index: 3
Profile PDP type: QMI_WDS_PDP_TYPE_IPV4V6
Profile APN name: vzwinternet
IPV4 IP: 000.00.000.00
IPV4 gateway: 000.00.000.00
IPV4 netmask: 255.255.255.000
IPV4 primary DNS: 000.000.000.000
IPV4 secondary DNS: 000.000.000.000
MTU: 1428
-----
IPV6 connection: QMI_WDS_CONNECTION_STATUS_CONNECTED
IPV6 auto-configuration(SLAAC): enabled
Profile index: 3
Profile PDP type: QMI_WDS_PDP_TYPE_IPV4V6
Profile APN name: vzwinternet
IPV6 primary DNS: 0000:0000:00:ff00:000:d:0:0
IPV6 secondary DNS: 0000:0000:00:ff00:000:d:0:0

```

### Example 3: IPv6 PDP + autoconf Disabled

```

FortiWiFi-50G-5G (Interim)# diagnose sys 5g-modem data-session-info
-----
Data session information:
-----
IPV6 connection: QMI_WDS_CONNECTION_STATUS_CONNECTED
IPV6 auto-configuration(SLAAC): disabled
Profile index: 8
Profile name: ftnt_custom
Profile PDP type: QMI_WDS_PDP_TYPE_IPV6
Profile APN name: vzwinternet
IPV6 IP: 0000:0000:b0bd:0f0d:0d0:b000:000:f000/00
IPV6 gateway: 0000:0000:b0bd:0f0d:a00c:00ca:0f0c:e0a0/00
IPV6 primary DNS: 0000:0000:00:ff00:000:d:0:0
IPV6 secondary DNS: 0000:0000:00:ff00:000:d:0:0
MTU: 1428
-----

```

### Example 4: IPv6 PDP + autoconf Enabled

```

FortiWiFi-50G-5G (Interim)# diagnose sys 5g-modem data-session-info
-----
Data session information:
-----
IPV6 connection: QMI_WDS_CONNECTION_STATUS_CONNECTED
IPV6 auto-configuration(SLAAC): enabled
Profile index: 8
Profile name: ftnt_custom
Profile PDP type: QMI_WDS_PDP_TYPE_IPV6
Profile APN name: vzwinternet
IPV6 primary DNS: 0000:0000:00:ff00:000:d:0:0
IPV6 secondary DNS: 0000:0000:00:ff00:000:d:0:0
MTU: 1428
-----

```

# IPv6 event logging

The system event log records the following IPv6 session changes:

## IPv6 address change

```
FortiWiFi-50G-5G (Interim)# execute log filter category 1

FortiWiFi-50G-5G (Interim)# execute log filter field logid 0100046715

FortiWiFi-50G-5G (Interim)# execute log display
15 logs found.
10 logs returned.

1: date=2025-09-22 time=10:42:20 eventtime=1758562940848420849 tz="-0700" logid="0100046715"
type="event" subtype="system" level="information" vd="root" logdesc="5G modem IPV6 IP address
changed" modem="1" msg="modem1 IPV6 address changed to 0000:0000:b000:0d00:d000:edff:feb0:d000"

2: date=2025-09-22 time=10:34:40 eventtime=1758562479972268412 tz="-0700" logid="0100046715"
type="event" subtype="system" level="information" vd="root" logdesc="5G modem IPV6 IP address
changed" modem="1" msg="modem1 IPV6 address changed to 0000:0000:b000:0d00:000e:0e0e:000d:fe0c"
```

## IPv6 link state change

```
FortiWiFi-50G-5G (Interim)# execute log filter field logid 0100046714

FortiWiFi-50G-5G (Interim)# execute log display
15 logs found.
10 logs returned.

1: date=2025-09-22 time=11:26:22 eventtime=1758565582157363135 tz="-0700" logid="0100046714"
type="event" subtype="system" level="information" vd="root" logdesc="5G modem IPV6 link state
changed" modem="1" state="disconnected" msg="Internal modem1 IPV6 link disconnected"

2: date=2025-09-22 time=10:47:49 eventtime=1758563268994523603 tz="-0700" logid="0100046714"
type="event" subtype="system" level="information" vd="root" logdesc="5G modem IPV6 link state
changed" modem="1" state="connected" msg="Internal modem1 IPV6 link connected"
```

# Using eSIM

FGR-60G-5G-Series devices support embedded SIM (eSIM), which allows devices to seamlessly switch between a physical SIM card and an eSIM profile.

This section discusses how to configure and operate the following eSIM features:

- Support for multiple eSIM profiles with remote provisioning.
- Seamless profile switching without reboot.
- Ability to fallback to physical SIM when eSIM is disabled.

## Preparation

Before using eSIM, you must do the following:

1. Obtain a valid eSIM (verification code and SM-DP address should be available).
2. Insert a physical SIM card in SIM slot 1.
3. (Optional) Insert a physical SIM card in SIM slot 2.

## CLI commands for eSIM

Use the following commands to configure and manage the eSIM.

- [default](#) on page 50
- [set esim enable](#) on page 51
- [execute 5g-modem esim profile download <activation code>](#) on page 52
- [execute 5g-modem esim profile list](#) on page 53
- [execute 5g-modem esim profile enable](#) on page 53
- [execute 5g-modem esim profile disable](#) on page 55
- [execute 5g-modem esim profile delete](#) on page 56
- [unset esim](#) on page 57
- [eSIM log](#) on page 62

### default

By default, eSIM is disabled. When eSIM is disabled, the device automatically switches to the physical SIM card, as shown in the following code example:

```
FortiGateRugged-60G-5G-M12 (STS)# diagnose sys 5g-modem sim-info
```

```
-----
```

```
SIM information:
```

```
-----
```

```
Active Slot: SLOT-1
```

```
eSIM status: Disabled >>>> esim is disabled by default.
```

```
-----
```

```
SLOT-1 status:SIM_CARD_PRESENT
```

```
SLOT-1 ICCID:000000000000000000
```

```
SLOT-1 MSISDN: +0000000000
```

```
SLOT-1 IMSI:0000000000000000
```

```
SLOT-1 Country:United States of America
```

```
SLOT-1 Network:Verizon
```

```
SLOT-1 PIN status:Ready
```

```
-----
```

```
SLOT-2 status:ABSENT
```

```
SLOT-2 ICCID:
```

```
-----
```

## set esim enable

Enable eSIM.

```
FortiGateRugged-60G-5G-M12 (5g-modem) (STS)# show
```

```
config system 5g-modem
```

```
config modem1
```

```
set esim enable
```

```
end
```

```
end
```



When eSIM is enabled, it will always be in Slot 2 to work, no matter whether there's a physical SIM card in Slot 1 or Slot 2.

```
FortiGateRugged-60G-5G-M12 (STS)# diagnose sys 5g-modem sim-info
```

```
-----  
SIM information:  
-----
```

```
Active Slot: SLOT-1
```

```
eSIM status: Enabled(SLOT-2) >>>> esim is enabled and on slot 2.  
-----
```

```
SLOT-1 status:SIM_CARD_PRESENT
```

```
SLOT-1 ICCID:000000000000000000
```

```
SLOT-1 MSISDN: +0000000000
```

```
SLOT-1 IMSI:0000000000000000
```

```
SLOT-1 Country:United States of America
```

```
SLOT-1 Network:Verizon
```

```
SLOT-1 PIN status:Ready  
-----
```

```
SLOT-2 status:SIM_CARD_PRESENT
```

```
SLOT-2 ICCID:  
-----
```



The following eSIM-related operations can only be executed when eSIM is in the active slot, i.e., Slot 2. If not, use the "diagnose test application nr5gd 26" command to trigger modem1 sim switch.

## execute 5g-modem esim profile download <activation code>

Download eSIM profile.

```
FortiGateRugged-60G-5G-M12 (STS)# execute 5g-modem esim profile download  
LPA:1$wbg.prod.ondemandconnectivity.com$40AG356ACXXNEC3N
```

This command sends a network request and may take up to 60 seconds to respond.

Please wait...

```
-----  
eSIM profile successfully downloaded  
-----
```

## execute 5g-modem esim profile list

Check eSIM profile.

```
FortiGateRugged-60G-5G-M12 (STS)# execute 5g-modem esim profile list
```

```
-----
```

Profile index: 0

ICCID: 000000000000000000

eSIM Profile Status: Disabled

```
-----
```

## execute 5g-modem esim profile enable

Enable eSIM profile.

```
FortiGateRugged-60G-5G-M12 (STS)# execute 5g-modem esim profile enable 0
```

```
-----
```

eSIM Profile successfully enabled.

```
-----
```



After eSIM profile is enabled, the 5G modem should get network signal.

---

```
FortiGateRugged-60G-5G-M12 (STS)# diagnose sys 5g-modem sim-info
```

```
-----  
SIM information:  
-----  
Active Slot: SLOT-2(eSIM)  
eSIM status: Enabled(SLOT-2)  
-----  
SLOT-1 status:SIM_CARD_PRESENT  
SLOT-1 ICCID:00000000000000000000  
-----  
SLOT-2 status:SIM_CARD_PRESENT  
SLOT-2 EID: 0000000000000000000047446133076  
SLOT-2 ICCID:00000000000000000000  
SLOT-2 MSISDN:  
SLOT-2 IMSI:0000000000000000  
SLOT-2 Country:Hong Kong  
SLOT-2 Network:454 35  
SLOT-2 PIN status:Ready  
-----  
FortiGateRugged-60G-5G-M12 (STS)# diagnose sys 5g-modem data-session-info  
-----  
Data session information:  
-----  
IPV4 connection: QMI_WDS_CONNECTION_STATUS_CONNECTED  
Profile index: 1  
Profile name: profile1  
Profile PDP type: QMI_WDS_PDP_TYPE_IPV4
```

```
Profile APN name:
IPV4 IP: 00.000.00.00
IPV4 gateway: 00.000.00.00
IPV4 netmask: 255.255.255.000
IPV4 primary DNS: 0.0.0.0
IPV4 secondary DNS: 0.0.0.0
MTU: 1460
-----

FortiGateRugged-60G-5G-M12 (STS)# execute ping-options interface wwan

FortiGateRugged-60G-5G-M12 (STS)# execute ping 0.0.0.0
PING 0.0.0.0 (0.0.0.0): 56 data bytes
64 bytes from 0.0.0.0: icmp_seq=0 ttl=116 time=203.5 ms
64 bytes from 0.0.0.0: icmp_seq=1 ttl=116 time=93.2 ms
^C
--- 0.0.0.0 ping statistics ---
2 packets transmitted, 2 packets received, 0% packet loss
round-trip min/avg/max = 93.2/148.3/203.5 ms
```

## execute 5g-modem esim profile disable

Disable eSIM profile.

```
FortiGateRugged-60G-5G-M12 (STS)# execute 5g-modem esim profile disable 0
-----
eSIM Profile successfully disabled.
-----
```

## execute 5g-modem esim profile delete

Delete eSIM profile.



An eSIM profile can be deleted only after it has been disabled. Otherwise, the operation will fail and a warning message will be displayed.

```
FortiGateRugged-60G-5G-M12 (STS)# execute 5g-modem esim profile list
-----
Profile index: 0
ICCID: 00000000000000000000
eSIM Profile Status: Enabled
-----

FortiGateRugged-60G-5G-M12 (STS)# execute 5g-modem esim profile delete 0
-----
Failed to delete profile #0, reason:LPA_ERROR_LOCAL_PROFILE_NOT_IN_DISABLE_STATE
-----

FortiGateRugged-60G-5G-M12 (STS)# execute 5g-modem esim profile list
-----
Profile index: 0
ICCID: 00000000000000000000
eSIM Profile Status: Disabled

FortiGateRugged-60G-5G-M12 (STS)# execute 5g-modem esim profile delete 0
-----
Profile #0 deleted successfully.
-----
```

## unset esim

Use "unset esim" or "set esim disable" to turn off the eSIM function. If a physical SIM card is present in slot 1, the active slot will automatically switch to slot 1.

```
FortiGateRugged-60G-5G-M12 (5g-modem) (STS)# show
config system 5g-modem

config modem1

set esim enable

end

end

FortiGateRugged-60G-5G-M12 (5g-modem) (STS)# config modem1

FortiGateRugged-60G-5G-M12 (modem1) (STS)# unset esim

FortiGateRugged-60G-5G-M12 (modem1) (STS)# end

FortiGateRugged-60G-5G-M12 (5g-modem) (STS)# show

config system 5g-modem

config modem1

end

end

FortiGateRugged-60G-5G-M12 (STS)# diagnose sys 5g-modem sim-info

-----

SIM information:

-----

Active Slot: SLOT-1

eSIM status: Disabled

-----

SLOT-1 status:SIM_CARD_PRESENT
```

```
SLOT-1 ICCID:0000000000024434254
SLOT-1 MSISDN: +0000000000
SLOT-1 IMSI:000000000000000
SLOT-1 Country:United States of America
SLOT-1 Network:Verizon
SLOT-1 PIN status:Ready
-----
SLOT-2 status:ABSENT
SLOT-2 ICCID:
-----
```



When eSIM is disabled (default) and Slot 2 also has a physical SIM card, both Slot 1 and Slot 2 operate as regular physical SIM slots. See the following code example.

---

```
FortiGateRugged-60G-5G-M12 (STS)# diagnose sys 5g-modem sim-info
-----
SIM information:
-----
Active Slot: SLOT-1
eSIM status: Disabled
-----
SLOT-1 status:SIM_CARD_PRESENT
SLOT-1 ICCID:0000000000024434254
SLOT-1 MSISDN: +0000000000
SLOT-1 IMSI:000000000000000
SLOT-1 Country:United States of America
SLOT-1 Network:Verizon
SLOT-1 PIN status:Ready
```

```
-----  
SLOT-2 status:SIM_CARD_PRESENT  
SLOT-2 ICCID:00000000009178732642  
-----  
  
FortiGateRugged-60G-5G-M12 (STS)# diagnose sys 5g-modem sim-info  
-----  
SIM information:  
-----  
Active Slot: SLOT-2  
eSIM status: Disabled  
-----  
SLOT-1 status:SIM_CARD_PRESENT  
SLOT-1 ICCID:0000000000024434254  
-----  
SLOT-2 status:SIM_CARD_PRESENT  
SLOT-2 ICCID:00000000009178732642  
SLOT-2 MSISDN: +0000000000  
SLOT-2 IMSI:000000000000000  
SLOT-2 Country:United States of America  
SLOT-2 Network:Verizon  
SLOT-2 PIN status:Ready  
-----
```



When eSIM is enabled, it takes over Slot 2, and the physical SIM card in Slot 2 will stop working, as shown in the following code example.

```
FortiGateRugged-60G-5G-M12 (5g-modem) (STS)# show  
config system 5g-modem
```

```
config modem1
set esim enable
end
end

FortiGateRugged-60G-5G-M12 (STS)# diagnose sys 5g-modem sim-info

-----
SIM information:
-----
Active Slot: SLOT-2(eSIM)
eSIM status: Enabled(SLOT-2)
-----
SLOT-1 status:SIM_CARD_PRESENT
SLOT-1 ICCID:00000000000024434254
-----
SLOT-2 status:SIM_CARD_PRESENT
SLOT-2 EID: 000000000000000000047446133076
SLOT-2 ICCID:000000000000000000
SLOT-2 MSISDN:
SLOT-2 IMSI:0000000000000000
SLOT-2 Country:Hong Kong
SLOT-2 Network:454 35
SLOT-2 PIN status:Ready
-----
```



Even when eSIM profile is disabled or out of data, the physical SIM card in Slot 2 won't work as long as you "set esim enable".

---

```
FortiGateRugged-60G-5G-M12 (STS)# diagnose sys 5g-modem sim-info
-----
SIM information:
-----
Active Slot: SLOT-2(eSIM)
eSIM status: Enabled(SLOT-2)
-----
SLOT-1 status:SIM_CARD_PRESENT
SLOT-1 ICCID:00000000000024434254
-----
SLOT-2 status:SIM_CARD_PRESENT
SLOT-2 EID: 0000000000000000000047446133076
SLOT-2 ICCID:
SLOT-2 MSISDN:
SLOT-2 IMSI:
SLOT-2 Country:
SLOT-2 Network:
SLOT-2 PIN status:Unknown
-----
```



You can trigger the 5G modem1 auto-sim-switch by disconnecting it over 300 seconds (default), and Slot 1 will become the active slot.

---

```
FortiGateRugged-60G-5G-M12 (STS)# diagnose sys 5g-modem sim-info
-----
SIM information:
-----
Active Slot: SLOT-1
```

```

eSIM status: Enabled(SLOT-2)

-----

SLOT-1 status:SIM_CARD_PRESENT

SLOT-1 ICCID:00000000000024434254

SLOT-1 MSISDN: +0000000000

SLOT-1 IMSI:000000000000000

SLOT-1 Country:United States of America

SLOT-1 Network:Verizon

SLOT-1 PIN status:Ready

-----

SLOT-2 status:SIM_CARD_PRESENT

SLOT-2 ICCID:

-----

```

## eSIM log

Using the "set esim enable" or "set esim disable" command triggers a log entry of LogID=46714, capturing 5G modem eSIM events.

- ```

date=2025-06-23 time=17:20:05 eventtime=1750724405329601050 tz="-0700" logid="0100046714"
type="event" subtype="system" level="information" vd="root" logdesc="5G modem eSIM event"
modem="1" msg="modem1 ESIM disabled"

```
- ```

date=2025-06-23 time=17:05:20 eventtime=1750723520224535009 tz="-0700" logid="0100046714"
type="event" subtype="system" level="information" vd="root" logdesc="5G modem eSIM event"
modem="1" msg="modem1 ESIM enabled"

```

## Supported eSIM providers

The following table provides a comparison of our supported eSIM vendors. It includes sample pricing for North America and shows how each vendor delivers the activation code, whether their official app is required, and if any third-party tool is needed. This helps users choose the most convenient option for their needs.

Vendor	Plan type	Data	Pricing (\$US)	Validity	Activation code	Third-party tool
Airalo	Regional eSIM	1 GB	\$6.50	7 days	In vendor app	No
Saily	Regional eSIM	1 GB	\$5.99	7 days	QR only (manual convert)	For QR > Activation Code
HolaFly	Regional eSIM	Unlimited	\$6.90	1 day	Email	No
Nomad	Regional eSIM	1 GB	\$8.00	7 days	Email	No
GigSky	Regional eSIM	1 GB	\$7.99	7 days	QR only (manual convert)	For QR > Activation Code
GigSky	Regional eSIM	Unlimited	\$7.99	1 day	QR only (manual convert)	For QR > Activation Code

# MIBs

All information invoked by the various "diagnose sys 5g-modem" commands is available as read-only MIB entries.

This section discusses how to access and interpret the information in MIB files about the internal 5G modem.

- [Download MIB files on page 64](#)
- [Enable SNMP support on page 65](#)
- [Create SNMP community on page 65](#)
- [Allow SNMP access on page 66](#)
- [Configure MIB browser on page 67](#)
- [Browse for MIB entries on page 68](#)

## Download MIB files

FortiGate has two MIB files: FortiGate MIB file and Fortinet Core MIB file. The common Fortinet Core MIB (FORTINET-CORE-MIB.mib) file is required for SNMP monitoring.

### To download the MIB files from the FortiGate GUI:

1. From the main menu, select *Systems>SNMP*.
2. On the *SNMP* page, click the Download buttons to download the MIB files.

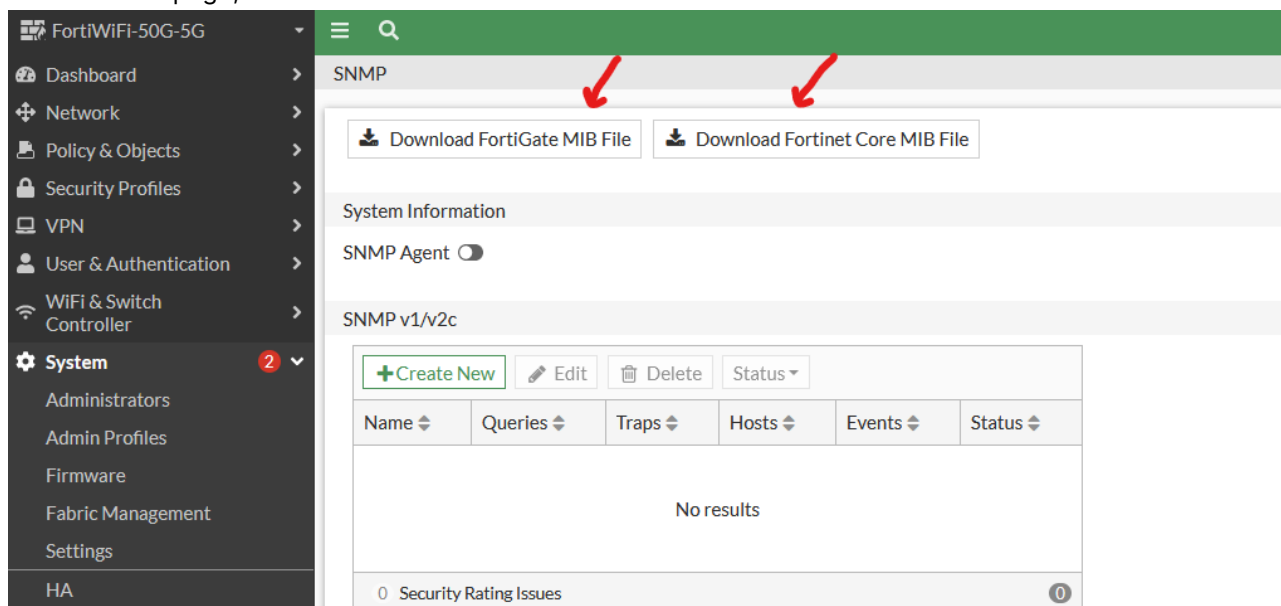

# Enable SNMP support

## To enable SNMP support:

1. On the *SNMP* page (see above), enable *SNMP Agent* to make the FortiGate an SNMP agent.
2. Enter a brief description.
3. Click *Apply*.

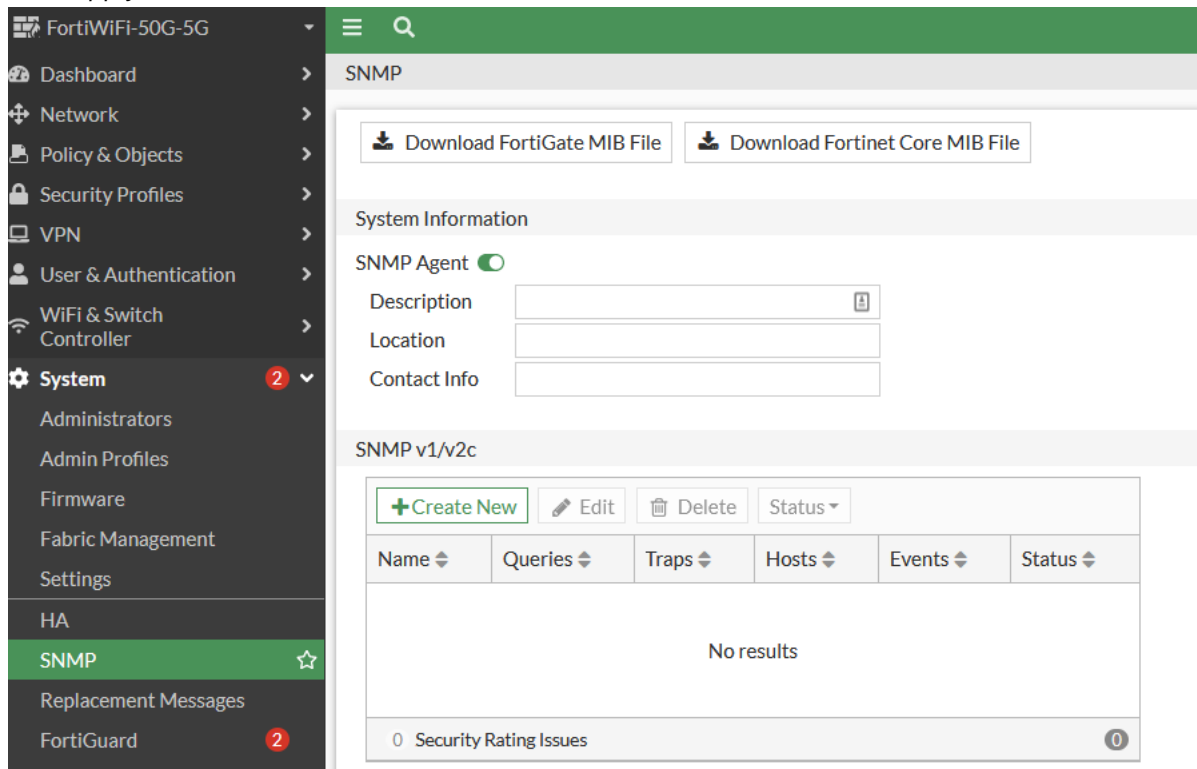

# Create SNMP community

## To create an SNMP community:

1. On the *SNMP* page, under the *SNMPv1/v2c* section, click *Create New*.  
The New SNMP Community configuration dialog opens.
2. Specify the *Community Name*, e.g., 5g.
3. Specify the address of the SNMP hosts, and set *Host Type* to *Accept queries and send traps*.
4. Make the other desired selections.
5. Click *OK*.

The following illustrations show the configuration of an SNMP community named "5g".

**New SNMP Community**

Community Name

Enabled

---

**Hosts**

IP Address

Host Type

---

**Queries**

v1 Enabled

Port

v2c Enabled

Port

---

**Traps**

v1 Enabled

Local Port

Remote Port

v2c Enabled

Local Port

Remote Port

SNMP v1/v2c					
<input type="button" value="+ Create New"/> <input type="button" value="Edit"/> <input type="button" value="Delete"/> <input type="button" value="Status"/>					
Name	Queries	Traps	Hosts	Events	Status
5g	<input checked="" type="checkbox"/> v1 Enable <input checked="" type="checkbox"/> v2 Enable	<input checked="" type="checkbox"/> v1 Enable <input checked="" type="checkbox"/> v2 Enable	0.0.0/0	40	<input checked="" type="checkbox"/> Enable
0 Security Rating Issues					1

## Allow SNMP access

Assuming that you use the WAN interface to access MIB information, you must ensure that SNMP is enabled on that interface.

### To verify if SNMP is enabled on the WAN interface of your Fortinet 5G device:

1. Click *Network>Interfaces*.
2. Under *Physical (2)*, in the Access column, make sure that *SNMP* is present, as illustrated in the following screen shot.



3. If for some reason SNMP is not enabled on the wan interface, enable it using the following procedures:
  - a. Double-click the wan interface (refer to the image above) to open its configuration page.
  - b. Under *Administrative Access*, select *SNMP*, as illustrated in the following screen shot.
  - c. Click *OK*.

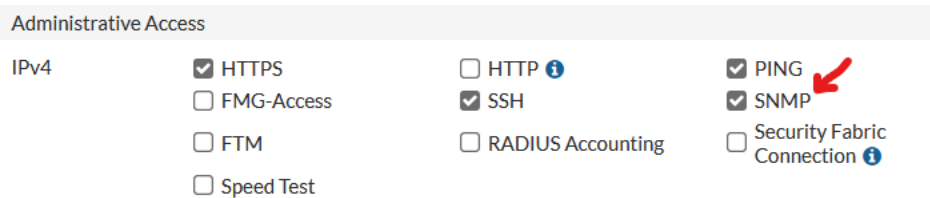

## Configure MIB browser

You need a MIB browser to pull data from SNMP agents such as routers, switches, and servers (FortiGate in this case). In addition, a MIB browser also enables you to retrieve and display MIB data in a human-readable form.

The following example shows the configuration and use of the iReasoning MIB browser. Make sure that the information you enter in the MIB browser matches what is on the SNMP agent (FortiGate).

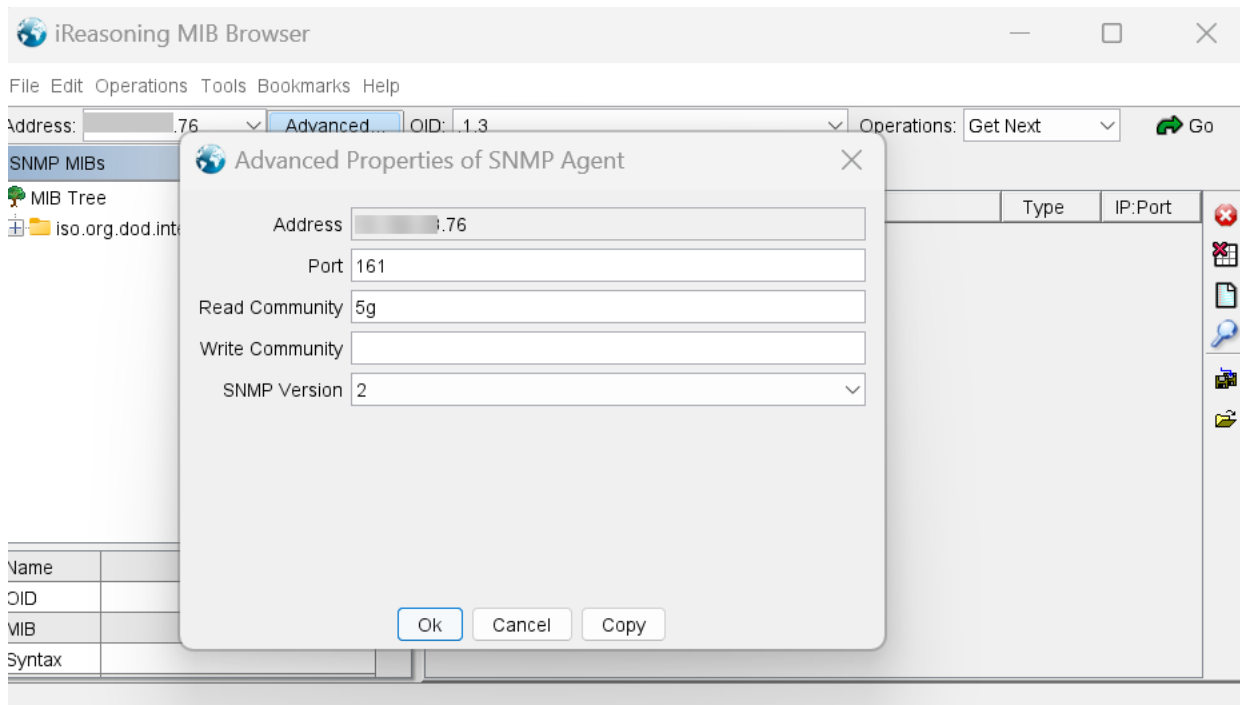

Parameter	Description
<i>Address</i>	The address of the SNMP agent (i.e., the FortiGate device).
<i>Port</i>	The port used for SNMP queries on the SNMP agent.
<i>Read Community</i>	The name of the SNMP Read community.
<i>Write Community</i>	The name of the SNMP Write community. <b>Note:</b> Leave this field blank because it is not supported on FortiGate.
<i>SNMP Version</i>	The version of SNMP used by the SNMP agent.

## Browse for MIB entries

The following screen shot shows the path used to browse for MIB information about the internal 5G modem in a FortiGate.

iReasoning MIB Browser

File Edit Operations Tools Bookmarks Help

Address: .76 Advanced... OID: .1.3.6.1.4.1.12356.101.25

SNMP MIBs

- enterprises
  - fortinet
    - fnCoreMib
    - fnFortiGateMib
      - fgModel
      - fgTraps
      - fgVirtualDomain
      - fgSystem
      - fgFirewall
      - fgMgmt
      - fgIntf
      - fgAntivirus
      - fgIps
      - fgApplications
      - fgInetProto
      - fgVpn
      - fgHighAvailability
      - fgWc
      - fgFc
      - fgServerLoadBalance
      - fgUsbModemInfo
      - fgDevice
      - fgInternalLTEModemsInfo
      - fgNPU
      - fgLog
      - fgConfig
      - fgDhcp
      - fgSw
      - fgInternal5GModemsInfo**
        - fgMdmInfo
          - fgMdmInfoTable
          - fgSimInfoTable
          - fgSignalInfoTable
          - fgTrafficInfoTable
          - fgSessInfoTable



FortiWiFi 50G-5G and FortiRugged FGR-5G-Dual devices do not come with a log disk.

By default, only events with severity level of *Warning* or higher are logged. To show a log sample quickly, you can temporarily lower the log severity to *Info* so that all modem events will be logged. We recommend using the default severity level of *Warning* to conserve system memory.

The following are the logged modem events:

- Modem detection
- Modem initialized
- GPS daemon up/down
- Modem firmware upgrade
- Modem reboot
- Modem operation mode changed
- Modem power on/off
- Modem SIM card state changed
- Modem data link connected/disconnected
- Modem IP address changed
- Modem 5G signal mode changed

The syslog is available for the internal 5G modem only. The following screen shot is an example of syslog for the internal 5G modem.

Date/Time	Level	User	Message	Log Description	Log Details
3 minutes ago	Warning	auto-join	FortiCloud service activation failed	FortiGate Cloud activation failed	General
3 minutes ago	Warning	auto-join	Attempted to join FortiCloud	FortiGate Cloud auto-join attempted	Absolute Date/Time 2024/02/15 18:03:16 Time 18:03:16 Virtual Domain root Log Description 5G modem1 link up.
4 minutes ago	Info		modem1 IPv4 address changed from 10.175.53.79 to 10.135.183.96	5G modem1 IPv4 IP address changed	Source
4 minutes ago	Info		interface wwan gets a DHCP lease, ip:10.135.183.96, mask:255.255.255...	DHCP client lease granted	User
4 minutes ago	Info		Fortigate scheduled update fcnl=yes fdnl=yes fsci=yes from 173.243.141...	FortiGate update succeeded	Security
4 minutes ago	Info		Internal modem1 IPv4 link connected	5G modem1 link up.	Event
4 minutes ago	Info		Internal modem1 initialized, ready to accept user commands	5G modem1 initialized.	Message Internal modem1 IPv4 link connected
4 minutes ago	Info		Internal modem1 GPS enabled	5G modem1 GPS event	Other
4 minutes ago	Info		Performance statistics: average CPU: 40, memory: 29, concurrent session...	System performance statistics	Log event original timestamp 1708048996292430000 Timezone -0800 Log ID 0100046703 Type event Sub Type system
4 minutes ago	Info		Internal modem1 detected, vender ID:0x1bc7, product ID:0x1070	5G modem1 detected	
5 minutes ago	Info		Internal modem1 cold rebooted	5G modem1 rebooted	
3 minutes ago	Info		Internal modem1 IPv4 link disconnected	5G modem1 link down	
3 minutes ago	Info		The modem1 is on 3G/4G QMI_GMS_SYSTEM_MODE_LTE mode.	5G modem1 signal mode is 3G/4G.	
3 minutes ago	Info	admin	Edit system.admin admin	Object attribute configured	
3 minutes ago	Info	admin	Edit system.admin admin	Object attribute configured	
3 minutes ago	Info	admin	Edit system.admin admin	Object attribute configured	

For internal LTE modem syslog, please refer to the [3G4G LTE Modem Operator's Manual](#).

# Firmware upgrade

For firmware upgrade, see [5G Device Modem Firmware Upgrade Guide](#).

# Change log

Date	Change Description
2026-02-19	Updated, adding IPv6 for 5G WWAN interface on page 46, Using eSIM on page 50, and a hyperlink to 5G Device Modem Firmware Upgrade Guide.
2024-12-03	Initial release.



[www.fortinet.com](http://www.fortinet.com)

Copyright© 2026 Fortinet, Inc. All rights reserved. Fortinet®, FortiGate®, FortiCare® and FortiGuard®, and certain other marks are registered trademarks of Fortinet, Inc., and other Fortinet names herein may also be registered and/or common law trademarks of Fortinet. All other product or company names may be trademarks of their respective owners. Performance and other metrics contained herein were attained in internal lab tests under ideal conditions, and actual performance and other results may vary. Network variables, different network environments and other conditions may affect performance results. Nothing herein represents any binding commitment by Fortinet, and Fortinet disclaims all warranties, whether express or implied, except to the extent Fortinet enters a binding written contract, signed by Fortinet's Chief Legal Officer, with a purchaser that expressly warrants that the identified product will perform according to certain expressly-identified performance metrics and, in such event, only the specific performance metrics expressly identified in such binding written contract shall be binding on Fortinet. For absolute clarity, any such warranty will be limited to performance in the same ideal conditions as in Fortinet's internal lab tests. Fortinet disclaims in full any covenants, representations, and guarantees pursuant hereto, whether express or implied. Fortinet reserves the right to change, modify, transfer, or otherwise revise this publication without notice, and the most current version of the publication shall be applicable.