



Administration Guide

FortiPAM 1.3.1



FORTINET DOCUMENT LIBRARY

<https://docs.fortinet.com>

FORTINET VIDEO LIBRARY

<https://video.fortinet.com>

FORTINET BLOG

<https://blog.fortinet.com>

CUSTOMER SERVICE & SUPPORT

<https://support.fortinet.com>

FORTINET TRAINING & CERTIFICATION PROGRAM

<https://www.fortinet.com/training-certification>

FORTINET TRAINING INSTITUTE

<https://training.fortinet.com>

FORTIGUARD LABS

<https://www.fortiguard.com>

END USER LICENSE AGREEMENT

<https://www.fortinet.com/doc/legal/EULA.pdf>

FEEDBACK

Email: techdoc@fortinet.com



February 11, 2025

FortiPAM 1.3.1 Administration Guide

74-131-990649-20250211

TABLE OF CONTENTS

Change Log	9
What's new in FortiPAM	10
FortiPAM 1.3.1	10
FortiPAM 1.3.0	10
985657- FortiPAM distributed architecture	10
968457- Display 2FA status	11
913565, 927433- Automated remote user provisioning	11
925187- Display ZTNA launch control inheritance settings for folders	11
883603- vTPM support for FortiPAM on GCP	11
961527- Logs extracted as JSON and CSV file	11
913157, 959127- New Web Telnet launcher	12
957808- Password only viewable to the user checking out a secret	12
839929- Import remote LDAP users	12
878661- New remote server option when creating a remote user	12
963099- Customizing replacement messages	12
975901, 963740- User deletion enhancements	13
964873- Approver minimum permission	13
920066- Approver group email notification for access requests	13
993481- Sync sender name across all emails	13
942734- Log and video disk encryption	14
964619- Immediate secret access on approval	14
954620, 997420- Adjust the timezone for the secret access requestor and approver ...	14
877089- Secret list displays secret creation time	14
955024- Customize Email template for secret request	15
950516- RDP auto token for FortiAuthenticator	15
840054- Auto discovery of secrets	15
893740- Increased secret capacity	15
919801- Updating service account credentials	15
987061- Updated secret logs and active sessions GUI	16
Introduction	17
FortiPAM concepts	18
Organization of the guide	18
Using the GUI	19
Banner	19
GUI based global search	20
CLI commands	20
Admin	21
Tables	25
Modes of operation	29
FortiPAM deployment options	30
Feature availability	33
FortiPAM installation	35
Installing FortiClient with the FortiPAM feature	35
FortiPAM appliance setup	36

FortiPAM with TPM	38
Connecting to target remote systems	40
Licensing	41
License expiry and renewal	43
Renewing FortiPAM-VM license	45
Dashboard	47
Adding a custom dashboard	50
System information widget	50
Licenses widget	52
FortiGuard Distribution Network	52
VM license	56
Secrets	57
Secret list	58
Creating a secret	60
Launching a secret	82
Check out and check in a secret	83
Uploading secrets using the secret upload template	84
Change password	85
Verify password	88
Example secret configurations example	89
Target list	92
Creating a target	93
Gateway	100
Introduction	100
Creating a gateway on the FortiPAM GUI	101
Personal/public folder	106
Creating a folder	110
My requests list	116
Make a request	117
Approval list	119
Approving a request	121
Reviewing multiple requests	122
Job list	123
Creating a job	124
Discovery	126
Creating discovery entry	127
Secret settings	133
Classification tags	133
Creating a classification tag	134
Templates	134
Creating secret templates	137
Launchers	145
Creating a launcher	151
Policies	156
Creating a policy	157
Addresses	163

Creating an address	164
Creating an address group	165
Dependency updater	166
Service accounts	166
Updating service accounts	166
Creating a dependency updater	167
Updating a service account credential Example	168
Approval flow	170
Approval profile	171
Approval email template	175
Creating an approval email template	176
Creating an approval email template using the CLI	179
Password changers	180
Creating a password changer	181
Password policies	188
Creating a password policy	189
Character sets	191
Creating a character set	192
AntiVirus	192
Creating an antivirus profile	193
Data loss prevention (DLP) protection for secrets	195
Supported file types	200
DLP file pattern	202
SSH filter profiles	204
Creating an SSH filter	204
Event filter profile	209
Creating an event filter profile	210
Integrity check	212
Creating a client software entry for integrity check	213
User management	216
User list	216
Creating a user	218
Importing LDAP users	231
User groups	234
Auto provision rules	239
Sponsored groups	240
Role	243
Access control options	251
Log permissions	254
LDAP servers	255
SAML Single Sign-On (SSO)	258
Auto provision rules	261
RADIUS servers	265
Schedule	267
FortiTokens	270

Monitoring	273
User monitor	273
Active sessions	273
Over-the-shoulder monitoring (Live recording)	275
Log & report	277
Secret	277
Events	281
ZTNA	284
SSH	285
Antivirus	287
Data leak prevention	288
Reports	288
General	289
Secret audit	294
Log settings	295
Configuring log and video disk encryption	298
Email alert settings	302
Email alert when the glass breaking mode is activated example	303
Debug settings	304
Automation trigger settings	306
Network	308
Interfaces	308
Creating an interface	309
Creating a zone	312
Static routes	312
Creating an IPv4 static route	313
DNS settings	315
Security fabric	317
Fabric Connectors	317
Packet capture	322
Creating a packet capture filter	322
System	324
Settings	324
Testing the email service connection example	330
How FortiPAM chooses the sender email address	331
ZTNA	332
Editing a proxy rule	332
Creating a ZTNA tag group	335
ZTNA user control	335
ZTNA tag control example	337
ZTNA-based FortiPAM access control	338
High availability	341
HA active-passive cluster setup	345
Upgrading FortiPAM devices in an HA cluster	347
Disaster recovery	348
Certificates	349

Creating a certificate	351
Generating a CSR (Certificate Signing Request)	353
Importing CA certificate	356
Uploading a remote certificate	357
Importing a CRL (Certificate revocation list)	357
Replacement messages	359
Replacement messages descriptions	361
Editing a replacement message	362
Managing images	364
SNMP	367
Fortinet MIBs	369
SNMP agent	370
Creating or editing an SNMP community	371
Creating or editing an SNMP user	373
Backup	374
Sending backup file to a server Example	379
Firmware	380
FortiPAM license	381
Stackable seat license for hardware models	382
FortiGuard license	382
Disclaimers via the CLI	382
Troubleshooting	384
Troubleshoot using trace files	385
Example troubleshooting example	385
FortiPAM HTTP filter	386
Issue: WebRDP session recording fails and closes active session	388
Troubleshooting log and video disk encryption issues	389
Issue 1:	389
Issue 2:	389
Issue 3:	391
Issue 4:	391
FortiClient troubleshooting tips	392
Issue 1: Error contacting FortiClient	392
Issue 2: Error starting the program	393
Issue 3: FortiPAM JSON error	393
Issue 4: HTTP port mismatch between FortiPAM and FortiClient	393
Issue 5: Secret not reaching the host	393
Hardening	394
Secure password storage	394
Verify the private-data-encryption feature Example	395
How to restore a backup configuration file with private-data-encryption enabled	
Example	395
Enabling private-data-encryption on an HA cluster Example	396
Appendix A: Installation on KVM	398
Appendix B: Installation on VMware	401
Appendix C: Installing vTPM package on KVM and adding vTPM to	406

FortiPAM-VM	
Appendix D: vTPM for FortiPAM on VMware	408
Appendix E: Enabling soft RAID on KVM or VMware	409
Appendix F: Installation on Hyper-V	411
Appendix G: Installation on Azure	422
Appendix H: FortiPAM hardware RAID CLI commands	428
Appendix I: Default launchers parameters	431
Appendix J: Installation on AWS	438
FortiPAM installation on AWS and initial setup:	438
Appendix K: Installation on GCP	451
FortiPAM installation on GCP and initial setup:	451
Appendix L: WinRM configuration for Windows server	465
Appendix M: FortiPAM browser extension and standalone FortiClient air-gapped installation	471
Appendix N: Performance test results	474
FortiPAM-VM minimum requirements based on different user seats	474
FortiPAM-VM performance as tested in the lab	474

Change Log

Date	Change Description
2025-01-13	Initial release.
2025-02-11	Updated High availability on page 341 .

What's new in FortiPAM

This section provides a summary of the new features and enhancements in FortiPAM:

- [FortiPAM 1.3.1 on page 10](#)
- [FortiPAM 1.3.0 on page 10](#)

Always review the *FortiPAM Release Notes* on the [Fortinet Docs Library](#) prior to upgrading your device.

FortiPAM 1.3.1

FortiPAM 1.3.1 is a patch release only. There are no new features and enhancements in this release. For more information, see the *FortiPAM 1.3.1 Release Notes* on [Fortinet Docs Library](#).

FortiPAM 1.3.0

The following list contains new and expanded features added in FortiPAM 1.3.0.

985657- FortiPAM distributed architecture

FortiPAM now supports network gateway for distributed target deployment.

FortiPAM allows configuring a gateway, e.g., a FortiPAM, a FortiGate, or a FortiProxy device, when a target is not reachable directly from FortiPAM to proxy the connection to the target.

You can now add a gateway when configuring a target.

You can also add the gateway to a secret.

See:

- [Gateway on page 100](#)
- [Creating a gateway on the FortiPAM GUI on page 101](#)
- [Creating a target on page 93](#)
- [Creating a secret on page 60](#)
- [Creating a gateway on the FortiPAM CLI on page 102](#)
- [FortiPAM connects to a target through a FortiProxy acting as the gateway Example on page 104](#)

For troubleshooting, see [Troubleshooting network gateways on page 384](#).

968457- Display 2FA status

FortiPAM now displays the 2FA status for a user in the *Two-factor Authentication* column in *User Management > User List*. See [User list on page 216](#).

913565, 927433- Automated remote user provisioning

Before FortiPAM 1.3.0, all FortiPAM users were created manually by the administrator. Starting FortiPAM 1.3.0, FortiPAM allows you to automatically sync up users based on group membership without limiting the authentication protocol (LDAP, RADIUS, or SAML).

You can define a remote user auto provision rule in *User Management > Auto Provision Rules*.

Based on the predefined auto provision rules, remote users can be auto provisioned upon their first successful login without requiring the manual creation of a user in the system prior to login.

The auto provision rule includes information about the remote user group and users' role (access profile) on auto provision. The type of role depends on the user's group membership.

Based on the group, FortiPAM decides if the user can log in to FortiPAM and the type of permission the user is granted. Once the user logs in, the user is automatically created and listed in *User Management > User List*.

A new *Created By* column in *User List* tells you if the user was manually created or auto provisioned.

See [User list on page 216](#).

See [Auto provision rules on page 261](#).

To set up auto provisioning rule using the CLI, see [Setting up remote user auto provisioning using the CLI on page 265](#).

925187- Display ZTNA launch control inheritance settings for folders

When configuring permissions for a subfolder, in the *Permission* tab, with *Inherit ZTNA Control* enabled, ZTNA control settings from the parent folder are displayed. See [Creating a folder on page 110](#).

883603- vTPM support for FortiPAM on GCP

FortiPAM supports vTPM on GCP. See [Appendix K: Installation on GCP on page 451](#).

961527- Logs extracted as JSON and CSV file

FortiPAM allows you to extract log files in JSON and CSV formats in addition to exporting logs as text files.

A new *Export* dropdown is available in the following locations in *Log & Report*:

- All the tabs in *Secret*
- The *Details* tab in *Events*
- *ZTNA* tab
- *SSH* tab

- [Antivirus tab](#)
- [Data Leak Prevention tab](#)

See:

- [Secret on page 277](#)
- [Events on page 281](#)
- [ZTNA on page 284](#)
- [SSH on page 285](#)
- [Antivirus on page 287](#)
- [Date leak prevention on page 288](#)

913157, 959127- New Web Telnet launcher

A new *Web Telnet* secret launcher is available. See [Launchers on page 145](#).

957808- Password only viewable to the user checking out a secret

To ensure accountability, a secret password is only visible to the user with *Edit* or *Owner* permission for the secret the user is checking out.

Note that this is only valid when *Requires Checkout* is enabled in the *Secret Setting* pane when configuring the secret.

See [Check out and check in a secret on page 83](#).

839929- Import remote LDAP users

To conveniently import LDAP users in bulk on FortiPAM, a new *Import* option is available in *User Management > User List*.

See [Importing LDAP users on page 231](#).

878661- New remote server option when creating a remote user

When configuring a remote user, you are no more required to select a remote user group in the *User Type* pane. Instead, if the remote user does not belong to a remote user group, you can select the remote server where the user resides in the *Choose a Remote Group where these users can be found or a Remote Server* dropdown in the *User Type* pane.

See [Creating a user on page 218](#).

963099- Customizing replacement messages

A new *Replacement Messages* tab in *System* to customize replacement messages for FortiPAM.

See:

- [Replacement messages on page 359](#)
- [Replacement messages descriptions on page 361](#)

- [Editing a replacement message on page 362](#)
- [Managing images on page 364](#)
- [Insert an image to a replacement message](#)

975901, 963740- User deletion enhancements

You can delete users directly without deleting the references first.

If the deleted user alone owns resources not in the personal folder, e.g., secrets/folders in the public folder, targets, templates, user groups, or approved requests, etc., you can select a user who will own the resources once the user owning the resource is deleted.

See [User list on page 216](#).

A sponsor admin can delete members within its sponsored group.

See [Sponsored groups on page 240](#).

964873- Approver minimum permission

A new *Minimum Permission* dropdown when creating an approval profile in *Secret Settings > Approval Profile*.

You can set up the minimum secret permission required by the approver to view/approve/deny the secret request.

See [Create an approval profile on page 172](#).

920066- Approver group email notification for access requests

A new *Remote Group Email* option when creating an approval profile in *Secret Settings > Approval Profile*.



The option appears when you select at least one remote user group in *Approver Groups* when creating or editing an approval profile in *Secret Settings > Approval Profile*.

Enabling *Remote Group Email* ensures that members of an approver group receive email notification when an access request is sent for a secret where *Requires Approval to Launch Secret* is enabled and an approval profile is selected with at least one remote user group as an approver.

When *Remote Group Email* is enabled, a new *Trust Time* field appears. The *Trust Time* field controls how frequently the remote user needs to log in to FortiPAM to receive the approver email notification.

For example, when *Trust Time* is 5, a remote user belonging to the remote user group selected in *Approver Groups* must have logged in to FortiPAM at least once within five days from the access request creation time to receive the approver email notification.

See [Create an approval profile on page 172](#).

993481- Sync sender name across all emails

A new *Sender* field in the *Email Service* pane in *System > Settings*.

The *Sender* email address is the email address used to send emails.

See [Settings](#) on page 324 and [How FortiPAM chooses the sender email address](#) on page 331.

942734- Log and video disk encryption

FortiPAM supports disk encryption to protect logs and videos.

A new *Disk Encryption* option in *Log & Report > Log Settings*.

See [Log settings](#) on page 295.

964619- Immediate secret access on approval

When creating a secret access request in *Secrets > My Requests List* or directly from a secret in *Secrets > Secret List*, you can enable the *Start Upon Approval* option.

Enabling the *Start Upon Approval* option ensures that you can launch the secret once it is approved.

When *Start Upon Approval* is enabled, you see a new *Duration* option instead of the *Request Duration* option.

In the *Duration* option, specify the duration of time you need the secret access for (in minutes).

Note that the approver can still override when you get access to the secret and the duration of time you have access to the secret.

See [Make a request](#) on page 117.

954620, 997420- Adjust the timezone for the secret access requestor and approver

When creating a secret access request in *Secrets > My Request List*, FortiPAM shows the local time of the requestor in the *New secret request* window.

When approving/denying a secret access request in *Secrets > Approval List*, time according to the approver's timezone is displayed by default in the *Approving secret request* window.

By clicking the *Enable Requestor Timezone* option, you can enable the requestor's timezone and display the requestor's local time in the *Approving secret request* window.

New *Enable/Disable Requestor Timezone* option and *Timezone* column in *Secrets > Approval List*.

See:

- [Make a request](#) on page 117
- [Approving a request](#) on page 121
- [Approval list](#) on page 119

877089- Secret list displays secret creation time

Secret List in *Secrets* includes a new *Creation Time* column that displays when a secret was created.

See [Secret list](#) on page 58.

955024- Customize Email template for secret request

FortiPAM allows you to customize email templates for secret requests in *Secret Settings > Approval Email Template*.

See [Approval email template on page 175](#).

When creating a new approval profile in *Secret Settings > Approval Profile*, you can assign a customized email template to the approval profile using the new *Customized Email Template* option.

See [Create an approval profile on page 172](#).

950516- RDP auto token for FortiAuthenticator

FortiPAM supports RDP 2FA auto delivery when the FortiAuthenticator agent is running on remote Windows.

A new *RDP Auto TOTP* option available when *RDP Service* is enabled and the *RDP Security Level* is *TLS* in the *Service Setting* tab when creating or editing a secret in *Secrets > Secret List*.

See [Creating a secret on page 60](#).

A new *RDP Auto TOTP* option available when the *RDP Security Level* is *TLS* when creating or editing a secret policy in *Secret Settings > Policies*.

See [Creating a policy on page 157](#).

840054- Auto discovery of secrets

FortiPAM scans an environment to find accounts and other associated resources. Once the accounts and the resources are found, they can be automatically imported to FortiPAM for centralized management.

See [Discovery on page 126](#).

A new *Secret Discovery* option in the *Secret* tab when creating or editing a *Role* in *User Management > Role*.

See [Role on page 243](#).

893740- Increased secret capacity

FortiPAM can now support setting up a maximum of 50000 secrets in FortiPAM 1000G and up to 100000 in FortiPAM 3000G and the VM platform.

919801- Updating service account credentials

If a service running on a machine relies on a credential managed by FortiPAM, dependency updater feature offers the ability to update the service credential immediately after FortiPAM changes the credential. FortiPAM ensures that the service does not fail during authentication.

A new *Dependency Updater* tab in *Secret Settings*.

See [Dependency updater on page 166](#).

See [Updating a service account credential Example on page 168](#).

A new *Dependency* tab when creating or editing a secret.

It allows you to assign the secret to a target where the service defined in the selected dependency updater runs.

See [Creating a secret on page 60](#).

For information on service accounts, see [Service accounts on page 166](#).

987061- Updated secret logs and active sessions GUI

In *Log & Report > Secret*:

- A new *Service Account* page is available where you can view logs related to service accounts.

See [Service Account on page 281](#).

- In the *Secrets* and the *Password Changers* pages, the following new columns are available:

- *Secret Address*
- *Gateway*

Note that what the *Destination IP* column represents has changed. It is the next hop IP address. If the next hop is FortiPAM, this is the IP address of FortiPAM.

- If the next hop is the actual target server, this is the IP address of the actual target server.
- If the next hop is a gateway, this is the IP address of the gateway.

See [Secret on page 277](#).

In *Monitoring > Active Sessions*:

- The following new columns are available:

- *Gateway*
- *Gateway Port*
- *Gateway Name*

See [Active sessions on page 273](#).

Introduction

FortiPAM is a privileged access management solution. FortiPAM solutions are an important part of an enterprise network, providing role-based access, auditing, and security options for privileged users (users that have system access beyond that of a regular user).

FortiPAM delivers the following functionalities:

- **Credential vaulting:** Users do not need credentials, reducing the risk of credential leaking as no sensitive data is on the user system after a session. Passwords are automatically changed.
- **Privileged account access control:** Users can only access FortiPAM resources based on their roles (standard user or admin user).

FortiPAM offers secret permission control to access a target server. Admin users can define common policies and a hierarchical approval system for standard users to access sensitive information. FortiPAM also provides options to control risky user activities such as a user attempting to encrypt the disk.

FortiPAM offers ZTNA tag-based and protocol-based access control (RDP, SSH, VNC, and WEB) and allows access from anywhere, including native web-based access.

- **Privileged activity monitoring and recording:** FortiPAM can monitor, record, and audit privileged user activities. FortiPAM provides information on sessions, user keystrokes, and mouse events.



FortiPAM 1.3.1 requires FortiClient 7.2.3 or above to offer the full set of functionalities.

FortiPAM on a NAT internal network

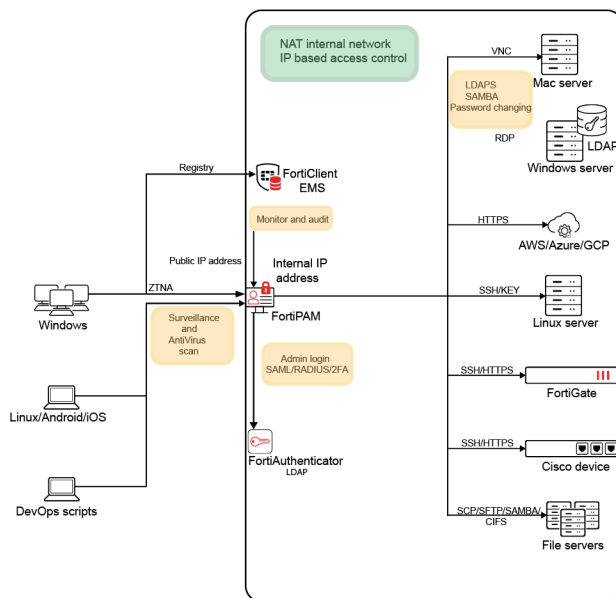

FortiPAM concepts

FortiPAM user

There are two types of FortiPAM user:

- Standard user: Performs management tasks on the target system, e.g., IT staff, IT contractor, Database Administrator (DBA). Standard users are typically IT Managers and IT System Admins.
- Admin user: Performs management tasks on FortiPAM server.

Target

A server/device with a privileged account supporting RDP, SSH, Web, or other admin protocols. Target systems include Windows workstation, Windows domain controller, Web server, Unix server, SQL- server, router, or firewall.

Targets allow a host to have common configuration across secrets.

Classification tags

Classification tags are used to categorize different targets by the OS type or location, e.g., Ubuntu, Windows AD, etc.

Secrets

The secrets contain information on login, credentials, and the target server IP address. Secrets are core assets in FortiPAM representing methods and credentials to access target systems in your organization.

Launchers

Launchers help users gain remote access to a target without needing to know, view, or copy the password stored in FortiPAM.

Launchers can invoke client-side software on the FortiPAM user's endpoint, which is software to perform management tasks, e.g., Internet Explorer, PuTTY(ssh), RDP client, and SQL-commander.

Folders

Folders help manage a large number of secrets efficiently by organizing them in a hierarchical view. You can organize customers, computers, regions, branch offices, etc., into folders.

You can quickly look for secrets from the folder tree view.

Granting permissions becomes faster as secrets in a folder share the same permission and policy.

Organization of the guide

The FortiPAM Administration Guide contains the following sections:

- [FortiPAM installation on page 35](#) describes basic setup information for getting started with your FortiPAM.
- [Licensing on page 41](#) describes how to register, download, and upload your FortiPAM-VM license.
- [Dashboard on page 47](#) contains widgets providing performance and status information.

- [Secrets on page 57](#) describes features and options related to secrets, targets, gateways, folders, secret and job requests, approval lists, jobs, and discovery.
- [Secret settings on page 133](#) describes features and options related to templates, launchers, policies, classification tags, addresses, dependency updaters, approval profiles, approval email templates, password changers and policies, character sets, antivirus, DLP, DLP file pattern, SSH filter profiles, event filter profile, and integrity check.
- [User management on page 216](#) describes managing FortiPAM user database.
- [Monitoring on page 273](#) contains information on user logins and active sessions on FortiPAM.
- [Log & report on page 277](#) describes how to view logs and reports on FortiPAM.
- [Network on page 308](#) describes configuring interfaces, static routes, DNS settings, fabric connectors, and packet capture.
- [System on page 324](#) describes managing and configuring basic system settings for FortiPAM. It also contains settings related to ZTNA, HA, certificates, replacement messages, SNMP, automatic backups, firmware, FortiPAM and FortiGuard licenses.

Using the GUI

This section presents an introduction to the graphical user interface (GUI) on your FortiPAM.

The following topics are included in this section:

- [Banner on page 19](#)
- [Tables on page 25](#)

For information about using the dashboards, see [Dashboard on page 47](#).

Banner

Along the top of each page, the following options are included in the banner:

- Open/close side menu
- *Search icon*: opens GUI based global search. See [GUI based global search on page 20](#).
- Build number



In the build number dropdown, select *Hide Label* to hide the build number.

- *CLI console* (☰): opens the CLI console. See [CLI commands on page 20](#).
- *Help* (📖): opens the online help document.
- *Notifications* (🔔): shows latest notifications.
- *Theme*: from the dropdown, select one of the available themes.
- *Admin*: from the dropdown, see FortiPAM version and build, go to system and configuration, change password, or log out. See [Admin on page 21](#).

GUI based global search

The global search option in the GUI allows users to search for keywords appearing in objects and navigation menus to quickly access the object and configuration page. Click the magnifying glass icon in the top-left corner of the banner to access the global search.

The global search includes the following features:

- Keep a history of frequent and recent searches
- Sort results alphabetically by increasing or decreasing order, and relevance by search weight
- Search by category
- Search in Security Fabric members (accessed by the Security Fabric members dropdown menu in the banner)

Global search example - Example

In this example, searching for the word ZTNA yields the following results:

- *ZTNA in System*
- *ZTNA in Log & Report*

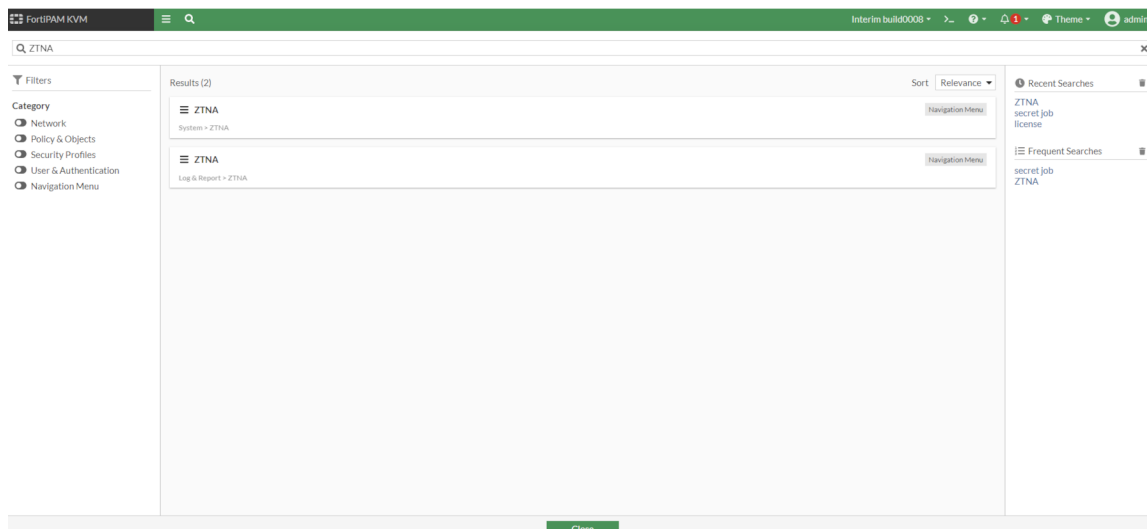

CLI commands

FortiPAM has CLI commands that are accessed using SSH, or through the CLI console if a FortiPAM is installed on a FortiHypervisor.

To open a CLI console, click the >_ icon in the top right corner of the GUI. The console opens on top of the GUI. It can be minimized and multiple consoles can be opened.



CLI commands can be used to initially configure the unit, perform a factory reset, or reset the values if the GUI is not accessible.



The FortiPAM-VM's console allows scrolling up and down through the CLI output by using `Shift+PageUp` and `Shift+PageDown`.

Like FortiOS, the `?` key can be used to display all possible options available to you, depending upon where you are hierarchically-situated.

Admin

The Admin dropdown contains the following information and options:

- FortiPAM build number and version.
- *System*: activate glass breaking mode, maintenance mode, reboot, shutdown, and upload a firmware.



The following actions can only be performed when FortiPAM is in maintenance mode:

- Reboot.
- Shutdown.
- Uploading a firmware. See [Uploading a firmware on page 22](#).
- Uploading a license. See [Licensing on page 41](#).
- Restoring a configuration. See [Backup and restore on page 23](#).

- *Configuration*: backup, restore, see configuration revisions, and run configuration scripts.
- *Change Password*: opens the *Edit Password* window where you can change the administrator password.



Only the super administrator can change a user password.

- *Logout*: log out of FortiPAM.

Glass Breaking mode

The glass breaking mode gives you access to all secrets in the system.

Glass breaking in FortiPAM means extending the user permission to access data that the user is not authorized to access. Typically, user access is controlled by permission defined in every secret and folder. In a rare situation, such as a network outage or the remote authentication server becoming unreachable, glass breaking allows you to temporarily access important secrets and target servers to resolve issues.

As a best practice, only a few administrators should have access to the glass breaking mode. Further, the glass breaking mode should only be activated under exceptional situations and for disaster recovery. Email notifications can also be configured to send alerts whenever someone enters glass breaking mode. See [Email alert when the glass breaking mode is activated example on page 303](#).

Under glass breaking mode, all administrator activities should be logged for future audits.



Only a user configured with glass breaking permission can activate the glass breaking mode. The permission is defined when configuring a user role in *User Management > Role*. See [Role on page 243](#).



When an administrator activates glass breaking mode on FortiPAM, the administrator can bypass normal access control procedures, get access to all folders, secrets (including the password clear text), and secret requests, and launch any secret.

To enter glass breaking mode:

1. From the user dropdown on the top-right, select *Activate Glass Breaking Mode* in *System*.
2. Enter a reason for activating the glass breaking mode.
3. Click *OK*.
The GUI is refreshed, and a red banner is shown on the top: *FortiPAM is in glass breaking mode*.

To deactivate glass breaking mode:

1. From the user dropdown on the top-right, select *Deactivate Glass Breaking Mode* in *System* to deactivate the glass breaking mode.
The GUI is refreshed, and a message appears on the bottom-right: *Successfully demoted user*.

When you are in the glass breaking mode, FortiPAM enforces video recording on launching a session.

To disable video recordings when in glass breaking mode:

1. Go to *System > Settings*.
2. In the *PAM Settings* pane, disable *Enforce recording on glass breaking*.
3. Click *Apply*.

Activate maintenance mode

Suspend all critical processes to allow maintenance related activities.

Uploading a firmware

You can only upload a firmware when in maintenance mode.

To enter maintenance mode:

1. From the user dropdown, select *Activate Maintenance Mode* in *System*.
2. In the *Warning* dialog:
 - a. Enter the maximum duration, in minutes.
 - b. Enter a reason for activating the maintenance mode.
 - c. Click *OK*.



When in maintenance mode, select *Renew Maintenance Mode* in *System*, enter the new duration and reason and then click *OK* to renew the maintenance mode.



When in maintenance mode, select *Deactivate Maintenance Mode* in *System* to deactivate the maintenance mode.

To upload a firmware:

1. In the user dropdown, go to *System > Firmware*.

The *Firmware Management* window opens.

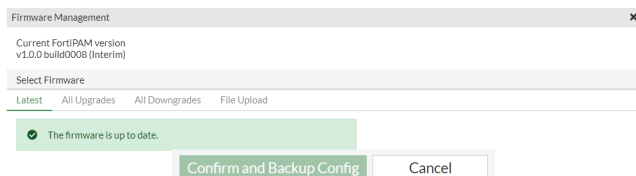

The following options are available:

Latest	Displays the status of the current firmware.
All Upgrades	Displays if new upgrades are available.
All Downgrades	Displays if downgrades are available.
File Upload	Allows you to upload a new firmware image manually.

2. Go to *File Upload*:

- a. Select *Browse*, then locate the firmware image on your local computer.
- b. Click *Open*.

3. Click *Confirm and Backup Config*.

The firmware image uploads from your local computer to the FortiPAM device, which will then reboot. For a short period of time during this reboot, the FortiPAM device is offline and unavailable.

Backup and restore

Fortinet recommends that you back up your FortiPAM configuration to your management computer on a regular basis to ensure that, should the system fail, you can quickly get the system back to its original state with minimal effect to the network. You should also perform a back up after making any changes to the FortiPAM configuration.

You can encrypt the backup file to prevent tampering.

You can perform backups manually. Fortinet recommends backing up all configuration settings from your FortiPAM unit before upgrading the FortiPAM firmware.

Your FortiPAM configuration can also be restored from a backup file on your management computer.

To backup FortiPAM configuration:

1. In the user dropdown, go to *Configuration > Backup*.
The *Backup System Configuration* window opens.
2. Select *Local PC* as the backup option.
3. Enable *Encryption*, enter and confirm password.

4. Click *OK*.
The backup file is downloaded to your local computer.

To restore FortiPAM configuration:

1. Enter maintenance mode. See [Maintenance mode](#).
2. In the user dropdown, go to *Configuration > Restore*.
The *Restore System Configuration* window opens.
3. Select *Local PC* as the option to restore from.
4. Select *Upload*:
 - a. Locate the backup file on your local computer.
 - b. Click *Open*.
5. In *Password*, enter the encryption password.
6. Click *OK*.
When you restore the configuration from a backup file, any information changed since the backup will be lost. Any active sessions will be ended and must be restarted. You will have to log back in when the system reboots.

Revisions

You can manage multiple versions of configuration files on FortiPAM.

Configurations scripts

Configuration scripts are text files that contain CLI command sequences. They can be created using a text editor or copied from a CLI console, either manually or using the Record CLI Script function.

Scripts can be used to run the same task on multiple devices.



A comment line in a script starts with the number sign (#). Comments are not executed.

To run a script using the GUI:

1. In the user dropdown, go to *Configuration > Scripts*.
2. Select *Run Script*.
3. In the *Run Script* window:
 - a. Select either *Local* or *Remote* as the *Source*.
 - b. Select *Browse*, then locate the script on your local computer.
 - c. Click *Open*.
4. Click *OK*.
The script runs immediately, and the table is updated, showing if the script ran successfully.

Tables

Many GUI pages contain tables of information that can be filtered and customized to display specific information in a specific way.

Some tables allow content to be edited directly on that table.

Navigation

Some tables contain information and lists that span multiple pages.

Navigation controls are available at the bottom of the page.

Filters

Filters are used to locate a specific set of information or content in a table. They can be particularly useful for locating specific log entries. The filtering options vary, depending on the type of information in the log.

Depending on the table content, filters can be applied using the filter bar, using a column filter, or based on a cell's content. Some tables allow filtering based on regular expressions.

Administrators with read and write access can define filters. Multiple filters can be applied at one time.

To create a column filter:

1. When available on a GUI page, select + in the search bar.

Name	Address	Description	Auto Password Changing	Last Launch Time	Last Password Change	Last Password Verification	Folder	Template	Creation Time
Windows	207		disabled	2023/10/18 12:14:09	Never changed	Success at 2023-07-31 17:20:33	Public Folder	Windows Machine	
Cisco	20		disabled	2023/10/24 11:37:00	Never changed	Success at 2023-09-27 16:49:10	Public Folder	Cisco User (SSH Secret)	
SVR_100	102		disabled	2023/11/02 15:49:29	Never changed	Success at 2023-10-31 16:29:12	Public Folder	Unix Account (SSH Key)	
ssh	101		disabled	2024/01/17 10:11:14	Never changed	Success at 2023-11-28 16:12:14	admin	Unix Account (SSH Password)	
SQL-ssh	103		disabled	2023/10/30 11:00:58	Success at 2023-12-01 14:15:38	Success at 2023-12-01 14:15:34	admin	Unix Account (SSH Password)	
SVR_100	200		disabled	2023/11/27 13:35:01	Success at 2024-01-20 15:57:57	Success at 2024-01-20 15:35:18	Public Folder	Linux_Key_Template	
Windows	103		disabled	2023/11/15 14:40:22	Success at 2024-01-20 16:03:36	Success at 2024-01-20 15:36:56	Public Folder	Windows Domain Account	
SVR_100	103		enabled	2023/11/02 15:50:24	Success at 2024-02-07 15:44:33	Success at 2024-01-20 15:41:01	Public Folder	Unix Account (SSH Password)	2024/01/25 15:46:18
SVR_101	01		enabled	2024/01/04 09:56:06	Success at 2024-02-07 15:36:31	Success at 2024-02-02 11:28:10	Public Folder	Linux_Template	2024/01/25 15:37:18
API_ZTN4	15		disabled	Never launched	Never changed	Never verified	ztna_test_folder	Unix Account (SSH Password)	
AW5			disabled	2023/11/17 18:42:03	Never changed	Never verified	admin	Web Account	
Azure			disabled	2023/12/29 16:30:16	Never changed	Never verified	Public Folder	Web Account	
Dell_IDrac			disabled	2024/01/15 13:59:27	Never changed	Never verified	Public Folder	Web Account	
ESX1_3			disabled	2023/11/02 16:57:34	Never changed	Never verified	Public Folder	Web Account	
ESX1_3_New			disabled	Never launched	Never changed	Never verified	Public Folder	Target Only	
FAC_Web			disabled	2023/11/15 14:49:14	Never changed	Never verified	Public Folder	Web Account	
FOU_Test			disabled	2023/10/17 15:56:03	Never changed	Never verified	Public Folder	Web Account	
GCP			disabled	2023/12/29 16:31:04	Never changed	Never verified	admin	Web Account	
heidi			disabled	2023/10/24 16:02:16	Never changed	Never verified	Public Folder	HeidiSQL	
Hotmail_2			disabled	2023/10/30 12:13:10	Never changed	Never verified	admin	Web Account	
HTTP_254			disabled	2023/11/02 16:34:05	Never changed	Never verified	Public Folder	Web Account	
Mac_Mini			disabled	2023/11/02 15:51:28	Never changed	Never verified	Public Folder	Machine	
Mini-MAC			disabled	2023/11/02 15:51:47	Never changed	Never verified	Public Folder	Machine	
RDP			enabled	2023/06/20 16:01:44	Failure at 2024-02-01 10:59:04	Never verified	Public Folder	Windows Machine	
SQL			disabled	2023/11/07 12:03:30	Never changed	Never verified	admin	SQL Server	
SQL-azure			disabled	2023/11/02 12:12:14	Never changed	Never verified	admin	SQL Server	
SQL-azure-default			disabled	2023/10/27 08:56:02	Never changed	Never verified	admin	Database Server	
SQL-copy			disabled	2023/10/24 16:00:38	Never changed	Never verified	admin	HeidiSQL_Template	

Alternatively, select the *Filter/Configure Column* (⌵) icon when you hover on the right of the column header, and skip to step 3.

Name	Target Address	Description	Auto Password Changing	Last Launch Time	Last Password Change	Last Password Verification	Folder	Template	Creation Time
Windows_11			Disabled	2023/10/18 12:14:09	Never changed	Success at 2023-07-31 17:20:33	Public_Folder	Windows Machine	
Cisco			Disabled	2023/10/24 11:37:00	Never changed	Success at 2023-09-27 16:49:10	Public_Folder	Cisco User (SSH Secret)	
SVR_102_14			Disabled	2023/11/02 15:49:29	Never changed	Success at 2023-10-31 16:29:12	Public_Folder	Unix Account (SSH Key)	
ssh			Disabled	2024/01/17 10:11:14	Never changed	Success at 2023-11-28 16:12:14	admin	Unix Account (SSH Password)	
SQL_ssh			Disabled	2023/10/30 11:00:56	Success at 2023-12-01 14:15:38	Success at 2023-12-01 14:15:54	admin	Unix Account (SSH Password)	
SVR_102			Disabled	2023/11/27 13:35:01	Success at 2024-01-20 15:57:57	Success at 2024-01-20 15:35:18	Public_Folder	Linux_Key_Template	
Windows_AD			Disabled	2023/11/15 14:40:22	Success at 2024-01-20 16:03:56	Success at 2024-01-20 15:36:56	Public_Folder	Windows Domain Account	
SVR_103			Enabled	2023/11/02 15:50:24	Success at 2024-02-07 15:44:33	Success at 2024-01-20 15:41:01	Public_Folder	Unix Account (SSH Password)	2024/01/25 15:46:18
SVR_101			Enabled	2024/01/04 09:56:06	Success at 2024-02-07 15:36:31	Success at 2024-02-02 11:28:10	Public_Folder	Linux_Template	2024/01/25 15:37:18
API_2THA_TEST			Disabled	Never launched	Never changed	Never verified	ztrna_test_folder	Unix Account (SSH Password)	
AWS			Disabled	2023/11/17 18:42:03	Never changed	Never verified	admin	Web Account	
Azure			Disabled	2023/12/29 16:30:16	Never changed	Never verified	Public_Folder	Web Account	
Dell_Drac			Disabled	2024/01/15 13:59:27	Never changed	Never verified	Public_Folder	Web Account	
ESXi_3			Disabled	2023/11/02 16:57:34	Never changed	Never verified	Public_Folder	Web Account	
ESXi_3_New			Disabled	Never launched	Never changed	Never verified	Public_Folder	Target Only	
FAC_Web			Disabled	2023/11/15 14:49:14	Never changed	Never verified	Public_Folder	Web Account	
FOS_Test			Disabled	2023/10/17 15:56:03	Never changed	Never verified	Public_Folder	Web Account	
GCP			Disabled	2023/12/29 16:31:04	Never changed	Never verified	admin	Web Account	
heidi			Disabled	2023/10/24 16:02:16	Never changed	Never verified	Public_Folder	HeidiSQL	
Hotmail_2			Disabled	2023/10/30 12:13:10	Never changed	Never verified	admin	Web Account	
HTTP_254			Disabled	2023/11/02 16:34:05	Never changed	Never verified	Public_Folder	Web Account	
Mac_Mini			Disabled	2023/11/02 15:51:28	Never changed	Never verified	Public_Folder	Machine	
Mini-MAC			Disabled	2023/11/02 15:51:47	Never changed	Never verified	Public_Folder	Machine	
RDP			Enabled	2023/06/20 16:01:44	Failure at 2024-02-01 10:59:04	Never verified	Public_Folder	Windows Machine	
SQL			Disabled	2023/11/07 12:03:20	Never changed	Never verified	admin	SQL Server	
SQL-azure			Disabled	2023/11/02 12:12:14	Never changed	Never verified	admin	SQL Server	
SQL-azure-default			Disabled	2023/10/27 08:56:02	Never changed	Never verified	admin	Database Server	
SQL-copy			Disabled	2023/10/24 16:00:38	Never changed	Never verified	admin	HeidiSQL Template	
SQL-video recording			Disabled	2023/06/02 18:44:30	Never changed	Never verified	admin	Microsoft SQL server	



When importing users as shown in [Importing LDAP users on page 231](#), the *Filter/Configure Column* (⌵) icon is available next to *All Users*.

2. Select one of the columns as a filter.
3. In the window that opens, you can set combinations of *Contains*, *Exact Match*, and *NOT*.

The screenshot shows the 'Filter/Configure Column' dialog box. It has a 'Filter' dropdown menu with options: 'Contains', 'Exact Match', and 'NOT'. Below the dropdown is a search input field containing 'value1, value2, etc.'. There are also 'Suggestions' listed below the input field. An 'Apply' button is at the bottom of the dialog.

When importing users as shown in [Importing LDAP users on page 231](#), the following options are available for *All Users* and *Group*:

- *Contains*
- *End With*
- *Exact Match*
- *None*
- *Start With*



New User List

Configure Role User Import Review

Choose Remote Users

Remote Server: Windows200

All Users	Filter	Mail ID
<input checked="" type="checkbox"/> auto_pam	Custom	
<input checked="" type="checkbox"/> auto_pam	Category	
<input checked="" type="checkbox"/> auto_pam	All Users Group	
<input checked="" type="checkbox"/> auto_pam	Filter	
<input checked="" type="checkbox"/> ed_test	Contains	auto_pam_1@fortipam.ca
<input checked="" type="checkbox"/> frank_admin	End With	auto_pam_2@fortipam.ca
<input checked="" type="checkbox"/> frank_admin	Exact Match	
<input checked="" type="checkbox"/> frank_admin	None	
<input checked="" type="checkbox"/> frank_admin	Start With	
<input type="checkbox"/> frank_test		
<input type="checkbox"/> iwen_admin		
<input checked="" type="checkbox"/> iwen_admin		iwen@fortipam.ca
<input type="checkbox"/> james_st		
<input type="checkbox"/> james1		

Selected Users

sAMAccountName	Mail ID
No results	

0% 731

Previous Next Cancel

You can also create a custom filter by enabling *Custom* and setting up a filter:

New User List

Configure Role User Import Review

Choose Remote Users

Remote Server: Windows200

All Users	Filter	Mail ID
<input checked="" type="checkbox"/> auto_pam	Custom	
<input checked="" type="checkbox"/> auto_pam	Category	
<input checked="" type="checkbox"/> auto_pam	All Users Group	
<input checked="" type="checkbox"/> auto_pam	Filter	
<input checked="" type="checkbox"/> ed_test	{objectCategory=person objectClass=st	
<input checked="" type="checkbox"/> frank_admin		
<input checked="" type="checkbox"/> frank_admin		
<input checked="" type="checkbox"/> frank_admin		
<input checked="" type="checkbox"/> frank_admin		
<input type="checkbox"/> frank_test		
<input type="checkbox"/> iwen_admin		
<input checked="" type="checkbox"/> iwen_admin		iwen@fortipam.ca
<input type="checkbox"/> james_st		
<input type="checkbox"/> james1		

Selected Users

sAMAccountName	Mail ID
No results	

0% 731

Previous Next Cancel

In the *Replacement Message* page, the following options are available:

- *Contains*
- *Does Not Contain*
- *Regex*

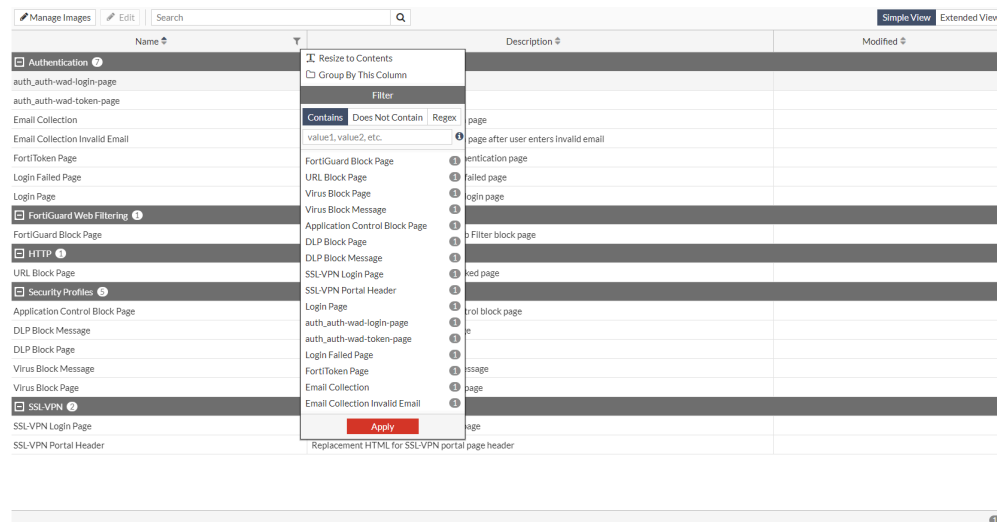

4. Either enter a term or terms separated by " , " or | , or select from the list that appears.
5. Click *Apply*.



You can combine multiple filters by selecting + and repeating steps 2 to 5 for every new filter that you require.

Alternatively, select *Filter/Configure Column* on the right of the column header, and repeat steps 3 to 5 for every new filter that you require.

Column settings

Columns can be rearranged, resized, and added or removed from tables.

To add or remove columns:

1. Right-click a column header, or click the gear icon on the left side of the header row that appears when hovering the cursor over the headers.
2. Select columns to add or remove.
3. Click *Apply*.

To rearrange a columns in a table:

1. Click and drag the column header.

To resize a column to fit its contents:

1. Select *Filter/Configure Column* from the column header.
2. In the window that opens, select *Resize to Contents*.

3. Click *Apply*.

To group contents by a column:

1. Select *Filter/Configure Column* from the column header.
2. In the window that appears, select *Group By This Column*.
3. Click *Apply*.

To resize all of the columns in a table to fit their content:

1. Right a column header, or click the gear icon on the left side of the header row that appears when hovering the cursor over the headers.
2. Click *Best Fit All Columns*.

To reset a table to its default view:

1. Right-click a column header, or click the gear icon on the left side of the header row that appears when hovering the cursor over the headers.
2. Click *Reset Table*.



Resetting a table removes applied filters.

To arrange contents in a column by ascending or descending order:

1. Click the up or down arrow to arrange contents in a column by ascending or descending order respectively.

To select multiple entries in a table:

1. Select the first entry.
2. Press and hold `ctrl`, select the second item, and so on.

Modes of operation

FortiPAM can operate in the following two modes:

- **Proxy:** All the launched traffic to the target server is forwarded to FortiPAM first. FortiPAM then connects to the target server. FortiPAM delivers fake credentials to the client machine. FortiPAM manages the credentials and login procedures to the target server.

All the traffic except web browsing is proxied through FortiPAM.



The proxy mode is more secure than the non-proxy mode as it does not deliver sensitive information to the client machine.

In the proxy mode, the administrator can terminate traffic connections if improper user behavior is detected.

Web SSH, Web RDP, Web VNC, Web SFTP, and Web SMB default launchers always use the proxy mode irrespective of the proxy settings.

- **Non-proxy:** All the launched traffic is directly connected to the target server without FortiPAM. FortiPAM delivers the credential information to the client machine. The native program, PuTTY or the website browser directly connects to the server.



The direct connection (non-proxy) mode or the web browsing comes with an added risk of credential leakage. To reduce such risks, this mode is strictly controlled by user permissions.

Users without sufficient permission cannot access direct mode or web browsing launchers.

The following features do not work when FortiPAM is in non-proxy mode:

- SSH filters
- SSH auto password delivery
- Block RDP clipboard
- RDP security level

PuTTY and WinSCP launchers are not supported when the secret is in non-proxy mode, and the secret uses an SSH key for authentication.

TightVNC launcher is not supported when the secret is in non-proxy mode and requires a username for authentication.

When using launchers with non-proxy mode, launchers may require the environment to be initialized beforehand. You may specify this with `init-commands` and `clean-commands`.

Note: `init-commands` and `clean-commands` only run in the non-proxy mode.



To select the mode of operation, see the *Proxy Mode* option when creating or editing a secret. See [Creating a secret on page 60](#). Alternatively, see the *Proxy Mode* option when creating or editing a policy. See [Creating a policy on page 157](#).

FortiPAM deployment options

A full FortiPAM solution involves FortiPAM, EMS, and standard FortiClient. When both FortiPAM and FortiClient register to EMS, ZTNA endpoint control is available for secret launching and FortiPAM server access control. Both FortiPAM and the target server is protected by the highest security level.

When EMS is not available, standalone FortiClient is recommended. With standalone FortiClient, native launchers such as PuTTY, RDP, VNC Viewer, Tight VNC, and WinSCP can be used to connect to the target server and user can take advantage of functionalities provided by these applications. Also, video recording for user activity on the target server is sent to FortiPAM in real-time.

For information on installing FortiPAM browser extension and standalone FortiClient on an air-gapped computer, see [Appendix M: FortiPAM browser extension and standalone FortiClient air-gapped installation on page 471](#).

For information about the over-the-shoulder monitoring (live recording) feature, see [Over-the-shoulder monitoring \(Live recording\) on page 275](#).

If FortiClient is not available, e.g., a user with Linux or MacOS system, Chrome and Edge extension called *Fortinet Privileged Access Agent* is available on [Chrome Web Store](#) and [Microsoft Edge Add-ons](#). On this extension-only setup, web-based launchers and web browsing are supported. The extension can record user activities on the target server.

On a system without FortiClient and browser extension, the user can still log in to FortiPAM and use the web-based launchers. However, all other features mentioned above are not available.

1. If EMS (7.2.0 or later) is available:

a. EMS Server:

- i. Enable *Privilege Access Management*-
 - i. Navigate to *Endpoint Profiles > System Settings*.
 - ii. Edit the *Default System Setting Profiles*.
 - iii. Select *Advanced* and enable *Privilege Access Management*.
 - iv. In *Port*, enter 9191.
 - v. Click *Save*.

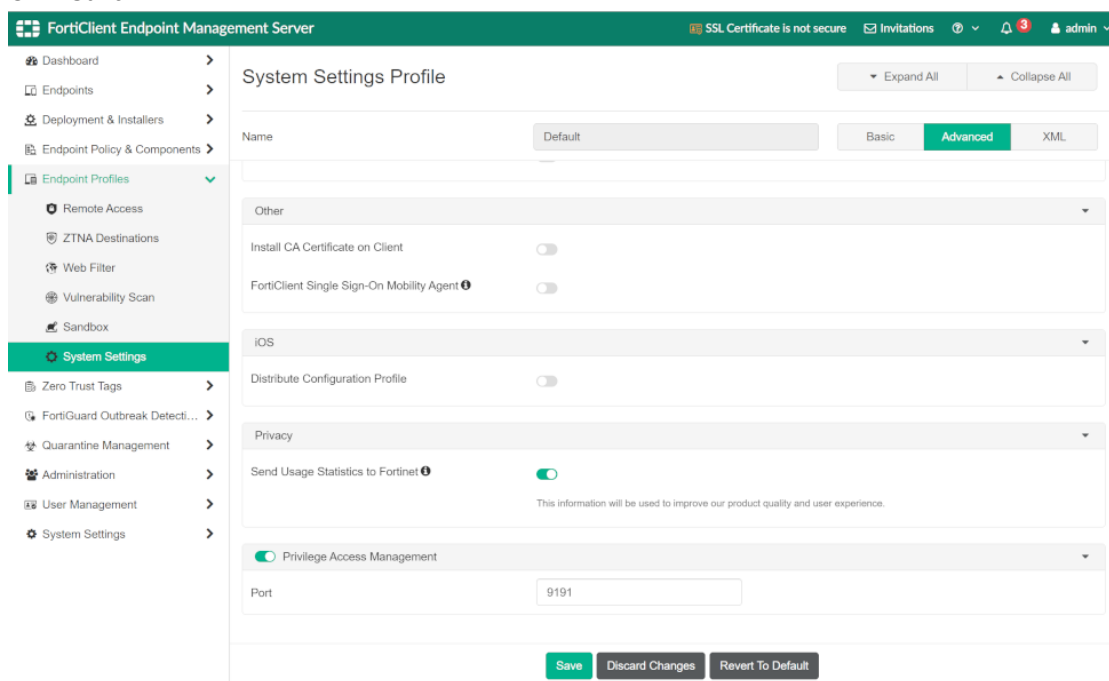

- ii. Push FortiClient (7.2.0 or later) to registered PC-
 - i. Navigate to *Deployment & Installers > FortiClient Installer*.
 - ii. Add a package with both *Zero Trust Network Access* and *Privilege Access Management* enabled on the third tab of the wizard.

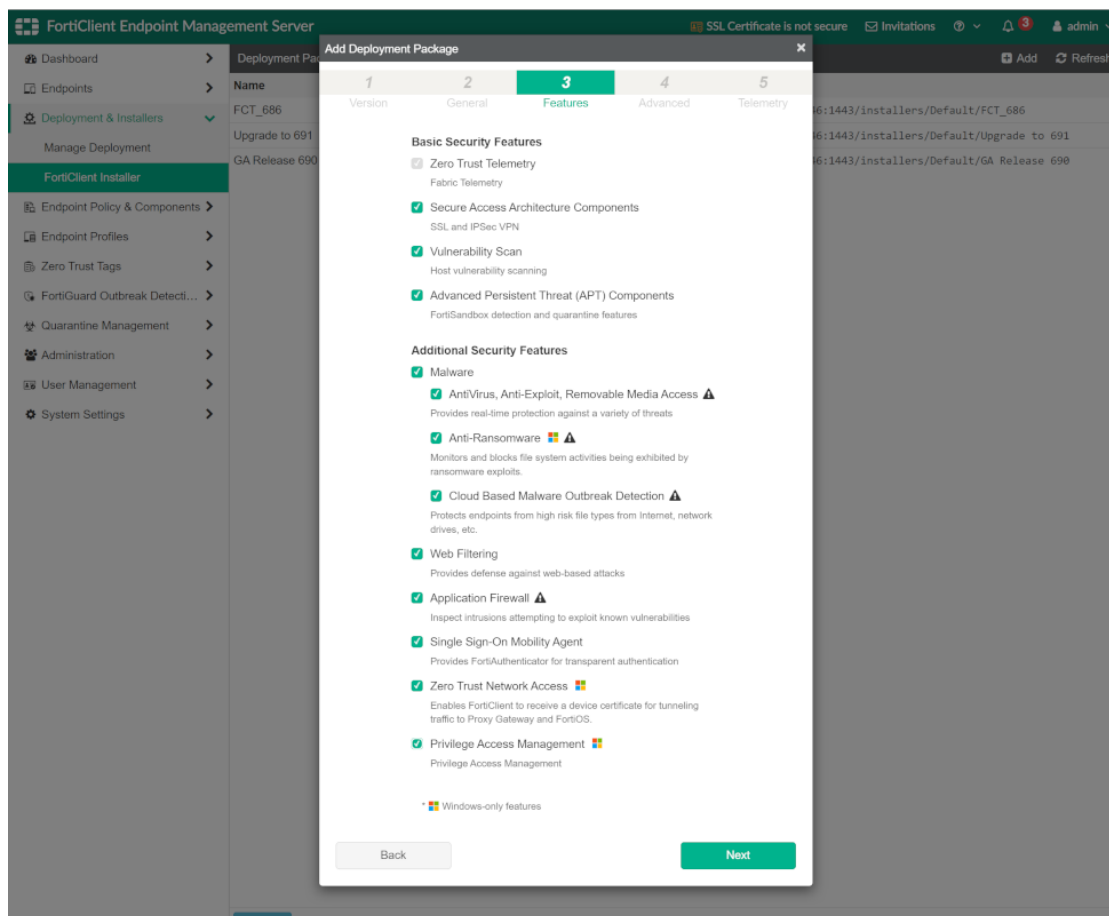

- iii. Navigate to *Deployment & Installers* > *Manage Deployment* and apply the FortiClient installer package to select endpoint groups.
 - b. **Windows:** Download standard FortiClient (7.2.0 or later), and enable "ZTNA" and "PAM" functions during the installation. Full FortiPAM features are then supported.
After FortiClient registers to EMS, EMS can automatically deploy the configured FortiClient version to Windows PC.
 - c. **Linux and MacOS:** Install *Fortinet Privileged Access Agent* extension from the Chrome Web Store or follow the FortiPAM GUI prompt. Then use web-based launchers or web launcher to access the target server.
Note: ZTNA and Native launchers are not supported on extension-only systems.
2. If EMS (7.2.0 or later) is not available:
 - a. **Windows:** After downloading and installing standalone FortiClient (7.2.0 or later) manually, most PAM features are supported.
Note: A standalone installer contains PAM in its filename such as `FortiClientPAMSetup_7.2.0.0xxx_x64.exe`.
Note: ZTNA is not supported.
 - b. **Linux and MacOS:** Install *Fortinet Privileged Access Agent* extension from the Chrome Web Store or follow the FortiPAM GUI prompt. Then use web-based launchers or web launcher to access the target server.
Note: ZTNA and Native launchers are not supported on extension-only systems.
3. If FortiClient is not available (extension-only):
 - a. **Windows:** Install *Fortinet Privileged Access Agent* extension from the Chrome Web Store or Microsoft Edge Add-ons. Then use web-based launchers or web launcher to access the target server.
Note: ZTNA and Native launchers are not supported on extension-only systems.

- b. Linux and MacOS:** Install *Fortinet Privileged Access Agent* extension from the Chrome Web Store or follow the FortiPAM GUI prompt. Then use web-based launchers or web launcher to access the target server.

Note: ZTNA and Native launchers are not supported on extension-only systems.

Note: Chrome or Edge web browsers are suggested for use as there is some limitation on Firefox extension-only deployment.

Feature availability

The following table lists FortiPAM 1.3.1 feature availability based on the type of deployment being used:

Feature	FortiPAM with standard FortiClient	FortiPAM with standalone FortiClient	FortiPAM with browser extension	FortiPAM only
Windows OS	✓	✓	✓	✓
Linux OS	X	X	✓	✓
MacOS	X	X	✓	✓
ZTNA	✓	X	X	X
Web-based launchers, i.e, Web-SSH, Web-RDP, Web-VNC, Web-SFTP, and Web-SMB (only supports proxy mode; credential protected in FortiPAM)	✓	✓	✓	✓
Proxy mode web browsing (credential sent to the extension with permission protection)	✓	✓	✓	X
Direct mode web browsing (credential sent to the extension with permission protection)	✓	✓	✓	X
Video recording	✓	✓	✓	X
Instant video uploading	✓	✓	✓	X

Feature	FortiPAM with standard FortiClient	FortiPAM with standalone FortiClient	FortiPAM with browser extension	FortiPAM only
Proxy mode native launchers, i.e., PuTTY, RDP, VNC Viewer, Tight VNC, and WinSCP (credential protected in FortiPAM)	✓	✓	X	X
Direct mode native launchers, i.e., PuTTY, RDP, VNC Viewer, Tight VNC, and WinSCP (credential delivered to FortiClient with permission protection)	✓	✓	X	X

FortiPAM installation

This chapter provides basic setup information for getting started with your FortiPAM.



FortiPAM is a server-side machine. FortiClient is required to be installed on the client side to use the native program on Windows.

The following virtualization environments are supported by FortiPAM 1.3.1:

- VMware ESXi/ ESX 6.5 and above
- KVM
- Microsoft Hyper-V
- Microsoft Azure
- GCP (Google Cloud Platform)
- AWS (Amazon Web Services)

FortiPAM supports both Linux and Windows environments.



On Windows, the user may install FortiClient which includes fortivr as a recording daemon, fortitcs as ZTNA daemon and a chrome extension. With FortiClient installed, the privileged activity recording can be supported. Without it, only web mode can be supported.

See [Installing FortiClient with the FortiPAM feature](#) on page 35 and [FortiPAM appliance setup](#) on page 36.

Installing FortiClient with the FortiPAM feature

To install FortiClient:

1. Install Google Chrome web browser.
2. Install FortiClient on your endpoint system.

See the *FortiClient Administration Guide* on the [Fortinet Docs Library](#).

Ensure that the ZTNA and PAM features are enabled during installation.

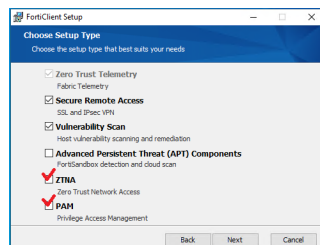

Ensure that no other FortiClient version is installed. If another FortiClient version has already been installed, it should first be uninstalled before installing the FortiPAM version. See [Uninstalling FortiClient](#).

3. Reboot the PC.



Chrome, Firefox, and Edge can automatically install *Fortinet Privileged Access Agent* in addition to fortivr and fortitcs daemons.

Uninstalling FortiClient

To uninstall FortiClient:

1. Disconnect the FortiClient from EMS.
2. From the *System Tray*, right-click FortiClient, and select shutdown FortiClient.
3. Uninstall FortiClient.
4. Reboot the PC.

FortiPAM appliance setup

Before using FortiPAM-VM, you need to install the KVM or the VMware application to host the FortiPAM-VM device. The installation instructions for FortiPAM-VM assume you are familiar with KVM or the VMware products and terminology.

FortiPAM-VM image installation and initial setup

See [Appendix A: Installation on KVM on page 398](#).

See [Appendix B: Installation on VMware on page 401](#).

See [Appendix F: Installation on Hyper-V on page 411](#).

See [Appendix G: Installation on Azure on page 422](#).

See [Appendix J: Installation on AWS on page 438](#).

See [Appendix K: Installation on GCP on page 451](#).

After FortiPAM is installed, FortiPAM listens using the following default ports:

- **HTTPS GUI:** 443
- **Web proxy:** 8080
(If web proxy is enabled)



Ensure that ports 443 and 8080 are open if using a firewall before FortiPAM.

Once FortiPAM-VM is powered on:

1. At the login prompt, enter `admin` and hit *Enter*.
By default, there is no password, however, a password must be set before you can proceed. Enter and confirm the new administrator password.
2. At the CLI prompt, enter `show system storage` to verify the disk usage type for the two added hard disks. The output looks like the following:



Administrators need to configure a dedicated FortiPAM video disk for video recording.



Two hard disks and two virtual network interface cards need to be added to the VM in VM manager before FortiPAM image installation.

See [Appendix A: Installation on KVM on page 398](#).

```
config system storage
  edit "HD1"
    set status enable
    set media-status enable
    set order 1
    set partition "LOGUSEDXDE8326F6"
    set device "/dev/vda1"
    set size 20023
    set usage log
  next
  edit "HD2"
    set status enable
    set media-status enable
    set order 2
    set partition "PAMVIDEOB471724F"
    set device "/dev/vdb1"
    set size 20029
    set usage video
  next
end
```

3. Enter the following CLI commands to set up FortiPAM:

```
config system interface
  edit "port1"
    set ip 172.16.x.x/x #Depending on your network setting
    set type physical
    set snmp-index 1
  next
  edit "port2"
    set ip x.x.x.x/x
    set type physical
    set snmp-index 2
  next
end
config router static
  edit 1
    set gateway x.x.x.x
    set device "port1"
  next
end
```

When upgrading a FortiPAM instance, use the following CLI command to enable synchronizing the virtual IP address to the IP address of the external interface:

Example



```
config firewall vip
  set intf-ip-sync enable
  set extintf "port1" #The interface connected to the source network
  #The interface connected to the source network that receives the packets
  #forwarded to the destination network.
end
```

When installing a new FortiPAM instance, the synchronization happens automatically.

4. Optionally, enable TPM or vTPM. See [FortiPAM with TPM on page 38](#).
5. Optionally, to encrypt disk to protect logs and videos, see [Configuring log and video disk encryption on page 298](#).
6. On a web browser, go to <https://172.16.xxx.xxx> to access FortiPAM GUI.
To upload the FortiPAM license file, see [Uploading the license file to FortiPAM-VM on page 42](#).
7. Optionally, enable displaying a login disclaimer message to show the last successful or failed login date and time:

```
config system global
  set post-login-banner enable
end
```

For a detailed example on setting up the login disclaimer using the CLI console, see [Disclaimers via the CLI on page 382](#).

To set up the login disclaimer using the GUI, see the *Login Disclaimer* option in [System > Settings](#).

8. After logging in to the FortiPAM GUI, go to *Log & Report > Email Alert Settings*, and:
 - a. Select *Enable Email Notification*.
 - b. Add receiver email addresses for critical system notifications in the *Critical System Notification* tab.
See [Email alert settings on page 302](#) and [Email alert when the glass breaking mode is activated example on page 303](#).

To update a firmware image:

1. Enter maintenance mode. See [Maintenance mode](#).
2. In the user dropdown on the top-right, go to *System > Firmware*.
The *Firmware Management* window opens.
3. Go to *File Upload*:
 - a. Select *Browse*, then locate the `image.out` FortiPAM firmware image on your local computer.
 - b. Click *Open*.
4. Click *Confirm and Backup Config*. FortiPAM then reboots and the firmware has been updated.



FortiPAM may take few minutes to reboot.

FortiPAM with TPM

FortiPAM supports TPM (Trusted Platform Module) to improve protection for secret credentials.



It is suggested that you enable TPM when you initially install FortiPAM.

Do not enable/disable (v)TPM and `private-data-encryption` frequently.

It is suggested that you backup your configuration before you disable or reenable (v)TPM or `private-data-encryption`.

If `private-data-encryption` is changed, backup the new data too.

To check if the FortiPAM hardware device has TPM capability:

1. Before enabling TPM on FortiPAM, enter the following CLI command:

```
diagnose tpm selftest
```

If the output is `Successfully tested. Works as expected`, then TPM is installed on your FortiPAM hardware device.

To enable TPM on FortiPAM hardware device:

1. In the CLI console, enter the following commands:

```
config system global
    set private-data-encryption enable
end
```

FortiPAM-VM with vTPM enabled

If FortiPAM is a VM instance, the vTPM (virtual TPM) package must be installed, and vTPM enabled then.

See [Appendix C: Installing vTPM package on KVM and adding vTPM to FortiPAM-VM on page 406](#).



On FortiPAM-VM, TPM can only be enabled after enabling vTPM.

To enable vTPM on FortiPAM-VM:

1. In the CLI console, enter the following commands:

```
config system global
    set v-tpm enable
end
```

To enable TPM on FortiPAM-VM:

FortiPAM-VM must be in maintenance mode to change TPM settings.

1. In the CLI console, enter the following commands:

```
config sys maintenance
    set mode enable
end
config system global
    set private-data-encryption enable
end
```

Be carefull!!!This operation will refresh all ciphered data!

Backup the current configuration file at first!

```
Do you want to continue? (y/n)y
Please type your private data encryption key (32 hexadecimal numbers):
0123456789abcdef0123456789abcdef
Please re-enter your private data encryption key (32 hexadecimal numbers) again:
0123456789abcdef0123456789abcdef
Your private data encryption key is accepted.
```



The key must be the same for data restoration between source FortiPAM and destination FortiPAM.

To disable TPM:

1. In the CLI console, enter the following commands:

```
config sys maintenance
  set mode enable
end
config system global
  set private-data-encryption disable
end
```

Be carefull!!!This operation will refresh all ciphared data!

+Backup the current configuration file at first!

+Do you want to continue? (y/n)y

For FortiPAM-VM, vTPM should be disabled after disabling TPM.

To disable vTPM for FortiPAM-VM:

1. In the CLI console, enter the following commands:

```
config system global
  set v-tpm disable
end
```

This operation will stop using vTPM module

Do you want to continue? (y/n)y

Connecting to target remote systems

Requirements to connect to a target server or PC:

1. Install PuTTY using default settings. See [Download PuTTY](#).
2. Optionally, install VNC Viewer. See [Download VNC Viewer](#).
3. Optionally, install TightVNC. See [Download TightVNC](#).
4. Optionally, install WinSCP for file transfer. See [Download WinSCP](#).
5. Optionally, you can engage web browser-based SSH, RDP, or VNC remote connections in the absence of FortiClient.

Licensing

FortiPAM platforms work in evaluation mode until licensed.

In the evaluation mode:

1. A maximum of 2 users are allowed; a default *Super Administrator* and an additional user.
2. You can log in to the firewall VIP using `https`.
3. The evaluation license expires after 15 days.
4. All the features are available. You can create secret and launch secrets for a target server.
5. FortiPAM does not have a valid serial number.
6. No FortiCare support is available.



FortiPAM configured with less than 2 CPUs and 2048 MB of RAM works in the evaluation mode until licensed. Otherwise, a valid license is required.



DLP is available for secret launching only when you have a valid Advanced Malware Protection (AVDB & DLP) license.

Registering and downloading your license

After placing an order for FortiPAM-VM, a license registration code is sent to the email address used in the order form. Use the license registration code provided to register the FortiPAM-VM with [FortiCloud](#).

Upon registration, download the license file. You will need this file to activate your FortiPAM-VM. You can configure basic network settings from the CLI to complete the deployment. Once the license file is uploaded, the CLI and GUI are fully functional.

1. Go to FortiCloud and create a new account or log in with an existing account.
The *Asset Management* portal opens.
2. On the *Asset Management* portal, click *Register Now* to register FortiPAM.
3. Provide the registration code:
 - a. Enter a registration code.
 - b. Choose your end user type as either a government or non-government user.
 - c. Click *Next*.
4. The *Fortinet Product Registration Agreement* page displays. Select the check box to indicate that you have read, understood, and accepted the service contract. Click *Next*.
5. The *Verification* page displays. Select the checkbox to indicate that you accept the terms. Click *Confirm*.
Registration is now complete and your registration summary is displayed.
6. On the *Registration Complete* page, download the license file (`.lic`) to your computer.
You will upload this license to activate the FortiPAM-VM as shown in [Uploading the license file to FortiPAM-VM](#).

Note: After registering a license, Fortinet servers can take up to 30 minutes to fully recognize the new license. When you upload the license file to activate the FortiPAM-VM, if you get an error that the license is invalid, wait 30 minutes and try again.

When FortiPAM is initially deployed, it is in evaluation mode. Once you have downloaded the license (.lic) file from FortiCloud, you must load the .lic file to FortiPAM so that FortiPAM has a valid serial number.

Uploading the license file to FortiPAM-VM

There are two methods to upload the license file to FortiPAM-VM.

To upload the license via the FortiPAM-VM GUI:



You must be in maintenance mode to be able to upload a license. See Maintenance mode in [Admin on page 21](#).

1. Log in to FortiPAM-VM from a browser.
Access FortiPAM by using the IP address configured on FortiPAM port1.
The *Upload License File* pane appears immediately after you log in.
If FortiPAM is in evaluation mode, go to *Dashboard > Status*, click the *Virtual Machine* widget, and click *FortiPAM VM License*.
-



Use the `https` prefix with the FortiPAM IP address to access the FortiPAM-VM GUI.

2. In the *Upload License File* pane, select *Upload* and browse to the license file on your management computer.
 3. Click *OK*.
 4. After the boot up, the license status changes to valid.
-



Use the CLI command `get system status` to verify the license status.

To upload the license through the public IP address using SCP:

Use the following command:

```
scp <license_file> admin@<public_ip_address>:vmlicense
```

For example:

```
$ scp FPAVULTM23000007.lic admin@52.52.143.64:vmlicense
admin@52.52.143.64's password:
FPAVULTM23000xxx.lic 100% 9128 344.0KB/s 00:00
100-install VM license completed
```

License expiry and renewal

FortiPAM must have a valid license to provide all the services. Therefore, you must keep track of the license status.



By default, FortiPAM sends license expiration notification 30 days before a license expires.

The license expiry notification timing can be adjusted by using the following CLI command:

```
config alertemail setting
  set FDS-license-expiring-days 30 #adjust the number of days
end
```

To renew a license, contact the FortiPAM sales team. After purchasing FortiPAM services, you receive the service registration document that includes the service name in the title and a contract registration code.

Follow the procedure as detailed in [Renewing FortiPAM-VM license on page 45](#) to renew FortiPAM-VM license.

License status

FortiPAM license status can be found in the *Licenses* widget available in *Dashboard > Status*. See [Licenses widget on page 52](#).

Email alert for license expiration

License expiration email notification is one of the critical system notifications.



When a FortiPAM license is about to expire, i.e., the license is expiring within the next 30 days; a warning dialog appears when you log in to FortiPAM.

Also, a red banner appears on the top once you are logged in, alerting you about license expiry.

Your FortiPAM license is expiring in 15 days.

To set up email alerts for license expiry:

1. Ensure that *Email Service* is set up in *System > Settings*. See [Settings on page 324](#).
2. Go to *Log & Report > Email Alert Settings*, and select *Enable email notification*.
3. In the *Critical System Notification* tab:
 - a. In *From*, enter the email address of the sender.
 - b. In *To*, enter the email address of the receiver.
4. Click *Apply*.

Alternatively, you can add an email address where the notification is sent when creating or editing a user in *User Management > User List* (*Configure User Details* tab).



For expiring Advanced Malware Protection and FortiCare support, license expiration email notifications and warnings are sent to the administrator.

CLI configuration for setting up email alerts for license expiry - example:

```
config system automation-action
  edit "License Expired Notification Email"
    set action-type email
    set email-subject "FortiPAM %%log.devname%% %%log.logdesc%%"
    set email-to "admin1@fortinet.com" "admin2@fortinet.com" # receiver email address
    set message "Your license is expiring soon. Please renew at your earliest
      convenience. If your FortiPAM Subscription license is expired, only super
      admin will be allowed to access FortiPAM until a new license is applied.
      Detail:
      %%log%%"
    set description "Default automation action configuration for sending an
      email when a license is near expiration."
  next
end
```

Subscription license

FortiPAM-VM is licensed by annual subscription. The FortiPAM-VM subscription license controls the licensed user seats. Once the license expires:

1. Only a user with *Super Administrator* role can log in to the FortiPAM GUI.
2. FortiPAM goes into maintenance mode.

In the maintenance mode:

 - a. All secrets/folders are read-only.
 - b. Critical processes are suspended including manual and scheduled password changing.
3. You cannot launch secrets.



A *Super Administrator* can enable the glass breaking mode to see all the secrets.



Although not recommended, a *Super Administrator* can promote normal users to the *Super Administrator* role, allowing users to continue logging in to FortiPAM.



Users with permission, such as the *Default Administrator* role, can still access FortiPAM through `ssh` and the CLI console.

Advanced Malware Protection (formerly AntiVirus and DLP license)

The FortiPAM-VM subscription license includes Advanced Malware Protection and FortiCare support. For FortiPAM hardware models, Advanced Malware Protection and FortiCare support licenses are purchased separately as annual contracts.

The Advanced Malware Protection (AVDB & DLP) licenses are related to the file scanning feature in file launchers. Once the Advanced Malware Protection license expires:

1. The antivirus scanning continues to work, however the antivirus database is not updated and no new signatures are added.
2. DLP feature stops working. The DLP feature requires a valid license.

Renewing FortiPAM-VM license

To renew FortiPAM-VM license:

1. Purchase a new license for the appropriate number of seats.
2. Copy the *Contract Registration Code* and save it for later use.



3. You can register the code to FortiCloud by either:
 - a. Registering via the FortiPAM GUI:
 - i. Log in to FortiPAM and go to *System > FortiGuard License*.

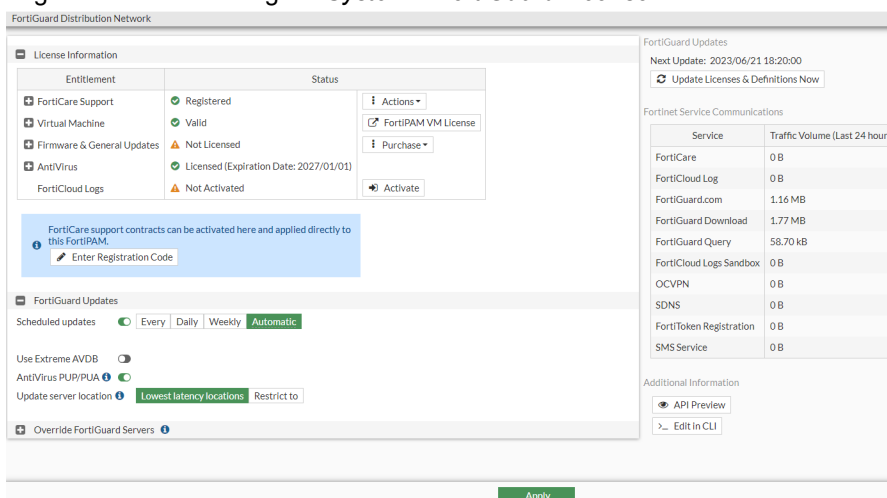

- ii. In *License Information*, click *Enter Registration Code*. The *Enter Registration Code* window opens.

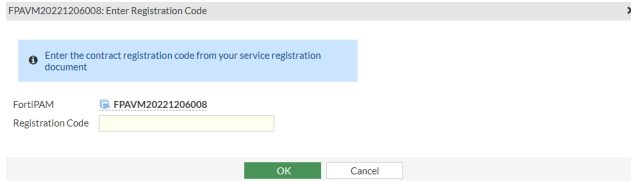

- iii. In *Registration Code*, enter the *Contract Registration Code* that you saved in step 2.
 - iv. Click *OK*.
 - v. Click *Apply*.
- b. Registering directly on FortiCloud:**
- i. Go to [FortiCloud](#) and create a new account or log in with an existing account. The *Asset Management* portal opens.
 - ii. Go to *Products > Product List*.
 - iii. Double-click your FortiPAM unit, and in *Registration*, select *Renew Contract*.

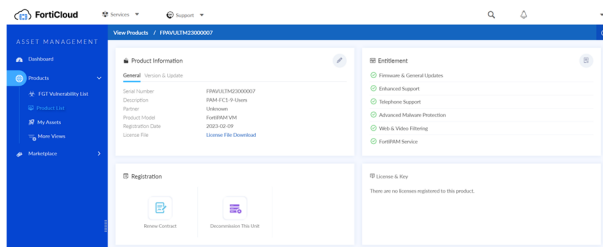

- iv. Enter the *Contract Registration Code* that you earlier saved in step 2 in the *Contract Number* field.
- v. In *Choose End User Type*, select your end user type as either government or a non-government user.

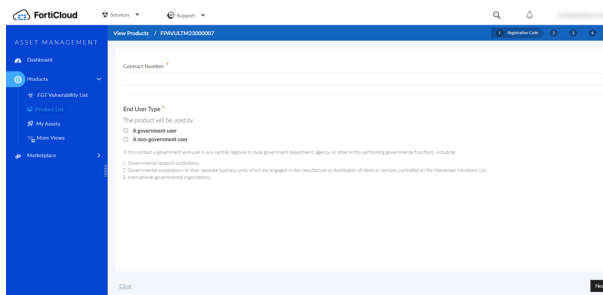

- vi. Click *Next* and follow the prompts to complete renewing the license.

In *Entitlement*, click *Show Contracts* to see the contracts with their expiration dates.

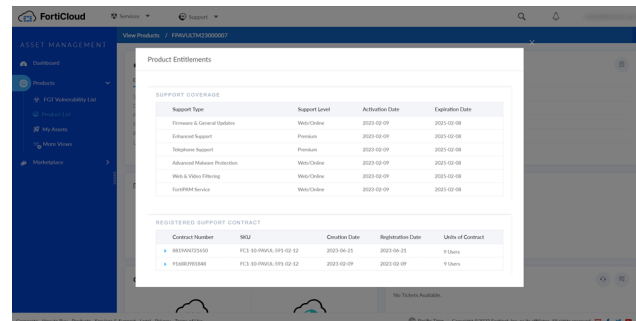

Dashboard

The *Dashboard* page displays widgets that provide performance and status information, allowing you to configure some basic system settings. These widgets appear on a single dashboard.

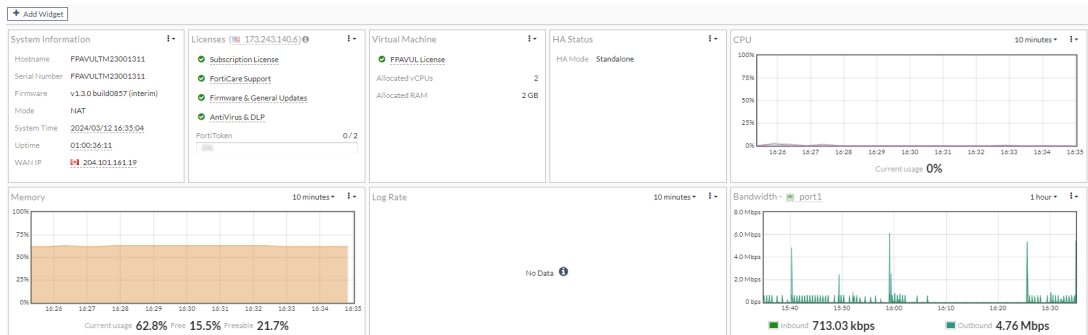

When you select the vertical ellipses (⋮) option next to a dashboard the following actions are available:

Edit Dashboard	Select to edit the selected dashboard's name.
Delete Dashboard	Select to delete the selected dashboard.
 <p>The <i>Status</i> dashboard cannot be deleted.</p>	
Add Menu Shortcut	Select to add the selected dashboard to <i>Menu Shortcuts</i> .

The following widgets are displayed in the *Status* dashboard by default:

System Information	Displays basic information about the FortiPAM system including host name, serial number, firmware version, mode, system time, uptime, and WAN IP address. From this widget you can manually update the FortiPAM firmware to a different release. See Uploading a firmware on page 22 and System information widget on page 50 . You can also configure system settings using this widget. For information on system settings, see Settings on page 324 .
Licenses	Displays the status of your license and FortiGuard subscriptions. See Licenses widget on page 52 .
Virtual Machine	Displays license information, number of allocated vCPUs, and how much RAM has been allocated. See VM license on page 56 .
HA status	Displays HA mode. See High availability on page 341 .
CPU	The real-time CPU usage is displayed for different time frames. Select the time frame from the dropdown at the top of the widget. Hovering over any point on the graph displays the average CPU usage along with a time stamp.



To see per core CPU usage, select the CPU widget and click *Show per core CPU usage*.

Memory	Real-time memory usage is displayed for different time frames. Select the time frame from the dropdown at the top of the widget. Hovering over any point on the graph displays the percentage of memory used along with a time stamp.
Log Rate	Displays the real-time log rate. Select the time frame from the dropdown at the top of the widget. See Log settings on page 295 .
Bandwidth	Displays the real-time incoming and outgoing traffic bandwidth for the selected interface. Select the time frame from the dropdown at the top of the widget. Hovering over any point on the graph displays the bandwidth with a time stamp.

You can add the *Interface Bandwidth* widget to monitor the real-time incoming and outgoing traffic bandwidth of the selected interface over the selected time frame.

You can add the following *System* widgets to the *Dashboard*:

Administrators	Information about active administrator sessions.
HA Status	HA status of the device.
License Status	Status of various licenses, such as FortiCare Support and IPS.
System Information	General system information of the FortiPAM including hostname, serial number, and firmware version.
Top System Events	Show system events.
Virtual Machine	Virtual machine license information and resource allocations.

You can add the following *Resource Usage* widgets to the *Dashboard*:

CPU Usage	Real-time CPU usage over the selected time frame.
Log Rate	Real-time log rate over the selected time frame.
Memory Usage	Real-time memory usage over the selected time frame.

Adding a widget to a dashboard

To add a widget to a dashboard:

1. In a dashboard, select *Add Widget*.
The *Add Dashboard Widget* window opens.

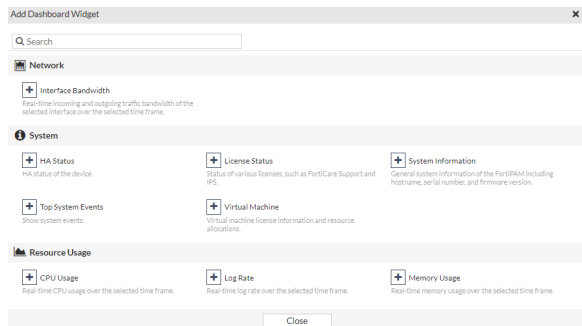

2. Select the widget you want to add to the dashboard.
The *Add Dashboard Widget - Widget Name* window opens.
3. Enter the following information:

Fabric member	See Fabric Member .
Interface	From the dropdown, select an interface or create a new interface. Note: The option is only available when adding the <i>Interface Bandwidth</i> widget.
Note: Options in <i>Time period</i> and <i>Sort by</i> may vary depending on the widget you intend to add.	
Time Period	Select from the following time periods to display: <ul style="list-style-type: none"> • <i>5 minutes</i> • <i>1 hour</i> • <i>24 hours</i>
Visualization	Select the type of chart to display. Note: For the <i>Top System Events</i> widget only the <i>Table View</i> is available.
Sort by	Sort by: <ul style="list-style-type: none"> • <i>Level</i> • <i>Events</i>

4. Click *Add Widget*.

Widget actions

All or some of the following actions are available for a widget when you click the vertical ellipsis (⋮) option for a widget:

Resize	Select and then select the number of squares you want to extend the widget to.
Settings	Select and then in <i>Edit Dashboard Widget - Widget Name</i> , specify the <i>Fabric Member</i> , interface (if available), and click <i>OK</i> . Select from the following options: <ul style="list-style-type: none"> • <i>Default:</i> Uses the current fabric member. • <i>Specify:</i> Select a fabric member from the FortiPAM dropdown, i.e., a FortiPAM instance.



Choosing a specific fabric member for this widget will override the behavior for the entire dashboard. After this is done, the fabric member selection is on each individual widget.

- *Interface*: From the dropdown, select an interface or create a new interface.

Remove

Select x to remove the widget.



Select the pin (📌) icon on a widget to expand and pin hidden content.

Adding a custom dashboard

To add a custom dashboard:

1. In the menu, go to *Dashboard* and select +. The *Add Dashboard* dialog opens.



2. In *Add Dashboard*, enter a name for the new dashboard.
3. Click *OK*.
A new dashboard with no widget is set up.
4. Use *Add Widget* to add new widgets to the dashboard.

System information widget

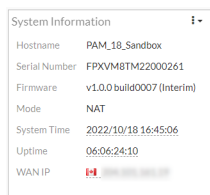
The system dashboard includes a *System Information* widget, which displays the current status of FortiPAM and enables you to configure basic system settings.



The following information is available on this widget:

Host Name	The identifying name assigned to this FortiPAM unit. For more information, see Changing the host name on page 51 .
Serial Number	The serial number of FortiPAM. <hr/>  The serial number is unique to FortiPAM and does not change with firmware upgrades. The serial number is used for identification when connecting to the FortiGuard server. <hr/>
Firmware	The version and build number of the firmware installed on FortiPAM. To update the firmware, you must download the latest version from FortiCloud . See Uploading a firmware on page 22 .
Mode	The current operating mode of the FortiPAM unit. <hr/>  A unit can operate in NAT mode or transparent mode. <hr/>
System Time	The current date and time according to the FortiPAM unit's internal clock. For more information, see Configuring the system date, time, and time zone on page 51 .
Uptime	The duration of time FortiPAM has been running since it was last started or restarted.
WAN IP	The WAN IP address and location. Additionally, if the WAN IP is blocked in the FortiGuard server, there is a notification in the notification area, located in the upper right-hand corner of the <i>Dashboard</i> . Clicking on the notification opens a window with the relevant blocklist information.

Changing the host name

The *System Information* widget displays the full host name.

To change the host name:

1. Go to *Dashboard > Status*.
2. Select the *System Information* widget and then click *Configure settings in System > Settings*. The *System Settings* window opens.
3. In *System Settings*, update the host name in *Host name*.
4. Click *Apply*.

Configuring the system date, time, and time zone

You can either manually set the FortiPAM system date and time, or configure the FortiPAM unit to automatically keep its system time correct by synchronizing with an NTP server.

To configure the date and time manually:

1. Go to *Dashboard > Status*.
2. Select the *System Information* widget and then click *Configure settings in System > Settings*.
3. From the *Time Zone* dropdown, select a timezone.
If you want to change the date and time manually, select *Manual Settings* for *Set Time*:
 - a. In *Date*, either enter the date or select the *Calendar* icon and then select a date.
 - b. In *Time*, either enter the time or select the *Clock* icon and then select a time.
4. Click *Apply* to save changes.

To automatically synchronize FortiPAM unit's clock with the NTP server:

1. Go to *Dashboard > Status*.
2. Select the *System Information* widget and then click *Configure settings in System > Settings*.
3. From the *Time Zone* dropdown, select a timezone.
4. In *Set Time*, select *NTP*.
5. In *Select Server*, either select *Fortiguard* or *Custom*.
If you select *Custom*, enter the *Custom Server IP Address*.



Custom server details must be configured in the CLI.

6. In *Sync interval*, enter how often, in minutes, that the device synchronizes time with the NTP server.
7. Click *Apply* to save changes.

Licenses widget

The *Licenses* widget displays the statuses of your licenses and FortiGuard subscriptions. It also allows you to update your device's registration status and FortiGuard definitions.

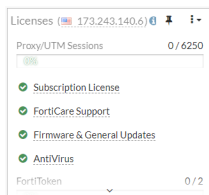

Hovering over the *Licenses* widget displays status information for *Subscription License*, *FortiCare Support*, *Firmware & General Updates*, *AntiVirus*, and *FortiToken*.

To view details on licenses, see [FortiGuard Distribution Network](#) on page 52.

FortiGuard Distribution Network

The FortiGuard Distribution Network page provides information and configuration settings for FortiGuard subscription services. For more information about FortiGuard services, see [FortiGuard Labs](#).

To view and configure FortiGuard connections:

1. Go to *Dashboard > Status*.
2. In the *License* widget, click any option except *FortiToken*, and select *View details in System > FortiGuard*. The *FortiGuard Distribution Network* window opens.

The following settings are available in the window:

License Information

FortiCare Support

The availability or status of your unit's support contract.

You can update your registration status by selecting *Enter Registration Code* and loading the license file from a location on your computer.



From the *Actions* dropdown:

- Select *Login to My Account* to log in to FortiCloud.
- Select *Transfer FortiPAM to Another Account* to transfer this FortiPAM device to another FortiCloud account. Fill in the verification details and then review and transfer the device.

Virtual Machine

To upload or check your virtual machine license, select *FortiPAM VM License*. See [Uploading a license file](#).

Firmware & General Updates

Displays the status of *Application Control Signatures*, *Device & OS Identification*, and *Internet Service Database Definitions*.

To upgrade the database:

1. From the *Actions* dropdown, select *Upgrade Database*.

2. Select *Upload* and locate the application control signatures file from your computer.
3. Select *OK*.



From the *Actions* dropdown, select *View List* to see a list of application control signatures.



To purchase upgrades, select *Enter Registration Code* from the *Purchase* dropdown, enter the *Registration Code* in the new window, and click *OK*.

Antivirus

The FortiGuard AntiVirus Service provides fully automated updates to ensure protection against the latest content level threats. It employs advanced virus, spyware, and heuristic detection engines to prevent both new and evolving threats from gaining access to your network and protects against vulnerabilities.



To renew the AntiVirus service, select *Enter Registration Code* from the *Renew* dropdown, enter the *Registration Code* in the new window, and click *OK*.

FortiCloud Logs

To activate FortiCloud logs:

1. Select *Activate*.
2. Confirm the password of your FortiCloud account.
3. Select from the following domains:
 - *Europe*
 - *US*
 - *Global*
4. Ensure that *Send logs to FortiCloud Logs* is enabled.
5. Click *OK*.

FortiGuard Updates

Scheduled updates

Enable to receive scheduled updates and then select when the updates occur: Every 1-23 hours, *Daily* at a specific hour, or *Weekly* on a specific day at a specific hour, or automatically within every one hour period.

Note: The option is enabled by default.

Use Extreme AVDB

Note: The option is disabled by default.

AntiVirus PUP/PUA

Enable antivirus grayware checks for potentially unwanted applications.

Note: The option is enabled by default.

Update server location

Update the FortiGuard server location to:

- *Lowest latency locations*
- or

- Restrict to:
 - *US only*
 - *EU only*



Changing the server location overrides all FortiGuard/FortiCloud/FortiCare servers.

Override FortiGuard Servers

By default, the FortiPAM unit updates signature packages and queries rating servers using public FortiGuard servers. You can override this list of servers. You can also disable communication with public FortiGuard servers.

See [Override FortiGuard Servers on page 55](#).

Override FortiGuard Servers

To override FortiGuard servers

1. In step 2 when [configuring FortiGuard connections](#), select *Create New* in the *Override FortiGuard Servers* pane. The *Create New Override FortiGuard Server* window opens.

Create New Override FortiGuard Server

Address Type: IPv4 | IPv6 | FQDN

Address:

Type: Both

2. Enter the following information:

Address Type	Select from the following three options: <ul style="list-style-type: none"> • <i>IPv4</i> • <i>IPv6</i> • <i>FQDN</i>
Address	Depending on your selection in <i>Address Type</i> , enter an IPv4/IPv6 address, or an FQDN.
Type	Select the type of update to receive: <ul style="list-style-type: none"> • <i>Antivirus & IPS updates</i> • <i>Filtering</i> • <i>Both</i>

3. Click *OK*.



Select a server in the list and select *Edit* to edit the server.



Select servers in the list and select *Delete* to delete the servers. To remove multiple servers quickly, select multiple rows in the list by holding down the *Ctrl* or *Shift* keys and then select *Delete*.



To update the licenses and definition immediately, select *Update Licenses & Definitions Now*.

VM license

Click on the *Virtual Machine* widget and then select *FortiPAM VM License*.

The *FortiPAM VM License* page displays whether the license is valid or not, the allocated vCPUs, RAM, and the license expiry date.



You must be in maintenance mode to be able to upload a license. See [Maintenance mode in Admin on page 21](#).

FortiPAM VM License (Read Only)

⚠ System is currently not in maintenance mode. Cannot upload license

✔ License is valid.

Allocated vCPUs 4 / 8
Allocated RAM 4 GiB
Expires on 2023/08/31

Upload License File

Select file

To upload a license, see [Uploading a license](#).

Secrets

User name and password/key of servers can be securely stored in FortiPAM as secrets. The secrets contain information on login, credentials, and the target server IP address. The end user can use the secret to access servers.

In FortiPAM, actual credentials are protected, and FortiPAM users cannot access the credentials except in some cases as described [below](#). Login credentials can be changed automatically and manually for different use cases.



User names and password of domain controller can be securely stored in FortiPAM secrets.



Website user names and passwords can be securely stored in FortiPAM.

FortiPAM works with FortiClient and the browser extension to automatically fill the user name and password when the user browses a website.

Users with the following permission can view secret passwords on the GUI:

- *Owner*
- *Edit*
- *View* (Only for users with roles where *View Encrypted Information* is enabled)

Components:

- **Servers:** the server that the end users require to access.
- **FortiClient:** supports privileged activity recording and ZTNA tunnel setting up in proxy mode.
- **FortiPAM:** back to back user agent to access the target website in proxy mode.



FortiPAM supports client and browser to launch a session to servers.

FortiPAM supports the following servers and credentials:

SSH server: Password mode and Key mode

RDP server

macOS VNC server

Linux VNC server

Integrated with Windows AD by Samba or LDAPs

Web account credentials



Besides client mode launch for secrets, FortiPAM also supports browser mode where no client software is required.

The following client and browser modes are supported by FortiPAM:

- Client mode: PuTTY, Windows Remote Desktop, RealVNC, TightVNC, and WinSCP etc
- Browser mode: Web SSH, Web RDP, Web VNC, Web SMB, Web SFTP and Web Account.

In *Secrets*, you can access the following tabs:

- [Secret list on page 58](#)
- [Target list on page 92](#)
- [Gateway on page 100](#)
- [Personal/public folder on page 106](#)
- [My requests list on page 116](#)
- [Approval list on page 119](#)
- [Job list on page 123](#)
- [Discovery on page 126](#)

Secret list

Secret List in *Secrets* displays a list of configured secrets.



To access any of the secrets, you require *Secret List* access.

No matter what permissions the secrets are provided, the secrets are not available anymore if the access control for *Secret List* in the *Role* page is set to *None*. See [Role on page 243](#).

For each secret, the following columns are displayed by default:

- *Name*
- *Target Address*
- *Description*
- *Auto Password Changing*
- *Last Launch Time*
- *Last Password Change*
- *Last Password Verification*
- *Folder*
- *Template*
- *Creation Time*

Name	Target Address	Description	Auto Password Changing	Last Launch Time	Last Password Change	Last Password Verification	Folder	Template	Creation Time
test			Disabled	2024/02/16 16:57:32	Never changed	Never verified	admin	Cisco Enable Secret	2024/02/16 16:57:32
test_secret			Disabled	2024/02/20 13:41:24	Never changed	Never verified	test	Cisco Enable Secret	2024/02/15 14:50:36
test_video			Disabled	2024/02/16 17:18:24	Never changed	Never verified	admin	Cisco Enable Secret	2024/02/16 17:18:08



The *Description* column is not visible by default. To display the *Description* column, select *Configure Table* icon as you click the header for the left-most column, select *Description* and then click *Apply*.



The *Last Password Verification* column gives an overview of the secret password status.



Use the sorting arrows next to the column names to sort columns in an ascending or descending order, e.g.:

Name ▲

Clicking the upper arrow in the *Name* column arranges the secret entries in an ascending order.

The *Secrets List* tab contains the following options:

Create	Select to create a new secret. See Creating a secret on page 60 .
Upload	Select and then select <i>Upload Secret</i> to upload secrets using the secret upload template file, or download the secret upload template by selecting <i>Download Template</i> . See Uploading secrets using the secret upload template on page 84 .
Edit	Select to edit the selected secret.
	<div data-bbox="609 1213 690 1318" data-label="Image"> </div> <div data-bbox="735 1201 1427 1333" data-label="Text"> <p>When a secret request is approved, the <i>Launcher Status</i> timer shows the remaining time till you (as a requester) have access to the secret when you double-click to open the secret in <i>Secrets > Secret List</i>.</p> </div>
	<div data-bbox="599 1390 698 1486" data-label="Image"> </div> <div data-bbox="735 1407 1429 1472" data-label="Text"> <p>When editing a secret, click <i>Discard Changes</i> to discard all the changes you made.</p> </div>
Move	Select to move the selected secret.
Delete	Select to delete the selected secrets.
Clone	Select to clone the selected secret.
Add favorite	Select to add the selected secret to the favorite folder.
Remove favorite	Select to remove the selected secret from the favorite folder.
Launch Secret	Launch the selected secret. See Launching a secret on page 82 .

Make Request

Make request to launch or perform a job on the secret. [Make a request on page 117.](#)

Search

Enter a search term in the search field, then hit `Enter` to search the secrets list. To narrow down your search, see [Column filter](#).

The following column filters are available:

- *Name*
- *Target Address*
- *Description*
- *Auto Password Changing*
- *Last Launch Time*
- *Last Password Change*
- *Last Password Verification*
- *Folder*
- *Template*
- *Creation Time*
- *ID*



Not all options are available for a secret. The options depend on how the secret has been set up, e.g., The *Make Request* option is only available when the secret has *Requires Approval to Launch Secret* enabled.

Creating a secret

To create a secret:

1. Go to *Secrets > Secret List*.
Alternatively, go to *Personal Folder/Public Folder* in *Secrets*, select *Open Tree*, locate the folder where you intend to add the secret, and click *Open*.
From the *Create* dropdown, select *Secret*, and skip to step 6.
2. In *Secret List*, select *Create*.
The *Create New Secret in:* dialog appears.
3. Select the folder where you intend to add the secret.



The folder is already selected if you are creating secret from inside a folder.

4. Select *Create*.
The *General* tab opens.

Install CA Certificate for Web Launching

The browser may warn untrusted site even its certificate is valid. It is because the traffic is provided by FortiPAM in the proxy mode. Download and install the CA certificate from FortiPAM to resolve the false positive untrusted site warning.

During installation, you may be asked to specify the certificate store (trusted root CA/Intermediate CA). Most of the platforms can automatically select a certificate store based on the type of certificate. You can also specify a location for the certificate manually. For the later case, check the "Issued by" and "Issued by" fields in the "Certificates" tab of the "Certificate" dialog. If they are the same, choose "Trusted Root Certification Authorities". If different, choose "Intermediate Certification Authorities".

Download the certificate file, double-click and follow the wizard to install it.

[Download CA Certificate](#)

Documentation
[Online Help](#)

5. To switch to Service Setting, Permission, or Dependency tabs, select the tab.



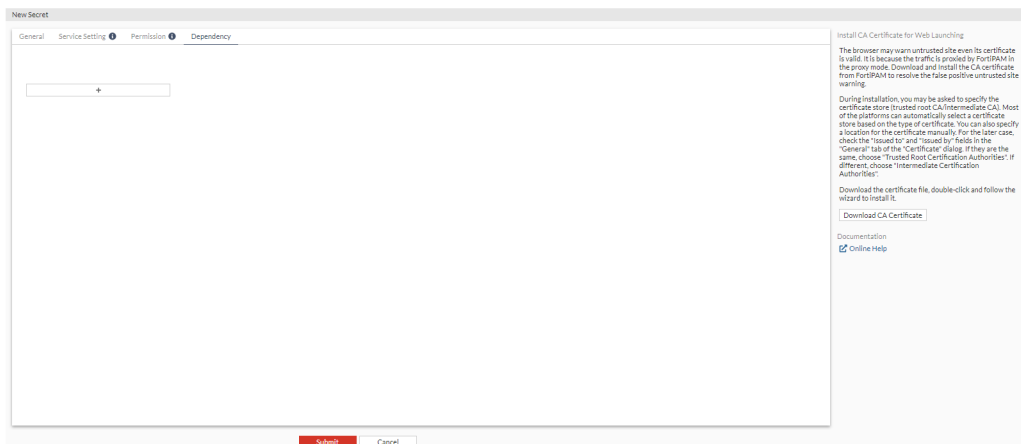

Users	Permission
admin	Owner

ID	Groups	Permission
No results		



6. Enter the following information:

Name	Name of the secret.
Folder	<p>The folder where the secret is added. See Personal/public folder on page 106.</p> <hr/> <div style="display: flex; align-items: center;"> <p>The folder is already selected in step 2. Use the dropdown, if you want to change the folder.</p> </div>
Target	<p>Enable and then from the dropdown, select a target for the new secret being created.</p> <p>In the dropdown, select + to create a new target. See Creating a target on page 93.</p> <hr/> <div style="display: flex; align-items: center;"> <p>The <i>Default Template</i> from the target will automatically be used as <i>Template</i> for the secret.</p> <p>If the <i>Default Template</i> is updated later on, the <i>Template</i> for the secret will not be automatically updated. It must be updated by editing the secret. See To change the template after selecting one: on page 63.</p> </div>
Privilege Account	<p>Select Yes or No to indicate if the secret is for a privilege account.</p> <p>This option is only available when a <i>Target</i> is selected.</p>
Gateway	<p>A gateway is selected if the associated target includes a gateway.</p> <p>A gateway, e.g., a FortiGate or a FortiProxy device, is used when a target is not reachable directly from FortiPAM. It allows you to proxy the connection to the target. See Gateway on page 100.</p> <hr/> <div style="display: flex; align-items: center;"> <p>The option is non-editable.</p> </div>

	<div style="text-align: center;">  </div> <p>The option is only available when you select a target with gateway included. See Creating a target on page 93.</p>
<p>Template</p>	<p>From the dropdown, select a template.</p> <p>Select <i>Create</i> to create a new template. See Creating secret templates on page 137.</p> <hr/> <div style="text-align: center;">  </div> <p>To change the template after selecting one:</p> <ol style="list-style-type: none"> 1. Select the pen icon. 2. In the <i>Convert Secret Template</i> pane, select a template to transfer old field values to new fields where applicable. 3. Click <i>OK</i>.
<p>Server Information</p>	<p>Disable to inherit server information from the <i>Template</i>.</p> <p>Enable to select general type of server to which the secret is intended to connect:</p> <ul style="list-style-type: none"> • <i>Unix-Like</i> • <i>Cisco</i> • <i>FortiOS</i> • <i>Other</i>
<p>Associated Secret</p>	<p>Enable and then from the dropdown, select an associated secret for the new secret being created.</p> <p>When enabled, changing password or verifying password requires credentials from the associated secret.</p> <p>Note: The option is disabled by default.</p>
<p>Description</p>	<p>Optionally, enter a description.</p>
<p>Fields</p>	<p>Enter a value in a field.</p> <p>For the <i>Password</i> field, click the <i>Generate</i> button to automatically generate the password following the password policy set in Password policies on page 188.</p> <hr/> <div style="text-align: center;">  </div> <p>The options in the fields depend on the selected template.</p> <hr/> <div style="text-align: center;">  </div> <p>For fields where a host is required when using the FortiPAM browser extension, enter the URL instead.</p>
<p>Secret Setting</p>	



Some settings may not be configurable as they are protected by the policy that applies to the folder where the secret is added.



The owner of the secret must configure password verification and change settings before the secret utilizes the password changer and password verification. However, a user can manually trigger these actions if they have sufficient permissions.

Automatic Password Changing	<p>Enable/disable automatic password changing.</p> <p>When enabled, password changer for secrets is activated to periodically change the password.</p>
Recursive	<p>Displays the password changing schedule based on your selections for the related settings.</p>
Start Time	<p>The date and time when the recurring schedule begins.</p> <p>Enter date (MM/DD/YYYY) and time or select the <i>Calendar</i> icon and then select a date and time.</p>
Recurrence	<p>From the dropdown, select from the following three frequencies of recurrence:</p> <ul style="list-style-type: none"> • <i>Daily</i> • <i>Weekly</i> • <i>Monthly</i>
Repeat every	<p>The number of days/weeks/months after which the password is changed (1-400).</p>
Occurs on	<p>Select from the following days of the month when the password is automatically changed:</p> <ul style="list-style-type: none"> • <i>First</i> • <i>Second</i> • <i>Third</i> • <i>Last</i> • <i>Last Day</i> • <i>Day</i> <p>When you select <i>Day</i>, select + to add days of the month when the password is automatically changed.</p> <p>Select days of the week when the password is automatically changed.</p> <p>Note: The option is only available when <i>Recurrence</i> is set as <i>Weekly</i> or <i>Monthly</i>.</p>
Automatic Password Verification	<p>Enable/disable automatic password verification.</p> <p>When enabled, password changer for secrets is activated to periodically verify the password, and check if the target server is still available.</p>
Interval (min)	<p>The time interval at which the secret passwords are tested for accuracy, in minutes (default = 60, 5 - 44640).</p>
Start Time	<p>The date and time when the <i>Interval(min)</i> begins.</p>

Enter date (MM/DD/YYYY) and time or select the *Calendar* icon and then select a date and time.

Session Recording

Enable/disable session recording.

When enabled, user action performed on the secret is recorded.



The video file is available in the log for users with appropriate permission.

See [Over-the-shoulder monitoring \(Live recording\)](#) on page 275.

Proxy Mode

Enable/disable the proxy mode.

When enabled, FortiPAM is responsible to proxy the connection from the user to the secret.

In the proxy mode:

- Web launcher is available to users who have the permission to view the secret password.
- Web launcher is disabled for users who do not have the permission to view the secret password.

When disabled, the non-proxy (direct) mode is used. See [Modes of operation](#) on page 29.

In the non-proxy mode:

- Web launcher is available to users who have the permission to view the secret password.
- Web launcher is disabled for users who do not have the permission to view the secret password.



When launchers are disabled, the *Launch* option is unavailable and a tooltip is displayed instead:

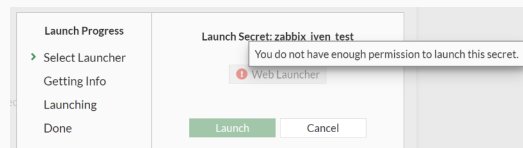

Web Proxy

Enable/disable the web proxy feature.

When accessing a target using the FortiPAM browser extension, the browser extension sends the browser requests through the FortiPAM web proxy. FortiPAM dynamically operates on the web browser tab's PAC rule (on Google Chrome and Microsoft Edge) to successfully proxy the traffic to FortiPAM based on the configured domain. On Mozilla Firefox, FortiPAM sends the request to the web proxy instead.

FortiPAM scans the incoming web traffic and can replace the password.



Using web proxy, you do not require FortiClient to launch the proxied web account secret.

To enable the web proxy feature, you must first enable the feature globally for the interface that handles incoming and outgoing traffic using the following CLI commands:

```
config system interface
  edit "port1"
    set explicit-web-proxy enable #must be enabled
  next
end
```

Alternatively, you can enable the feature by enabling *Explicit web proxy* for the interface that handles incoming and outgoing traffic. See [Creating an interface on page 309](#).

Notes:

- The option is only available when *Proxy Mode* is enabled.
- The *Web Proxy* option is inherited from the secret target. See [Creating a target on page 93](#).
- When you edit the *Web Proxy* option, you are editing the *Web Proxy* option available from within the associated secret target.

Tunnel Encryption

Enable/disable tunnel encryption.

When launching a native launcher, FortiClient creates a tunnel between the endpoint and FortiPAM. The protocol stack is HTTP/TLS/TCP.

The HTTP request gives information on the target server then FortiPAM connects to the target server. After that, two protocol options exist for the tunnel between FortiClient and FortiPAM. One is to clear the TLS layer for better throughput and performance. The other is to keep the TLS layer. The launcher's protocol traffic is inside the TLS secure tunnel.

If the launcher's protocol is not secure, like VNC, it is strongly recommended to enable this option so that the traffic is in a secure tunnel.



When there is an HTTPS Man In The Middle device, e.g., FortiGate or FortiWeb between FortiClient and FortiPAM, you must enable the *Tunnel Encryption* option. Otherwise, the connection will be disconnected, and the launching will fail.

DLP Status

Enable/disable DLP. See [Data loss prevention \(DLP\) protection for secrets on page 195](#).





DLP Profile

From the dropdown, select a DLP profile.

Antivirus Scan

Enable/disable antivirus scan.

When enabled, it enforces an antivirus profile on the secret. See [AntiVirus on page 192](#).

Antivirus Profile	From the dropdown, select an antivirus profile.
Requires Checkout	<p>Enable/disable requiring checkout. When enabled, a user has exclusive access to a secret for a limited time.</p> <hr/> <div style="display: flex; align-items: center;">  <p>At a given time, only one user can check out a secret. Other approved users must wait for the secret to be checked in or wait for the checkout duration to lapse before accessing the secret.</p> </div> <hr/> <p>See Check out and check in a secret on page 83.</p>
Checkout Duration	The checkout duration, in minutes (default = 30, 3 - 120).
Checkin Password Change	Enable/disable automatically changing the password when the user checks in.
Renew Checkout	Enable/disable renewing checkouts.
Max Renew Count	When <i>Renew Checkout</i> is enabled, enter the maximum number of renewals allowed for the user with exclusive access to the secret (default = 1, 1 - 5).
Requires Approval to Launch Secret	<p>Enable/disable requiring approval to launch a secret. When enabled, users must request permission from the approvers defined in the approval profile before gaining access. From the dropdown, select an approval profile.</p> <hr/> <div style="display: flex; align-items: center;">  <p>Use the search bar to look up an approval profile.</p> </div> <hr/> <div style="display: flex; align-items: center;">  <p>Use the pen icon next to the approval profile to edit it.</p> </div> <hr/> <p>See Make a request on page 117 and Approval flow on page 170.</p>
Requires Approval to Launch Job	<p>When enabled, users must request permission from the approvers defined in the approval profile before executing a job on a secret. From the dropdown, select an approval profile.</p> <hr/> <div style="display: flex; align-items: center;">  <p>Use the search bar to look up an approval profile.</p> </div> <hr/> <div style="display: flex; align-items: center;">  <p>Use the pen icon next to the approval profile to edit it.</p> </div> <hr/> <p>See Make a request on page 117 and Approval flow on page 170.</p>

Bypass Approval

Enable/disable secret owners to bypass the secret request/approval process, i.e., secret owners do not require approval to launch secrets they own, given that *Bypass Approval* is enabled.

Note: The option is disabled by default and only available when *Requires Approval to Launch Job* is enabled.

TOTP Setting

Enable/disable TOTP (Time-based one-time password) for the secret.

TOTP is used when the target server requires TOTP as the 2FA.

To configure TOTP settings via the CLI, see [Configuring TOTP settings via the secret CLI commands Example on page 78](#).

See [Limitations of TOTP on FortiPAM on page 145](#).

Note: The option is disabled by default.

Verification Code with

The verification code issued by:

- *3rd Party* (default)
- *FortiToken*

Note: The option is only available when TOTP status is enabled.

Shared Key

The TOTP key from the target server or any other 3rd party authenticator. The TOTP key is usually a binary string and delivered in `base64/base32` encoding format.



Use the eye icon to hide/unhide the shared key.

Note: The option is only available when the *Verification Code with* is set as *3rd Party*.

Activation Code

The FortiToken Mobile activation code.

When using FortiToken Mobile as the TOTP mobile application, an activation code from the FortiToken Mobile token issuer is required to activate the token. In that case, you must provide the activation token, and FortiPAM then acts as a surrogate for the FortiToken Mobile application.



FortiToken TOTP can only be configured via the GUI.

Note: The option is only available when *Verification Code with* is set as *FortiToken*.

Service Setting

Turn on/off the service settings.







You can individually toggle on or off each service, controlling whether or not FortiPAM is allowed to use the specific service to connect to the secret.
 The port used by each service specified in the template can also be overridden to use a custom port specific to the secret.

SSH Service	<p>Enable/disable SSH service.</p> <p>The <i>SSH Service</i> toggle controls <i>Web SSH</i>, <i>Web SFTP</i>, <i>PuTTY</i>, and the <i>WinSCP</i> launchers.</p> <p>Note: <i>SSH Filter</i>, <i>RSA Sign Algorithm</i>, and <i>Connect over SSH with</i>, and <i>SSH Auto-Password</i> options are only available when <i>Template</i> is already selected.</p>
Use Template Default Port	Use the template default port or disable and enter a port number.
SSH Filter	Enable/disable using an SSH filter profile. See SSH filter profiles on page 204 .
SSH Filter Profile	<p>From the dropdown, select an SSH filter profile.</p> <p>Note: The option is only available when <i>SSH Filter</i> is enabled.</p>
	 <p>Use the search bar to look up an SSH filter profile.</p>
Bypass for owner	<p>Enable/disable allowing secret owners to bypass the SSH command filter (default = disable).</p> <p>Once enabled, secret owners can send otherwise prohibited commands (listed in the SSH filter profile) to the targets.</p> <p>Note: The option is only available when <i>SSH Filter</i> is enabled.</p>
RSA Sign Algorithm	<p>To improve compatibility with different SSH servers, select a sign in algorithm for RSA-based public key authentication:</p> <ul style="list-style-type: none"> • <i>RSA SHA-256 signing algorithm</i> • <i>RSA SHA-512 signing algorithm</i> • <i>RSA SHA-1 signing algorithm</i> (default)
Connect over SSH with	<p>If the setting is set to <i>Self</i> (default), the secret launches SSH with its own username and password.</p> <p>If the setting is set to <i>Associated Secret</i>, the secret launches SSH with the associated secret's username and password.</p>
SSH Auto-Password	<p>Enable or disable automatically delivering passwords to the server when the user enters privileged commands (e.g., <i>sudo</i> in Unix system and <i>enable</i> in Cisco devices) in the SSH shell terminal.</p> <p>For secrets using Cisco server info template, an associated secret must be set to enable this feature.</p> <p>Note: The option only works when <i>Proxy Mode</i> is enabled.</p>
RDP Service	<p>Enable/disable RDP service.</p> <p>The <i>RDP Service</i> toggle controls <i>Web RDP</i> and the <i>Remote Desktop-Windows</i> launchers.</p>

Note: *Block RDP Clipboard*, *RDP Security Level*, *RDP Restricted Admin Mode*, and *Keyboard Layout* options are available only when *Template* is already selected.

Use Template Default Port	Use the template default port or disable and enter a port number.
Block RDP Clipboard	Enable/disable allowing users to copy/paste from the secret launcher.
RDP Security Level	<p>Select a security level when establishing a RDP connection to the secret:</p> <ul style="list-style-type: none"> • <i>Best Effort</i> (default): If the server supports NLA, FortiPAM uses NLA to authenticate. Otherwise, FortiPAM conducts standard RDP authentication with the server through RDP over TLS. • <i>NLA</i>: Network Level Authentication (CredSSP). When an RDP launcher is launched, FortiPAM is forced to use CredSSP (NLA) to authenticate with the target server. • <i>RDP</i>: FortiPAM uses the standard RDP encryption provided by the RDP protocol without using TLS (Web-RDP only). • <i>TLS</i>: RDP over TLS. FortiPAM uses secured connection with encryption protocol TLS to connect with the target server.
RDP Auto TOTP	<p>Enable/disable RDP auto Time-based One-time Password (TOTP).</p> <p>Note: The option is only available when <i>RDP Security Level</i> is set as <i>TLS</i>.</p>
RDP Restricted Admin Mode	<p>Enable/disable RDP restricted admin mode.</p> <p>Restricted admin mode prevents the transmission of reusable credentials to the remote system to which you connect using remote desktop. This prevents your credentials from being harvested during the initial connection process if the remote server has been compromised.</p> <p>Note: The option is only available when <i>RDP Security Level</i> is set as <i>Best Effort</i> or <i>NLA</i>.</p>
Keyboard Layout	From the dropdown, select a keyboard layout (default = <i>English, United States</i>)
RDP Event Filter	Enable/disable using an event filter profile. See Event filter profile on page 209 .
RDP Event Filter Profile	<p>From the dropdown, select an event filter profile.</p> <p>Note: The option is only available when <i>RDP Event Filter</i> is enabled.</p> <hr/> <div style="display: flex; align-items: center;">  <p>Use the search bar to look up an event filter profile.</p> </div> <hr/>
VNC Service	<p>Enable/disable VNC service.</p> <p>The <i>VNC Service</i> toggle controls the <i>Web VNC</i>, <i>VNC Viewer</i>, and <i>TightVNC</i> launchers.</p>
Use Template Default Port	<p>Use the template default port or disable and enter a port number.</p> <p>Note: The port number you enter is used to connect to the VNC launcher.</p>

Display Number	<p>Enter the display number to be added to the VNC port defined in the template (default = 0).</p> <p>Notes:</p> <ul style="list-style-type: none"> • The display number can only be set if the custom port on the template is the VNC default port, i.e., port 5900, and the secret uses the default template for VNC. Otherwise, the display number option is the custom port option. • The display number cannot be set with a custom port. • The option is only available when <i>Use Template Default Port</i> is enabled.
SAMBA Service	<p>Enable/disable SAMBA service.</p> <p>The <i>SAMBA Service</i> toggle controls the <i>Web SMB</i> launcher.</p>
Use Template Default Port	<p>Use the template default port or disable and enter a port number.</p>
SFTP Service	<p>Enable/disable SFTP service.</p> <p>The <i>SFTP Service</i> toggle controls the <i>Web SFTP</i> launcher.</p>
Use Template Default Port	<p>Use the template default port or disable and enter a port number.</p>
Permission	
	<p>By default, secret permission is the same as the folder where they are located.</p>
	<p>When customizing secret permission, ensure that you log in with an account with <i>Owner</i> or <i>Edit</i> permission to the secret or the folder where the secret is located.</p>
Inherit ZTNA Control	<p>Enable to inherit ZTNA control access permission from the parent folder.</p>
	<p>By default, secrets in a folder follow the ZTNA control set up in the parent folder. However, when creating or editing a secret you can customize the ZTNA control in the <i>Secret Permission</i> tab.</p>
ZTNA Control	<p>Enable to limit the permission of launching by <code>ztna-ems-tag</code>. You can choose whether to match all the tags or only one of them.</p>
	<p>The option is only available when <i>Inherit ZTNA Control</i> is disabled.</p>
Device Tags	<p>Select + to add ZTNA tags or groups.</p>

	<div data-bbox="623 216 721 310" data-label="Image"> </div> <div data-bbox="760 237 1357 300" data-label="Text"> <p>Use the search bar to look up a ZTNA tag or ZTNA tag group.</p> </div> <hr/> <div data-bbox="584 359 1333 386" data-label="Text"> <p>Only permitted devices with the selected tags are allowed to launch.</p> </div>
<p>Device Match Logic</p>	<div data-bbox="584 411 1049 438" data-label="Text"> <p>Define the match logic for the device tags:</p> </div> <div data-bbox="602 445 1336 512" data-label="List-Group"> <ul style="list-style-type: none"> • <i>OR</i>: Devices with any of the selected tags are allowed to launch. • <i>AND</i>: Devices must acquire all the selected tags to launch. </div>
<p>Inherit Permission</p>	<div data-bbox="584 537 1373 596" data-label="Text"> <p>Enable to inherit permissions that apply to the folder where the secret is located.</p> </div> <hr/> <div data-bbox="634 636 712 737" data-label="Image"> </div> <div data-bbox="760 676 1120 703" data-label="Text"> <p>The option is enabled by default.</p> </div>
<p>User Permission</p>	<div data-bbox="584 785 1380 812" data-label="Text"> <p>The level of user access to the secret. See User Permission on page 74.</p> </div> <hr/> <div data-bbox="634 852 712 953" data-label="Image"> </div> <div data-bbox="760 873 1364 932" data-label="Text"> <p>This option is only available when <i>Inherit Permission</i> is disabled.</p> </div> <hr/> <div data-bbox="584 999 1076 1026" data-label="Text"> <p>For column settings, see Tables on page 25.</p> </div>
<p>Group Permission</p>	<div data-bbox="584 1050 1440 1108" data-label="Text"> <p>The level of user group access to the secrets. See Group Permission on page 75.</p> </div> <hr/> <div data-bbox="634 1148 712 1249" data-label="Image"> </div> <div data-bbox="760 1171 1364 1230" data-label="Text"> <p>This option is only available when <i>Inherit Permission</i> is disabled.</p> </div> <hr/> <div data-bbox="584 1295 1076 1323" data-label="Text"> <p>For column settings, see Tables on page 25.</p> </div>
<p>Target Filter</p>	<div data-bbox="584 1350 1435 1446" data-label="Text"> <p>Enable/disable filtering addresses. When enabled, <i>Allow/Deny</i> addresses, i.e., create a list of allowed or blocked addresses.</p> </div> <hr/> <div data-bbox="634 1486 712 1587" data-label="Image"> </div> <div data-bbox="760 1509 1385 1568" data-label="Text"> <p>Creating allowlist/blocklist helps you improve security by allowing/blocking IP addresses.</p> </div> <hr/> <div data-bbox="623 1648 721 1736" data-label="Image"> </div> <div data-bbox="760 1682 1414 1709" data-label="Text"> <p>The filter does not apply to the Domain-Controlled address.</p> </div> <hr/> <div data-bbox="584 1782 1367 1810" data-label="Text"> <p>Select +, from the <i>Select Entries</i> list, select addresses, and click <i>Close</i>.</p> </div>



Use the search bar to look up an address.



Click the delete icon to delete all the addresses and reset the list.

Note:

The option is disabled by default and only available when editing a secret that has one of its fields set as *Domain*.

Dependency

Select + to add a dependency updater.

The secret is used as the credential for the selected target where the service defined in the selected dependency updater runs.



You can add additional dependency updaters by selecting +.



Once the secret password changer successfully rotates the secret password, all the dependencies in the secret are automatically updated.

The following status messages are used:

- `init`: The dependency is newly added or reset by a configuration change.
- `pending`: The dependency is in progress of checking/updating.
- `success`: When *Check* or *Update* succeeds.
- `failure`: When *Check* or *Update* fails.
- `last-update`: The date and time when the latest update or check occurred.

See [Updating a service account credential Example on page 168](#).

See [Dependency updater on page 166](#).

Dependency





From the dropdown, select a dependency updater.

To create a new dependency updater:

1. From the dropdown, select +.
The *New Dependency Updater* window opens.
2. Follow instructions from step 3 in [Creating a dependency updater on page 167](#) to create a dependency updater.



Use the search bar to look up a dependency updater.

Target		Use the pen icon next to a dependency updater to edit it.
	From the dropdown, select a target where the service defined in the selected dependency updater is running.	
		The target must contain a privileged account.
	<p>To create a target:</p> <ol style="list-style-type: none"> From the dropdown, select +. The <i>New Secret Target</i> window opens. Follow the instructions from step 4 in Creating a target on page 93. 	
		Use the search bar to look up a target.
		Use the pen icon next to a target to edit it.

7. Click *Submit*.



See [Launching a secret on page 82](#) and [Example secret configurations example on page 89](#).

User Permission

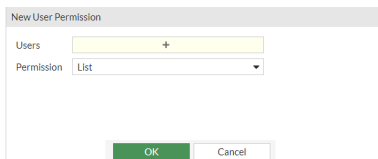
1. In step 5 when [Creating a secret](#), select *Create* in *User Permission*.
The *New User Permission* window opens.



2. Enter the following information:

Users	<p>Select + and from the list, select users in the <i>Select Entries</i> window.</p> <p>To add a new user:</p> <ol style="list-style-type: none"> From the <i>Select Entries</i> window, select <i>Create</i> and then select <i>+User List</i>. The <i>New User List</i> wizard opens. Follow the steps in Creating a user on page 218, starting step 2 to create a new user. <hr/> <div style="display: flex; align-items: center;">  <p>Use the search bar to look up a user.</p> </div> <hr/> <div style="display: flex; align-items: center;">  <p>Use the pen icon next to a user to edit it.</p> </div>
Permission	<p>From the dropdown, select an option:</p> <ul style="list-style-type: none"> <i>None</i>: No access. <i>List</i>: Ability to list secrets. You cannot see detailed information on secrets. <i>View</i>: Ability to view secret details and launch a secret. <i>Edit</i>: Ability to create/edit secrets and launch the secrets. <i>Owner</i>: The highest possible permission level with the ability to create, edit, delete, and launch secrets.

3. Click *OK*.



From the list, select a user permission entry and then select *Edit* to edit it.
 From the list, select user permission entries and then select *Delete* to delete them.

Group Permission

1. In step 5 when [Creating a secret](#), select *Create* in *Group Permission*. The *New Group Permission* window opens.

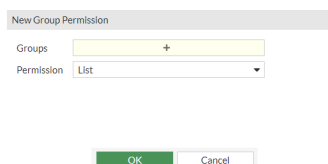

2. Enter the following information:

Groups

Select + and from the list, select user groups in the *Select Entries* window.

To add a new user group:

1. From the *Select Entries* window, select *Create*.
The *Create New User Group* window opens.
2. Follow the steps in [Creating user groups](#), starting step 3.



Use the search bar to look up a user group.



Use the pen icon next to a user group to edit it.

Permission

From the dropdown, select an option:

- *None*: No access.
- *List*: Ability to list secrets. You cannot see detailed information on secrets.
- *View*: Ability to view secret details and launch a secret.
- *Edit*: Ability to create/edit secrets and launch the secrets.
- *Owner*: The highest possible permission level with the ability to create, edit, delete, and launch secrets.

3. Click *OK*.

From the list, select a user group permission entry and then select *Edit* to edit it.

From the list, select user group permission entries and then select *Delete* to delete them.

Installing CA certificates for web launching

When you attempt to access a website using the web proxy feature, you may receive a warning about untrusted hosts on the web browser. To resolve this issue, you must download and install a CA certificate signed by FortiPAM.

When creating a secret with *Web Proxy* enabled, *Download CA Certificate* button on the top-right allows you to download the CA certificate.

The browser may warn untrusted sites even if its certificate is valid. This is because the traffic is proxied by FortiPAM in the proxy mode. Download and install the CA certificate from FortiPAM to resolve the false positive untrusted site warning.

During installation, you may be asked to specify the certificate store (trusted root CA/intermediate CA). Most platforms can automatically select a certificate store based on the type of certificate. You can also specify a location for the certificate manually. For the latter case, check the *Issued to* and *Issued by* fields in the *General* tab of the *Certificate* dialog. If they are the same, choose *Trusted Root Certification Authorities*. If different, select *Intermediate Certification Authorities*.



- Even if the site is trusted before, you must install the FortiPAM CA certificate to resolve the false positive untrusted site warning.
- If the site is untrusted, you receive the warning about untrusted hosts on the web browser.

Download the certificate file, double-click it, and follow the wizard to install it.

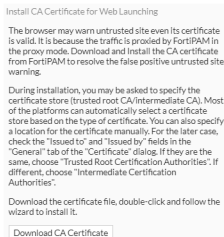

Also, when there are multiple certificates that you need to install, a *Download All CA Certificates* button is available instead.

When downloading multiple certificates, they are made available as a zip file named `CA-Certificates.zip`.



Download and double-click the certificate file to install it by following the installation wizard.

If the CA certificate is root, it must be installed in the trusted root store.

Not all CA certificates should be installed as root CA. If the CA certificate is intermediate, it must be installed in the intermediate store to work correctly.

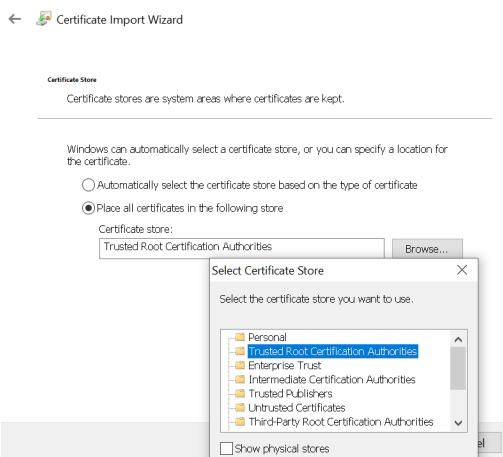

You can tell the CA type by inspecting the property of the CA, e.g., in Windows, right-click the certificate file and click *Property*. If the *Issued to* and *Issued by* fields are the same, it should be installed as a root CA. Otherwise, it is an intermediate certificate and must be installed in the intermediate store.

Also, Windows can automatically determine the correct CA certificate when you select *Automatically select the certificate store based on the type of certificate*. This is the preferred way of certificate installation.

Configuring TOTP settings via the secret CLI commands - Example

To configure TOTP settings via the CLI:

1. In the CLI console, enter the following commands to use the secret template TOTP settings for the secret:

```
config secret database
  edit 1
    config totp-setting
      set status enable
      set use-template-setting enable
      set shared-key xxxxxxxxxxxx
    end
  end
```

To configure TOTP settings via the CLI:

1. In the CLI console, enter the following commands to disable the secret template TOTP settings and instead configure a custom TOTP setting for the secret:

```
config secret database
  edit 1
    config totp-setting
      set status enable
      set use-template-setting disable
      set totp-length 6
      set totp-duration 30
      set hash-type hmac-sha1
      set shared-key xxxxxxxxxxxx
    end
  end
```

Configuring a secret where the secret owner can bypass the SSH command filter via the CLI- Example

To configure the secret via the CLI:

1. In the CLI console, enter the following commands:

```
config secret database
  edit 16
    set name "test_SSH_filter"
    set uuid be0204d2-6ea0-51ee-beb9-e0bd958f624c
    set folder 2
    set template "Unix Account (SSH Password)"
    set proxy enable
    set ssh-filter enable #enable SSH filter
    set ssh-filter-profile "test_SSH_filter" #assign an SSH filter
    set bypass-ssh-filter-for-owner enable #enable allowing secret owners to bypass the
SSH command filter
    set ssh-service-status up
    set rdp-serice-status up
    set sftp-service-status up
    config credentials-history
  end
config field
```

```
edit 1
  set name "Host"
  set value "en.wikipedia.org"
next
edit 2
  set name "Username"
  set value "admin"
next
edit 3
  set name "Password"
  set value "ENC jdiQCaM/yseJywRX+yz0J+xfA2A="
next
end
next
end
```

Configuring a secret to use dependency via the CLI - Example

To configure a secret to use dependency via the CLI:

1. In the CLI console, enter the following commands:

```
config secret database
edit 3
  config dependency
  set target "machine-1174"
  set updater "win-mysql-updater"
  set status init
  set last-update 0000-00-00 00:00:00
end
next
end
```

MySQL service is running on `machine-1174` that uses the credentials from secret 3.

Viewing secret edit history



You must have *View Secret Log* permission to view the secret edit history. See [Role on page 243](#).



You must have at least *View* permission for the secret to see the *Edit History* tab.

To view secret edit history:

1. Go to *Secrets > Secret List* and double-click a secret to edit it.
The *Secret Details* page opens.

2. Select *Edit History* to open the *Edit History* tab.

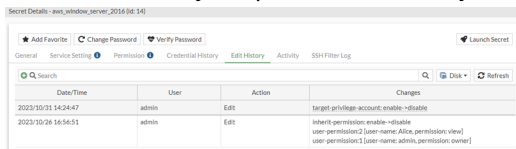

For each edit history, the following columns are displayed by default:

- *Date/Time*
- *User*
- *Action*
- *Changes*



The *Message* column is not visible by default. To display the *Message* column, select *Configure Table* icon as you click the header for the left-most column, select *Message* and then click *Apply*.

The following options are available in the *Edit History* tab:

Search	Enter a search term in the search field, then hit Enter to search. To narrow down your search, see Column filter .
Disk/FortiAnalyzer	From the dropdown, select from the following two options to retrieve the edit history from: <ul style="list-style-type: none"> • <i>Disk</i> (default) (FortiPAM) • <i>FortiAnalyzer</i>
Refresh	To refresh the contents, click the refresh icon.

Viewing secret activity



You must have *View Secret Log* permission to view secret activity. See [Role](#) on page 243.



You must have at least *View* permission for the secret to see the *Activity* tab.

To view secret activity:

1. Go to *Secrets > Secret List* and double-click a secret to edit it. The *Secret Details* page opens.

2. Select *Activity* to open the *Activity* tab.

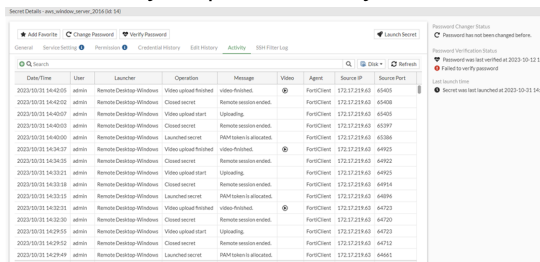

For each activity entry, the following columns are displayed:

- *Date/Time*
- *User*
- *Launcher*
- *Operation*
- *Message*
- *Video*
- *Agent*
- *Source IP*
- *Source Port*

The following options are available in the *Activity* tab:

Search	Enter a search term in the search field, then hit <code>Enter</code> to search. To narrow down your search, see Column filter .
Disk/FortiAnalyzer	From the dropdown, select from the following two options to retrieve the secret activity from: <ul style="list-style-type: none"> • <i>Disk</i> (default) (FortiPAM) • <i>FortiAnalyzer</i>
Refresh	To refresh the contents, click the refresh icon.

Viewing SSH filter logs for a secret



You must have *View Secret Log* permission to view SSH filter logs for a secret. See [Role on page 243](#).



You must have at least *View* permission for the secret to see the *SSH Filter Log* tab.

To view SSH filter logs for a secret:

1. Go to *Secrets > Secret List* and double-click a secret to edit it. The *Secret Details* page opens.

2. Select *SSH Filter Log* to open the *SSH Filter Log* tab.

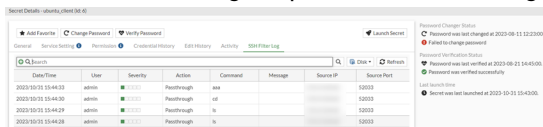

For each entry, the following tabs columns are displayed:

- *Date/Time*
- *User*
- *Severity*
- *Action*
- *Command*
- *Message*
- *Source IP*
- *Source Port*

The following options are available in the *SSH Filter Log* tab:

Search	Enter a search term in the search field, then hit Enter to search. To narrow down your search, see Column filter .
Disk/FortiAnalyzer	From the dropdown, select from the following two options to retrieve the SSH filter logs from: <ul style="list-style-type: none"> • <i>Disk</i> (default) (FortiPAM) • <i>FortiAnalyzer</i>
Refresh	To refresh the contents, click the refresh icon.

Launching a secret

To launch a secret:

1. Go to *Secrets > Secret List*.
2. In the *Secrets List*, double-click a secret to open.
Alternatively, in *Secrets > Personal Folder/Public Folder*, go to the folder where the secret is located, and double-click the secret to open.



If the secret does not show up, it may be because you do not have the necessary permission to access the secret or the folder where the secret is located.

3. Click *Launch Secret*.
The *Launch Progress* window opens.
4. From the list, select a launcher, and select *Launch*.



Chrome, Edge and Firefox have extensions to support video recording for browser based launchers.



AWS does not work with *Web SSH*.

When using file launchers, the following two security features can be enabled in a secret:

Note: Examples of a file launcher include WinSCP, Web SMB, and Web SFTP.

- a. By assigning an antivirus profile to a secret, the user can be protected from downloading viruses and the server can be protected from virus being uploaded. See the *Antivirus Scan* option in [Creating a policy on page 157](#) and [Creating a secret on page 60](#). Also, see [AntiVirus on page 192](#).
 - b. By assigning a DLP sensor to a secret, the server can be protected from sensitive information being uploaded and downloaded from the server. See [Data loss prevention \(DLP\) protection for secrets on page 195](#).
5. After the session is finished, close the launcher.

See [Check out and check in a secret on page 83](#).

Blocklist and allowlist for RDP target IP address restriction

When launching a secret with the *Windows Domain Account* template, you can input any IP address as the target secret.

Blocklist and allowlist can help you to improve security by allowing preconfigured IP addresses.

See the *Target Filter* option in the *Permission* pane when [Creating a secret on page 60](#).

Check out and check in a secret

Checking out a secret gives you exclusive access to the secret for a limited time.

Checking in a secret allows other approved users to access the secret.

To check out a secret:

1. Go to *Secrets > Secret List*.
2. In *Secrets List*, double-click a secret to open.
Alternatively, in *Folders*, go to the folder where the secret is located, and double-click the secret to open.



If the secret does not show up, it may be because you do not have the necessary permission to access the secret or the folder where the secret is located.

3. On the top-right, click *Check-out Secret* to check out the secret.



If the *Check-out Secret* button does not show up, it may be because another user has checked out the secret. At a given time, only one user can check out a secret. Other approved users must wait for the secret to be checked in or wait for the checkout duration to lapse before accessing the secret.

See *Requires Checkout* option when [Creating a secret on page 60](#).



To ensure accountability, a secret password is only visible to the user with *Edit* or *Owner* permission for the secret the user is checking out.

This is only valid when *Requires Checkout* is enabled in the *Secret Setting* pane when configuring the secret.

See *Requires Checkout* option when [Creating a secret on page 60](#).

To check in a secret:

1. Go to *Secrets > Secret List*.
2. In *Secrets List*, double-click a secret to open.
Alternatively, in *Folders*, go to the folder where the secret is located, and double-click the secret to open.
3. On the top-right, click *Check-in Secret* to check in the secret.
Other approved users can now access the secret.

Uploading secrets using the secret upload template

On the *Secret List* page, the uploading secrets feature provides a convenient and faster way to import multiple secrets to FortiPAM at once. You first download the secret upload file template from FortiPAM, input secret-related information such as *Secret Template*, *Target Address*, *Account Name*, and *Account Password* into the file, and then import the file to FortiPAM. All the secrets in the file are added to FortiPAM automatically.

To upload secrets using the secret upload template:

1. Go to *Secrets > Secret List* and select *Upload*.
The *Upload Secret* dialog opens.

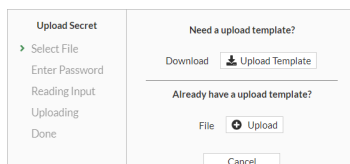

2. Select *Upload Template* to download the secret upload template.
The *Download Template* dialog opens.

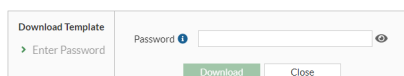

3. In *Password*, enter a password to encrypt the secret upload template excel file.
The secret upload template is downloaded on your computer. The file is named `fpam_secret`.
4. Open the secret upload template (`fpam_secret.xlsx`), enter the password that was used to encrypt the file in step 3, and click *OK*.
You can now access the secret upload template.

The secret upload template currently includes the following features:

- Checks template completion when you quit; a warning appears if the template is incomplete.
 - Highlights fields that need to be filled in.
 - Checks the target address syntax. Currently supports IPv4 addresses and FQDN only.
5. Upon opening the `fpam_secret` file for the first time, enable editing and content for Macros.

- From the *Secret Template* column, select a supported template.



All the default secret templates are supported.



You can create custom secret templates in the secret upload template file by selecting *Customized* from the *Secret Template* column.

- Fill in the fields highlighted in yellow.



The fields highlighted in red cannot be edited.

- Save the file as `.xlsx`(Excel workbook) or a `.csv`(Comma delimited) file on your computer.
- In the *Upload Secret* dialog, select *Upload*, locate the secret upload template file and click *Open*.
- In *Password*, enter the password set in step 3 to decrypt the secret upload template, and click *Next*. Once the secret upload template file is successfully uploaded, *All secrets in the file have been uploaded* message displays.

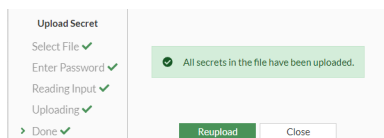

- Click *Close*.
- To refresh the secret list, select *Reload Now* from the message that appears on the bottom-right.



Any failed rows will be displayed in *Upload Secret*, and detailed information can be downloaded by clicking *Download*.

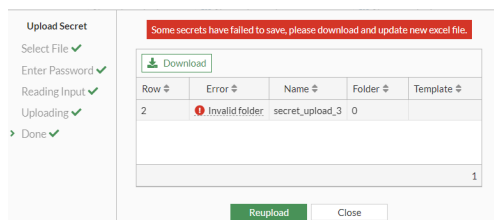

Change password

FortiPAM allows you to manually change the password in a secret.



You can only manually change the passwords every 30 seconds.



You can also set up a secret to automatically change the password by enabling *Automatic Password Changing* when creating or editing a secret.
 See [Automatic password changing on page 187](#).

To change the password:

1. Go to *Secret > Secret List*.
2. In *Secret List*, select a secret, and select *Edit*.
 Alternatively, in *Secrets > Personal Folder/Public Folder*, select the folder where the secret is located, and double-click the secret.

The *Secret Details* window opens.

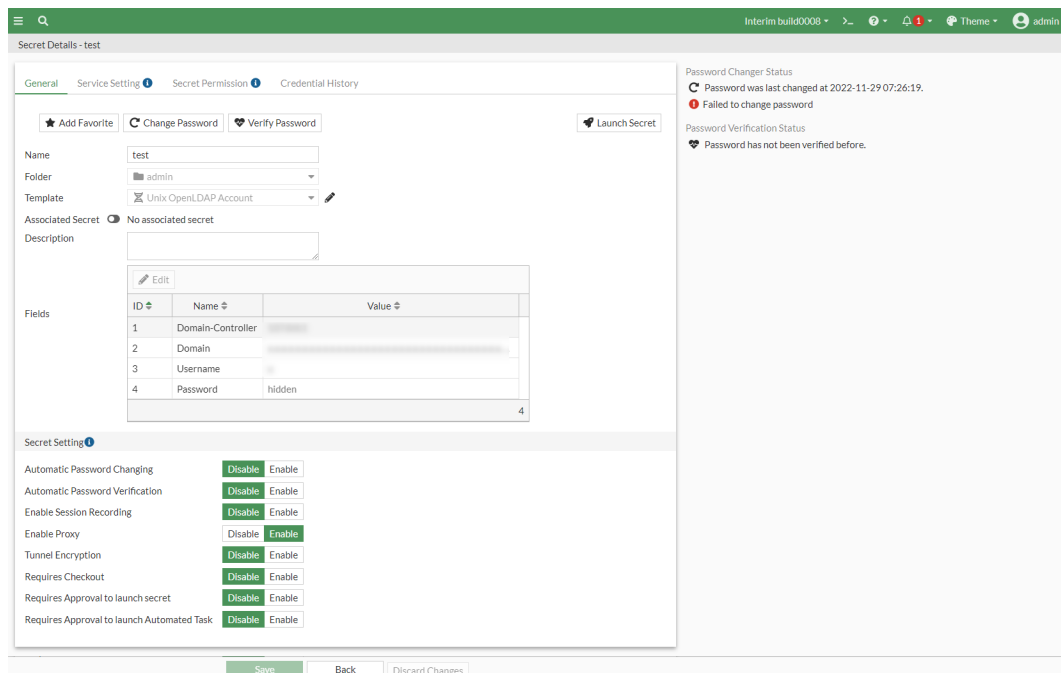

3. From the top, select *Change Password* to change the password.
4. In *Generate next password*, select from the following two options:
 - *Randomly*: automatically change the password.
 - *Customized*: enter a new password manually.

Note: The *Customized* option may be disabled if the secret template does not use password for authentication.



To be able to successfully change the password manually, the password must follow password requirements set in [Password policies on page 188](#).

5. If the password changer failed to change the password last time, it reuses the previously attempted password if it has not been reset.
 In *Reuse attempted password*, select *Yes* to reuse the last attempted password that failed or select *No* to generate a new password.

If you selected *No* in *Reuse attempted password*, select *Randomly* to generate a new password automatically or select *Customized* to enter the password manually.

6. Click OK.

Once the password has changed, *Password Changer Status* shows the date and time when the password was changed and its status.

When using a password changer on Windows AD by LDAPs, it is required to enable both *Change password* and *Reset password* for the user on Windows AD.

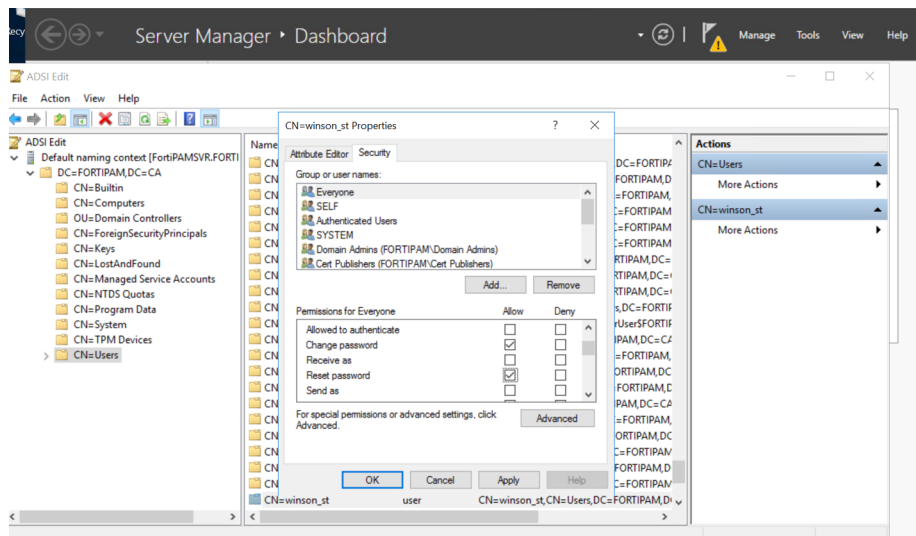

Credential History

FortiPAM retains recent five credentials that have been used by the secret before. These credentials appear in the *Credential History* tab in the secret page. If the last password change failed, FortiPAM retains the last credential that was tried. You can use the credential history to restore the secret password if the credential on the remote server and FortiPAM are out of sync.

When editing a secret, go to the *Credential History* tab to see a history of changes made to the password.

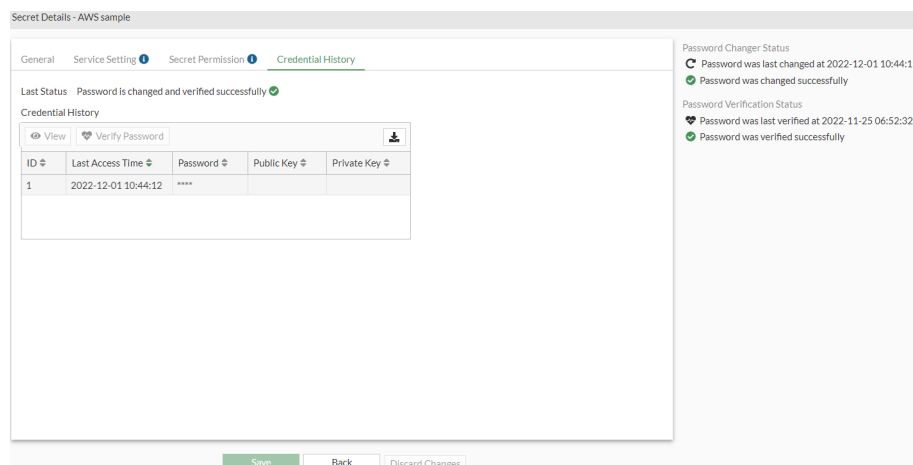

To view previous credentials:

1. Go to *Secrets > Secret List*.
2. In *Secret List*, select a secret, and select *Edit*.
Alternatively, in *Secrets > Personal Folder/Public Folder*, select the folder where the secret is located, and double-click the secret.
The *Secret Details* window opens.
3. Go to the *Credential History* tab.
4. To view the last credential used from a failed password change, click *View Last Credential* to show the password/private key in clear text.
To view the credentials that have previously been successful, click the entry row to view and then click *View* to show the password/private key in clear text.
To clear the last credential used in a failed password change, click *Clear Last Credential*. The last credential used is removed from the credential history.

To restore password using credential history:

1. Go to *Secrets > Secret List*.
2. In *Secret List*, select a secret, and select *Edit*.
Alternatively, in *Secrets > Personal Folder/Public Folder*, select the folder where the secret is located, and double-click the secret.
The *Secret Details* window opens.
3. Go to the *Credential History* tab.
4. To use the last credential from a failed password change, click *Verify Last Credential*.
If the password change is successful, a message shows up asking if you want to restore the credential. Click *Yes* to restore the credential.
To use a previous entry, click the entry row to use and click *Verify Password*. A message appears if the password change is successful.

To configure Windows to allow FortiPAM to change its local user password by SAMBA:

1. On Windows, open *Local Security Policy*.
2. Go to *Local Policies > Security Options > Network access: Restrict clients allowed to make remote calls to SAM*.
3. Right-click *Network access: Restrict clients allowed to make remote calls to SAM* and select *Properties*.
4. Select *Edit Security...*
5. Add users to *Group or user names*: in the *Security Settings for Remote Access to SAM* window.
6. Click *OK*.
7. Click *OK*.

Verify password

On FortiPAM, you can verify the password in a secret manually to check its accuracy, and confirm if the target server is reachable.



You can only manually verify passwords every 5 seconds.



You can also set up a secret to automatically verify the password by enabling *Automatic Password Verification* when creating or editing a secret.

See [Automatic password verification on page 188](#).

To verify the password:

1. Go to *Secrets > Secret List*.
2. In *Secret List*, select a secret, and select *Edit*.
Alternatively, go to *Folders*, and select the folder where the secret is located, and double-click the secret.
The *Secret Details* window opens.

The screenshot shows the 'Secret Details' window for a secret named 'test'. The window is divided into several sections:

- General:** Name: test, Folder: admin, Template: Unix OpenLDAP Account, Associated Secret: No associated secret, Description: (empty).
- Fields:** A table with 4 columns: ID, Name, Value, and a small number in the bottom right corner. The rows are:

ID	Name	Value	
1	Domain-Controller	[Redacted]	
2	Domain	[Redacted]	
3	Username	[Redacted]	
4	Password	hidden	4
- Secret Setting:** A list of settings with 'Disable' and 'Enable' buttons:
 - Automatic Password Changing: Disable (green), Enable (grey)
 - Automatic Password Verification: Disable (green), Enable (grey)
 - Enable Session Recording: Disable (green), Enable (grey)
 - Enable Proxy: Disable (green), Enable (grey)
 - Tunnel Encryption: Disable (green), Enable (grey)
 - Requires Checkout: Disable (green), Enable (grey)
 - Requires Approval to launch secret: Disable (green), Enable (grey)
 - Requires Approval to launch Automated Task: Disable (green), Enable (grey)
- Right Panel:** Password Changer Status: Password was last changed at 2022-11-29 07:26:19. Failed to change password. Password Verification Status: Password has not been verified before.
- Buttons:** Add Favorite, Change Password, Verify Password, Launch Secret, Save, Back, Discard Changes.

3. From the top, select *Verify Password*.
Once the password has been verified, *Password Verification Status* shows the date and time when the password was verified and its status.

Example secret configurations - example

To configure an SSH password:

1. Go to *Secrets > Secret List*.
2. In *Secret List*, select *Create*.
The *Create New Secret in:* dialog appears.
3. Select the folder where you intend to add the secret.
4. Select *Create Secret*.
The *New Secret window* opens.
5. Enter a secret name.
6. In the *Template* dropdown, select *Unix Account (SSH Password)* default template.

7. In *Fields*, enter information for the following fields:
 - a. *Host*
 - b. *Username*
 - c. *Password*
8. Click *Submit*.

To configure an SSH key:

1. Repeat steps 1 to 4 as shown in [Configuring an SSH password](#).
2. Enter a secret name.
3. In the *Template* dropdown, select *Unix Account (SSH Key)* default template.
4. In *Fields*, enter information for the following fields:
 - a. *Host*
 - b. *Username*
 - c. *Public-key* and *Private-key*:
 Select from the following three options:
 - Upload a key file by selecting *File Upload* and then click *Upload* to locate and upload the key file from your computer.
 - Select *Text* and enter the public key in the space below.
 - Select *Generate* and then select a type of encryption algorithm (*RSA*, *DSA*, *ECDSA*, and *ED25519*) and number of *Bits* to use in the auto-generated key-pair.



When *ED25519* is selected as the encryption algorithm, *Bits* are not required.



Using the auto-generated key-pair clears out any existing key-pair.

- d. *Passphrase*, if any.
5. Ensure that proxy is enabled in the *Secret Setting* pane.



An SSH key can only be launched when the secret has *Enable Proxy* checked.

6. Click *Submit*.
 If using an AWS-VM, ensure that *RSA Sign Algorithm* is set to *RSA SHA-256 signing algorithm* in the *Service Setting* tab.

To configure a Windows AD-LDAP secret:

1. Repeat steps 1 to 4 as shown in [Configuring an SSH password](#).
2. Enter a secret name.
3. In the *Template* dropdown, select *Windows Domain Account* default template.

4. In *Fields*, enter information for the following fields:
 - a. *Domain-Controller*
 - b. *Domain*
 - c. *Username*
 - d. *Password*
5. Click *Submit*.

To configure Windows Samba secret:

1. Repeat steps 1 to 4 as shown in [Configuring an SSH password](#).
2. Enter a secret name.
3. In the *Template* dropdown, select *Windows Domain Account(Samba)*.
4. In *Fields*, enter information for the following fields:
 - a. *Domain-Controller*
 - b. *Domain*
 - c. *Username*
 - d. *Password*
5. Click *Submit*.

To configure a Cisco secret:

1. Repeat steps 1 to 4 as shown in [Configuring an SSH password](#).
2. Enter a secret name.
3. In the *Template* dropdown, select *Cisco User (SSH Secret)*.
4. In *Fields*, enter information for the following fields:
 - a. *Host*
 - b. *Username*
 - c. *Password*
5. Click *Submit*.
 If the password change feature needs to be used, then one more secret needs to be created for the Cisco enable command:
 - a. Repeat steps 1 and 2.
 - b. In the *Template* dropdown, select *Cisco Enable Secret*.
 - c. In *Fields*, enter information for the following fields:
 - i. *Host*
 - ii. *Password*
 - d. Click *Submit*.
6. Go to the *Service Setting* tab for the Cisco secret that was earlier created (steps 1 - 5).
7. Optionally, enable *SSH Auto-Password*.
8. Go to the *General* tab, and ensure that *Associated Secret* is enabled.
9. In the *Associated Secret* dropdown, select the Cisco enable secret.
10. Click *Save*.

To configure an AWS web account secret:

1. Repeat steps 1 to 4 as shown in [Configuring an SSH password](#).
2. Enter a secret name.

3. In the *Template* dropdown, select *AWS Web Account*.
4. In *Fields*, enter information for the following fields:
 - a. *URL*
 - b. *Username*
 - c. *Password*
 - d. *AccountID*: Used for IAM accounts.
For AWS root accounts, the field remains empty. Otherwise, the web extension treats the secret as an IAM account secret impacting the login process.
5. Click *Submit*.

Target list

Go to *Secrets > Target List* to create targets.

A target is a server/device with a privileged account supporting RDP, SSH, Web, or other admin protocols. Target systems include Windows workstation, Windows domain controller, Web server, Unix server, SQL- server, router, or firewall.

You can create targets for the secrets stored in FortiPAM. One target can be used for multiple secrets, if appropriate.

For each target; name, host, default template, and web proxy are displayed.

Name	Host	Default Template	Web Proxy
Cloud Platform			
test-2		HeidiSQL	Disable
ESXi			
test_target_no_web_proxy		ESXi Web	Disable
test		HeidiSQL	Disable
Hotmail			
test_web_proxy		ESXi Web	Enable
test_web_proxy_1		ESXi Web	Enable

The *Target List* tab contains the following options:

+Create	Select to create a target. See Creating a target on page 93 .
Search	Enter a search term in the search field, then hit <code>Enter</code> to search the target list. To narrow down your search, see Column filter .
Edit	Select to edit the selected targets.
List Secrets	Select to list the secrets that are using the selected target.
Delete	Select to delete the selected targets.

Creating a target

To create a secret target:

1. Go to *Secrets > Target List*.
2. Select *+Create*.

The *New Secret Target* window opens to the *General* tab.

3. Select *Permission* from the top to switch to the *Permission* tab.

4. Enter the following information:

General	
Name	Name of the target.
Classification Tag	From the dropdown, select a classification tag.
Default Template	<p>From the dropdown, select a secret template.</p> <p>The secret template must include a <i>Target-Address</i>, <i>Domain</i>, or <i>URL</i> field to be included in the dropdown list.</p> <hr/> <div style="display: flex; align-items: center;"> <p>If the <i>Default Template</i> is changed after the target has been assigned to a secret, the <i>Template</i> will not change in the secret. The related secret(s) must be updated, as needed. See Creating a secret on page 60.</p> </div> <hr/>
Gateway	<p>From the dropdown, select a gateway (default = <i>None</i>).</p> <p>A gateway, e.g., a FortiGate or a FortiProxy device, is used when a target is not reachable directly from FortiPAM. It allows you to proxy the connection to the target. See Gateway on page 100.</p> <hr/> <div style="display: flex; align-items: center;"> <p>Use the search bar to look up a gateway.</p> </div> <hr/>
Target-Address	The target address.

This option is only available when the *Target-Address* field type is included in the selected *Default Template*. If the field is mandatory, it must be included when configuring the target.

Domain

The domain for the server.

This option is only available when the *Domain* field type is included in the selected *Default Template*. If the field is mandatory, it must be included when configuring the target.

Common Name

The user ID in the LDAP server. The default is `sAMAccountName`.

This option is only available after entering a *Domain*.

DN Search Base

The distinguished name search base in the LDAP server. The default is "CN=users, DC=A, DC=B, DC=C" for A.B.C domain.

This option is only available after entering a *Domain*.

LDAPS Minimum SSL Version

From the dropdown, select the minimum SSL version. The default is *Follow system global setting*.

This option is only available after entering a *Domain*.

LDAPS Port

The server port. The default is `636`.

This option is only available after entering a *Domain*.

WinRM HTTPS

Enable or disable Windows Remote Management (WinRM) over HTTPS.

URL

The URL for the target.

This option is only available when the *URL* field type is included in the selected *Default Template*. If the field is mandatory, it must be included when configuring the target.

Description

A description for the target.

Advanced Web Setting

These settings are only available in the *General* tab when the *URL* option is populated.

The following shows a configured *Advanced Web Setting* pane.

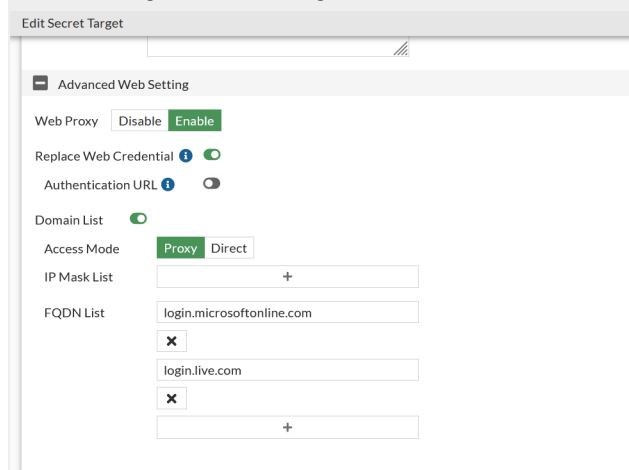

Web Proxy

Enable or disable a web proxy for the target.

When accessing a target using the FortiPAM browser extension, the browser extension sends the browser requests through the FortiPAM web proxy. FortiPAM dynamically operates on the web browser tab's PAC rule (on Google Chrome and Microsoft Edge) to successfully proxy the traffic to FortiPAM based on the configured domain. On Mozilla Firefox, FortiPAM sends the request to the web proxy instead.

FortiPAM scans the incoming web traffic and can replace the password.



Using web proxy, you do not require FortiClient to launch the proxied web account secret.

To enable the web proxy feature, you must first enable the feature globally for the interface that handles incoming and outgoing traffic using the following CLI commands:

```
config system interface
  edit "port1"
    set explicit-web-proxy enable #must be enabled
  next
end
```

Alternatively, you can enable the feature by enabling *Explicit web proxy* for the interface that handles incoming and outgoing traffic. See [Creating an interface on page 309](#).

Notes:

- The option is disabled by default.
- The *Web Proxy* setting is inherited by the secret using the target. See [Creating a secret on page 60](#).

For more information on the web proxy feature, see [Web proxy on page 98](#).

Replace Web Credential	Enable to replace the website authentication credential. Disable to keep the website credential. The default is disabled.
Authentication URL	Enable and enter the website authentication URL. Note: You can enter the authentication URL to prevent deep scanning of all the requests.
Domain List	Enable to create a domain list.
Access Mode	Select <i>Direct</i> or <i>Proxy</i> for the domain access mode.
IP Mask List	Click + to add a domain to the list. Enter the IP mask. Click x to delete a domain from the list.
FQDN List	Click + to add a domain to the list. Enter the fully qualified domain name. Click x to delete a domain from the list.
Permission Access	Target accessible to: <ul style="list-style-type: none"> • <i>Everyone</i>: All users have <i>Read/Write</i> permission for templates (default).

- *Customized*: A user permission and a group permission table must be configured.

User Permission

The level of user access to the template. See [User Permission on page 96](#). The option is only available when *Access* is set to *Customized*. For column settings, see [Tables on page 25](#).

Group Permission



The level of user group access to the template. See [Group Permission on page 97](#). The option is only available when *Access* is set to *Customized*. For column settings, see [Tables on page 25](#).

User Permission

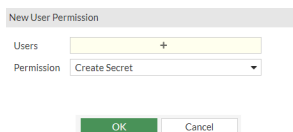
1. When creating a secret target, select *Create* in *User Permission*. The *New User Permission* window opens.



2. Enter the following information:

<p>Users</p>	<p>Select + and from the list, select users in the <i>Select Entries</i> window.</p> <p>To add a new user:</p> <ol style="list-style-type: none"> From the <i>Select Entries</i> window, select <i>Create</i> and then select <i>+User List</i>. The <i>New User List</i> wizard opens. Follow the steps in Creating a user on page 218, starting step 2 to create a new user. <hr/> <p> Use the search bar to look up a user.</p> <hr/> <p> Use the pen icon next to a user to edit it.</p>
<p>Permission</p>	<p>From the dropdown, select an option:</p> <ul style="list-style-type: none"> <i>Create Secret</i>: Ability to see and use the target to create secrets. <i>Owner</i>: The highest possible permission level with the ability to create secrets using the target and to edit and delete the target. <hr/> <p> Every target must have at least one owner.</p>

3. Click *OK*.

<p></p>	<p>From the list, select a user permission entry and then select <i>Edit</i> to edit it.</p> <p>From the list, select user permission entries and then select <i>Delete</i> to delete them.</p>
--	---

Group Permission

1. When creating a secret target, select *Create* in *Group Permission*. The *New Group Permission* window opens.

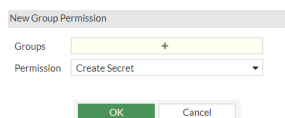

2. Enter the following information:

Groups

Select + and from the list, select user groups in the *Select Entries* window.

To add a new user group:

1. From the *Select Entries* window, select *Create*.
The *Create New User Group* window opens.
2. Follow the steps in [Creating user groups](#), starting step 3.



Use the search bar to look up a user group.



Use the pen icon next to a user group to edit it.

Permission

From the dropdown, select an option:

- *Create Secret*: Ability to see and use the target to create secrets.
- *Owner*: The highest possible permission level with the ability to create secrets using the target and to edit and delete the target.



Every target must have at least one owner.

3. Click *OK*.



From the list, select a user group permission entry and then select *Edit* to edit it.
From the list, select user group permission entries and then select *Delete* to delete them.

Web proxy

When accessing a target using the FortiPAM browser extension, the browser extension now sends the browser requests through the FortiPAM web proxy. This enhances security by not delivering credential information to the client.

FortiPAM offers the web proxy feature to dynamically operate on the web browser tab's PAC rule (on Google Chrome and Microsoft Edge) to successfully proxy the traffic to FortiPAM based on the configured domain. On Mozilla Firefox, FortiPAM sends the request to the web proxy instead.



Fortinet Privileged Access Agent 7.2.3 or above is required to support the web proxy feature.

FortiPAM scans the incoming web traffic and can replace the password.

The web proxy feature is supported on both extension only deployment and extension with FortiClient deployment.

This section describes how the web proxy feature on FortiPAM works:

1. You log in to FortiPAM on a browser and launch a web account secret.
2. The FortiPAM browser extension requests session information from the FortiPAM.
3. FortiPAM returns the following:
 - a. Web account URL
 - b. Web proxy address and the port number
 - c. Proxy sub domains
 - d. Fake password (if *Replace Web Credential* is enabled for the target associated with the secret)
4. The FortiPAM browser extension adds rules for the browsers and sets the proxy address and the port number.
5. The FortiPAM browser extension creates a new tab that opens the URL (target).
6. FortiPAM receives the proxied web traffic and replaces the fake password during authentication.

Password replacement

If the *Authentication URL* is set up, FortiPAM deepscans to see if fake password was used in the request.

If there is no *Authentication URL* set up, FortiPAM checks each request.

FortiPAM stops checking requests once it has detected and replaced the fake password from a request.

Prerequisites

1. You must manually enable `explicit-web-proxy` for the interface that handles incoming and outgoing traffic:

```
config system interface
  edit "port1"
    set explicit-web-proxy enable #must be enabled
  next
end
```

Alternatively, you can enable the feature by enabling *Explicit web proxy* for the interface that handles incoming and outgoing traffic. See [Creating an interface on page 309](#).

2. You must import the related certificate from FortiPAM. Otherwise, the site (target) is not trusted. See [Installing CA certificates for web launching on page 76](#).
3. By default, when using web proxy, port 8080 is the listening port. You can change this using the following CLI commands:

```
config web-proxy explicit-proxy
  edit "web-proxy"
    set status enable
    set interface "any"
    set http-incoming-port 65530 #between 0 - 65535, default = 8080
  next
end
```

4. If the FortiPAM interface cannot be reached from a web browser on Windows as the FortiPAM interface is behind FortiOS, configure a VIP on the FortiOS side to forward to the FortiPAM interface IP and VIP.

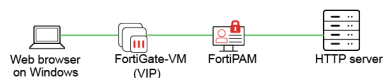

You must add the VIP to your DNS server and give it an FQDN.

On the FortiPAM side, add the FQDN to your web proxy configuration using the following CLI commands:

```
config web-proxy global
  set proxy-fqdn [FQDN of FortiOS VIP]
end
```

5. Ensure that the external interface of the firewall VIP is set to the correct port.

If you are on FortiPAM 1.1.0 or above, setting up the external interface of the firewall VIP to the correct port should be done when setting up FortiPAM:

```
config firewall vip
  edit "fortipam_vip"
  set uuid 7b240e68-fa78-51ed-7846-7536d320d9d3
  set type access-proxy
  set extip 172.16.80.209
  set extintf "port2"
  set server-type https
  set extport 443
  set ssl-certificate "Fortinet_SSL"
next
end
```

See [Configuring the web proxy feature to prevent web credentials from leaking](#) example in the latest *FortiPAM Examples*.

Gateway

Introduction

FortiPAM supports network gateway for distributed target deployment.

Gateway in *Secrets* displays a list of configured gateways.

You can configure a gateway, e.g., a FortiPAM, a FortiGate, or a FortiProxy device, when a target is not reachable directly from FortiPAM to proxy the connection to the target.



Starting FortiOS 7.4.4, FortiPAM gateway is not supported on FortiGate hardware models with 2 GB RAM.



In the above scenario, the FortiPAM deployed on a public site cannot reach the target server directly. The target server is in the private enterprise network and deployable at multiple locations. A FortiGate or a FortiProxy device acts as a network gateway. The network gateway can be applied to the target. All connections to the target are now proxied by FortiPAM and the network gateway.

For each gateway, the following are displayed by default:

- *Name*
- *Status*
- *Address*
- *Port*
- *SSL Max Version*
- *Client Certificate*
- *Remote CA*
- *Reference*

	Name	Status	Address	Port	SSL Max Version	Client Certificate	Remote CA	Reference
<input type="checkbox"/>	FOS_59	Enabled		8443	TLS 1.3	Configured	Not Configured	6
<input type="checkbox"/>	FPX_70	Enabled		443	TLS 1.3	Not Configure	Not Configured	0
<input type="checkbox"/>	Test	Enabled		443	TLS 1.3	Not Configure	Not Configured	0

The *Gateway* tab contains the following options:

Create	Select to create a new gateway. See Creating a gateway on the FortiPAM GUI on page 101 .
Search	Enter a search term in the search field, then hit <code>Enter</code> to search the gateway list. To narrow down your search, see Column filter . The following column filters are available: <ul style="list-style-type: none"> • <i>Name</i> • <i>Status</i> • <i>Address</i> • <i>Port</i> • <i>SSL Max Version</i> • <i>Client Certificate</i> • <i>Remote CA</i> • <i>Reference</i>
Edit	Select to edit the selected gateway.
Delete	Select to delete the selected gateway.

For gateway related CLI configurations, see [Creating a gateway on the FortiPAM CLI on page 102](#) and [FortiPAM connects to a target through a FortiProxy acting as the gateway Example on page 104](#).

Creating a gateway on the FortiPAM GUI

To create a gateway:

1. Go to *Secrets > Gateway*.
2. In the gateway list, *Create*.
The *New Gateway* window opens.

3. Enter the following information:

Name	The name of the gateway.
Status	Enable/disable the gateway (default = <i>Enable</i>).
Address	The gateway IP address or FQDN.
Port	The gateway port number (1 - 65535, default = 443).
SSL Max Version	The highest TLS version acceptable from a server: <ul style="list-style-type: none"> • <i>TLS 1.1</i> • <i>TLS 1.2</i> • <i>TLS 1.3</i> (default) This is the TLS version between FortiPAM and the gateway.
Client Certificate	From the dropdown, select the client certificate for mTLS. This is required if the gateway requests a client certificate.
CA Certificate	From the dropdown, select the CA certificate verification for mTLS. This is used for the gateway certificate verification.
TCP Forwarding Path	The TCP forwarding access proxy path. This is the gateway's URL map for TFAP(TCP Forwarding Application Proxy).
Description	Optionally, enter a description for the gateway.

4. Click *Submit*.

Creating a gateway on the FortiPAM - CLI

FortiPAM now allows configuring a gateway, e.g., a FortiPAM, a FortiGate, or a FortiProxy device, when a target is not reachable directly from FortiPAM to proxy the connection to the target.



To create a gateway:

1. In the CLI console, enter the following commands to configure the gateway:

```
config secret gateway
edit "test1"
set status enable #default value
```

```

set type forward #default value
set address <string>
set port 443 #default value
set sni <string>
set url-map "tcp" #default value
set ssl-max-version tls-1.3 #default value
set client-cert <string>
set ca <string>
set description <string>
next
end

```

Variable	Description
status {enable disable}	Enable/disable the gateway (default = enable).
type forward	The forward connection mode.
address <string>	The gateway IP address or FQDN.
port <integer>	The gateway port number (1 - 65535, default = 443).
sni <string>	The gateway SNI for TLS. If the <code>address</code> is an IP address, the <code>sni</code> is the TLS's SNI extension value, which can be used in the gateway for virtual hosting on the same IP address.
url-map <string>	The TCP forwarding access proxy path. This is the gateway's URL map for TFAP(TCP Forwarding Application Proxy).
ssl-max-version {tls-1.1 tls-1.2 tls-1.3}	The highest TLS version acceptable from a server (default = tls-1.3). This is the TLS version between FortiPAM and the gateway.
client-cert <string>	The client certificate for mTLS. This is required if the gateway requests a client certificate.
ca <string>	The CA certificate verification for mTLS. This is used for the gateway certificate verification.
description <string>	A description for the gateway.

- In the CLI console, enter the following commands to configure a target with gateway:

```

config secret target
edit "172.16.80.101"
set class "Other"
set templete "Unix Account (SSH Password)"
set address <string>
set gateway "test1" #using the gateway created in step 1
set creation-time <datetime> #syntax yyyy-mm-dd hh:mm:ss, year= 2001-2037
set web-proxy-status disable
next
end

```

See [FortiPAM connects to a target through a FortiProxy acting as the gateway Example on page 104](#).

FortiPAM connects to a target through a FortiProxy acting as the gateway - Example

Topology

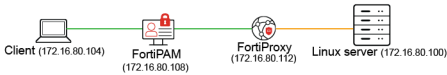

FortiPAM configuration:

1. In the FortiPAM CLI console, enter the following commands to create the FortiProxy gateway:

```
config secret gateway
edit test_gateway
set address "172.16.80.112"
set port 443
set url-map "tcp"
set ssl-max-version tls-1.3
next
end
```

2. In the FortiPAM CLI console, enter the following commands to create the secret target (Linux server):

```
config secret target
edit "172.16.80.100"
set class "Other"
set template "Unix Account (SSH Password)"
set address "172.16.80.100"
set gateway "test_gateway" #from step 1
set creation-time 2023-11-10 09:34:23
set web-proxy-status disable
next
end
```

FortiProxy configuration:

1. In the FortiProxy CLI console, enter the following commands to configure a VIP:

```
config firewall vip
edit "test_vip"
set type access-proxy
set server-type https
set extip 172.16.80.112
set extintf "any"
set h2-support disable
set extport 443
set ssl-certificate "Fortinet_GUI_Server"
set ssl-min-version tls-1.3
next
end
```

2. In the FortiProxy CLI console, enter the following commands to configure an IPv4 access proxy:

```
config firewall access-proxy
edit "test_access_proxy"
set vip "test_vip" #from step 1
set client-cert disable
```

```
set auth-portal enable
config api-gateway
edit 1
  set url-map "/tcp"
  set service tcp-forwarding
config realservers
edit 1
  set address "all"
next
end
next
end
next
end
```

- 3.** In the FortiProxy CLI console, enter the following commands to configure a firewall proxy:

```
config firewall policy
edit 1
  set type access-proxy
  set srcintf "any"
  set srcaddr "all"
  set dstaddr "all"
  set action accept
  set schedule "always"
  set access-proxy "test_access_proxy" #from step 2
next
end
```

Personal/public folder

Folders are the containers of secrets. Folders help you organize customers, computers, regions, and branch offices, etc.



Before you create any secret, you should choose a folder where the secret is added.

You can organize your folders as trees. With folders, granting permissions is simplified as all the secrets in a folder share permissions.

Each folder has different permission to different user or user group. A folder may be set to have one of the following permission:

- **View:** Ability to view secrets and subfolders in a folder.
- **Add:** Ability to create new secrets and subfolders.
- **Edit:** Ability to create/edit secrets, subfolders, and the folder itself.
- **Owner:** The highest possible permission level with the ability to create, edit, delete, and move secrets, subfolders, and the folder itself.

The following shows a folder with secrets in it:

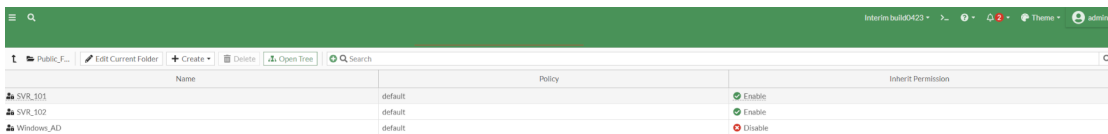

The *Personal Folder/Public Folder* tab in *Secrets* contains the following options:

Go back up one level in the tree	Click to go back up a level in the tree.
Edit Current Folder	Edit the current folder.
Create	From the dropdown, create a secret or a folder. See Creating a secret on page 60 and Creating a folder on page 110 .
Delete	Delete selected subfolders or secrets. See Delete a subfolder or a secret .
Open Tree	Select to open the folder tree. You can use this option to go to a folder. See Opening a folder on page 107 .
Search	Enter a search term in the search field, then hit <code>Enter</code> to search the folders list. To narrow down your search, see Column filter .



Launch Secret, *Make Request*, *Edit* (edit selected folder or secret), *Move*, *Clone* (make a copy of the selected secret), and *Add Favorite* (add secret to the favorite list) options can be found when you right-click a secret or a folder.

Opening a folder



Before opening a folder, ensure that your account has sufficient permission to view folders.

To open a folder:

1. Go to *Secrets > Personal Folder/Public Folder*, and select *Open Tree*.
Alternatively, in the folder list, double-click a folder to open.
2. In the *Open* window, locate the folder you intend to open from the tree.
3. Click *Open*.

Moving a subfolder



Before moving a subfolder, ensure that your account has sufficient permission to move subfolders.

To move a subfolder:

1. Go to *Secrets > Personal Folder/Public Folder*, and select *Open Tree*.
2. In the *Open* window, from the tree, locate the parent folder for the subfolder you intend to move and click *Open*.
3. Right-click the subfolder and select *Move*.
The *Move to* window opens.
4. Select the destination folder from the tree and then select *Move Folder*.

Moving a secret to a different folder



Before moving a secret, ensure that your account has sufficient permission to move secrets.

To move a secret:

1. Go to *Secrets > Personal Folder/Public Folder*, and select *Open Tree*.
2. In the *Open* window, from the tree, locate the folder where the secret resides and click *Open*.
3. Right-click the secret and select *Move*.
The *Move to* window opens.
4. Select the destination folder from the tree and then select *Move Secret*.

Moving multiple secrets to a different folder

To move multiple secrets to a different folder:

1. Go to *Secrets > Personal Folder/ Public Folder*, and select *Open Tree*.
2. In the *Open* dialog, from the tree, locate the folder where the secrets reside and click *Open*.
3. Hold the `ctrl` key as you select the secrets from the folder.
4. Right-click and then select *Move*.
5. In the dialog that appears, locate the target folder where the selected secrets will be moved to, and click *Move Secret*.



If you do not have *Write* permission for the first secret you selected, the *Move* option is disabled.



If some secrets fail to move due to insufficient permissions, select *Click here for more details* to view the list of secrets that failed to move.

Editing a subfolder or a secret:



Before editing a folder or a secret, ensure that your account has sufficient permission to edit folders and secrets.

To edit a subfolder or a secret:

1. Go to *Secrets > Personal Folder/Public Folder*, and select *Open Tree*.
2. In the *Open* window, from the tree, locate the parent folder where the subfolder or the secret resides and click *Open*.



To edit the current folder you are in, select *Edit Current Folder*.

-
3. Right-click a subfolder or secret and then select *Edit*.

The *Edit Secret Folder* or *Secret Details* window opens.

4. Update the options as needed.



The options when editing the folder or a secret are same as when creating a folder or a secret.

See [Creating a folder on page 110](#) and [Creating a secret on page 60](#).

Deleting a subfolder or a secret:



Before deleting a folder or a secret, ensure that your account has sufficient permission to delete folders or secrets.

To delete a subfolder or a secret:

1. Go to *Secrets > Personal Folder/Public Folder*, and select *Open Tree*.
 2. In the *Open* window, from the tree, locate the parent folder where the subfolder or the secret resides and click *Open*.
 3. Right-click a subfolder or secret and then select *Delete*.
The *Confirm* dialog appears.
 4. Select *OK* to delete the selected folder or secret.
-



You can only delete an empty folder.

Adding a favorite secret

To add a favorite secret:

1. Go to *Secrets > Personal Folder/Public Folder*, and select *Open Tree*.
2. In the *Open* window, from the tree, locate the parent folder where the secret resides and click *Open*.
3. Right-click a secret and then select *Add Favorite*.

Removing a secret from favorite

To remove a secret from favorite:

1. Go to *Favorite Secrets* in the tree menu.
 2. In the page that lists favorite secrets, right-click a secret and then select *Remove Favorite* to remove the secret from *Favorite Secrets*.
-



You can now add/remove multiple secrets to/from the favorite list by selecting the secrets, right-clicking on any of the selected secrets, and then selecting either *Add/Remove Favorite*. Alternatively, having selected the secrets, click *Add/remove Favorite* from the top.

Creating a folder

To create a folder:





1. Go to *Secrets > Personal/Public Folder* and select *Open Tree*.
2. In the *Open* window, select where you intend to create a folder.



You can create a folder in an existing folder or select *Folder* from the *Create* dropdown in *Root* to create a root folder.

3. Click *Open*.
4. From the *Create* dropdown, select *Folder*.
The *New Secret Folder* window opens.

5. Enter the following information:

General	
Name	Name of the folder.
Parent Folder	From the dropdown, select a parent folder or select <i>Create</i> to create a new parent folder.
	The parent folder is set in step 2.
	The parent folder cannot be changed for a root folder.
	Use the search bar to look for a folder.
	Use the pen icon next to the folder to edit it.
Inherit Policy	Enable to inherit policy that applies to the parent folder.



The option is enabled by default when creating a subfolder.



You cannot inherit policy for a root folder.

Secret Policy

From the dropdown, select a policy that applies to the folder or select *Create* to create a new policy.

See [Creating a policy on page 157](#).



Use the search bar to look for a policy.



Use the pen icon next to the policy to edit it.



This option is only available when *Inherit Policy* is disabled.

Folder Permission

Use the settings in the pane to control access to the folder.

Inherit ZTNA Control

Enable to inherit ZTNA control access permission from the parent folder.

When configuring a subfolder, FortiPAM displays the ZTNA control settings from the parent folder.

New Secret Folder

General **Permission**

Inherit ZTNA Control

ZTNA Control

Device Tags

Device Match Logic OR AND

Inherit Permission

User Permission

ID	Users	Folder permission	Secret Permission
1	admin	Owner	Owner

Group Permission

ID	Groups	Folder permission	Secret Permission
No results			

Submit Cancel



By default, secrets in a folder follow the ZTNA control set up in the parent folder. However, when creating or editing a secret you can customize the ZTNA control in the *Secret Permission* tab. See [Creating a secret on page 60](#).



The option is enabled by default when creating a subfolder.



You cannot inherit ZTNA control access permission for a root folder.

ZTNA Control

Enable to limit access by `ztna-ems-tag`.

You can choose whether to match all the tags or only one of them.



The option is only available when *Inherit ZTNA Control* is disabled.

Device Tags

Select + to add ZTNA tags or groups.



Use the search bar to look up a ZTNA tag or ZTNA tag group.

Only permitted devices with the selected tags are allowed to launch.

Device Match Logic

Define the match logic for the device tags:

- *OR*: Devices with any of the selected tags are allowed to launch.
- *AND*: Devices must acquire all the selected tags to launch.

Inherit Permission

Enable to inherit permission from the parent folder.



The option is enabled by default when creating a subfolder.



You cannot inherit permission for a root folder.

Note: The setting can only be disabled if you have the *Owner* permission. Also, the setting cannot be disabled for any subfolder of the personal folder, i.e., the folder generated for every user.

User Permission

The level of user access to the folder and secrets in the folder. See [User Permission on page 113](#).



This option is only available when *Inherit Permission* is disabled.

For column settings, see [Tables on page 25](#).

Group Permission

The level of user group access to the folder and secrets in the folder. See [Group Permission on page 114](#).



This option is only available when *Inherit Permission* is disabled.

For column settings, see [Tables on page 25](#).

6. Click *Submit*.

User Permission

To create a user permission:

1. In step 4 when [Creating a folder](#), select *Create* in *User Permission* when *Inherit Permission* is disabled. The *New User Permission* window opens.

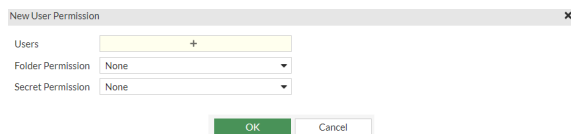

New User Permission

Users

Folder Permission

Secret Permission

2. Enter the following information:

Users

Select + and from the list, select users in the *Select Entries* window.



Use the search bar to look up a user.



Use the pen icon next to the user to edit it.

To add a new user:

1. From the *Select Entries* window, select *Create* and then select *+User List*. The *New User List* wizard opens.
2. Follow the steps in [Creating a user on page 218](#), starting step 2 to create a new user.

Folder Permission

From the dropdown, select an option:

- *None*: No access.
- *View*: Ability to view secrets and subfolders in the folder.
- *Add Secret*: Ability to create new secrets.
- *Edit*: Ability to create/edit secrets, subfolders, and the folder itself.
- *Owner*: The highest possible permission level with the ability to create, edit, delete, and move secrets, subfolders, and the folder itself.

Secret Permission

From the dropdown, select an option:

- *None*: No access.
- *List*: Ability to list secrets. You cannot see detailed information on secrets.
- *View*: Ability to view secret details and launch a secret.
- *Edit*: Ability to create/edit secrets and launch the secrets.
- *Owner*: The highest possible permission level with the ability to create, edit, delete, move, and launch secrets.

3. Click *OK*.



From the list, select a user permission and then select *Edit* to edit the user permission.
From the list, select user permissions and then select *Delete* to delete the user permissions.

Group Permission

To create group permission:

1. In step 4 when [Creating a folder](#), select *Create* in *Group Permission* when *Inherit Permission* is disabled. The *New Group Permission* window opens.



New Group Permission x

Groups

Folder Permission None

Secret Permission None

2. Enter the following information:

Groups	<p>Select + and from the list, select user groups in the <i>Select Entries</i> window.</p> <hr/> <div style="display: flex; align-items: center; gap: 10px;">  <p>Use the search bar to look up a user group.</p> </div> <hr/> <div style="display: flex; align-items: center; gap: 10px;">  <p>Use the pen icon next to the user group to edit it.</p> </div> <hr/> <p>To add a new user group:</p> <ol style="list-style-type: none"> 1. From the <i>Select Entries</i> window, select <i>Create</i>. The <i>Create New User Group</i> window opens. 2. Follow the steps in Creating user groups, starting step 3.
Folder Permission	<p>From the dropdown, select an option:</p> <ul style="list-style-type: none"> • <i>None</i>: No access. • <i>View</i>: Ability to view secrets and subfolders in the folder. • <i>Add Secret</i>: Ability to create new secrets. • <i>Edit</i>: Ability to create/edit secrets, subfolders, and the folder itself. • <i>Owner</i>: The highest possible permission level with the ability to create, edit, delete, and move secrets, subfolders, and the folder itself.
Secret Permission	<p>From the dropdown, select an option:</p> <ul style="list-style-type: none"> • <i>None</i>: No access. • <i>List</i>: Ability to list secrets. You cannot see detailed information on secrets. • <i>View</i>: Ability to view secret details and launch a secret. • <i>Edit</i>: Ability to create/edit secrets and launch the secrets. • <i>Owner</i>: The highest possible permission level with the ability to create, edit, delete, move, and launch secrets.

3. Click *OK*.

	<p>From the list, select a user group permission and then select <i>Edit</i> to edit the user group permission.</p> <p>From the list, select user group permissions and then select <i>Delete</i> to delete the user group permissions.</p>
---	---

My requests list

To launch secrets where approval from the members of the approval group(s) is required, you must send out a request. The request would then be reviewed by the members of the approval group(s), and could be approved or denied by any members of the groups.



Access is granted to the user for only a period of time.

Go to *Secrets > My Request List* to see list of secret requests.

The widgets at the top display:

- The request types and their count.
- The status of the requests and their count.

For every request the following fields are listed:

- *Secret*: Secret name with the request ID.
- *Request Type*
- *Tier Approval Progress*
- *Start Time*
- *Expiration Time*
- *Duration*
- *Creation Time*

The screenshot shows two summary widgets at the top. The first widget, titled 'Request Type', shows a donut chart with 4 total requests, all of which are 'Launcher' type. The second widget, titled 'Availability', shows a donut chart with 4 total requests, all of which are 'Expired'.

Secret	Request Type	Tier Approval Progress	Start Time	Expiration Time	Duration	Creation Time
test#4	Launcher	⊙	2024-02-23 15:10:00	2024-02-23 15:40:00	30 minutes	2024-02-23 15:10:15
test#3	Launcher	⊙	2024-02-23 13:55:00	2024-02-23 14:55:00	1 hour	2024-02-23 13:55:25
test#2	Launcher	⊙	2024-02-23 13:09:00	2024-02-23 13:39:00	30 minutes	2024-02-23 13:09:53
test#1	Launcher	⊙	2024-02-20 13:00:00	2024-02-20 14:00:00	1 hour	2024-02-20 13:00:30



All requests stay in the list until they are deleted.



Hover over a request in the list to see additional information about the secret.



When an approved request's access time is up, the secret session is terminated even though the secret session is still on.

The *My Request List* tab contains the following options:

Create	Select to create a new request. See Make a request on page 117 .
Edit	Select to edit the selected request.
	 When a secret request is approved, the <i>Launcher Status</i> timer shows the remaining time till you (as a requester) have access to the secret when you (as a requester) double-click to open the secret request in <i>Secrets > My Request List</i> .
Delete	Select to delete the selected requests.
Search	Enter a search term in the search field, then hit <code>Enter</code> to search the requests list. To narrow down your search, see Column filter .



Double-click a request to open it and select *Go to Secret* to go to the related secret or select *View Approvers Comments* to view comments from the approvers.

Make a request

To make a request:

1. Go to *Secrets > Secret List*.
2. In the *Secrets List*, double-click a secret to open.

Alternatively, in *Secrets > Personal Folder/Public Folder*, go to the folder where the secret is located, and double-click the secret to open.

You can also go to *Secrets > My Requests List*, select *Create*, and skip to step 4.



If the secret does not show up, it may be because you do not have the necessary permission to access the secret or the folder where the secret is located.

3. On the top-right, click *Make Request* to send out a request to launch the secret.









If the *Make Request* option does not appear, it is because *Requires Approval to Launch Secret* or *Requires Approval to Launch Job* is disabled in the *Secret Setting* pane when creating or editing a secret.

See [Creating a secret on page 60](#).

The *New secret request* window opens.

4. Enter the following information:

Requester	The requester. Note: The option cannot be changed.
Request Type	Select from the following request types: <ul style="list-style-type: none"> • <i>Launcher</i> • <i>Job</i>
Secret	When the <i>Request Type</i> is <i>Launcher</i> , select + and select secrets from the <i>Select Entries</i> list. These are secrets with <i>Requires Approval to Launch Secret</i> enabled. See Creating a secret on page 60 .  If available, hover over the secret to see additional information including the folder where the secret is located and the secret template being used for the secret.  When the <i>Request Type</i> is <i>Launcher</i> , use the search bar to look up a secret with <i>Requires Approval to Launch Secret</i> enabled.
Job	When the <i>Request Type</i> is <i>Job</i> , secret associated with the job is automatically selected. The option becomes non-editable. This is the secret with <i>Requires Approval to Launch Job</i> enabled.  Not all jobs require approval. When editing a secret, the <i>Requires Approval to Launch Job</i> option in the <i>Secret Setting</i> pane determines which jobs require approval. Select + and select jobs from the <i>Select Entries</i> list. Note: The option is only available when the <i>Request Type</i> is <i>Job</i> .
Start Upon Approval	Enable/disable launching a secret once it is approved (default = disable).

	 <p>The approver can still override when you get access to the secret and the duration of time you have access to the secret.</p>
Duration	Specify the duration of time you need the secret access for, in minutes (default = 30, minimum = 1).
	 <p>The option is only available when <i>Start Upon Approval</i> is enabled.</p>
Request Duration	<p>When the <i>Request Type</i> is <i>Launcher</i>, from the dropdown, select a duration of time or select <i>Custom</i> and then enter a date (MM/DD/YYYY) and time range. Alternatively, select the calendar icon and select a start/end date and time.</p> <p>When the <i>Request Type</i> is <i>Job</i>, the start time is the latest scheduled time among all selected jobs. Enter an end date (MM/DD/YYYY) and time.</p>
	 <p>The local time of the requestor is displayed.</p>
Request Comments	Optionally, enter comments for the request.
Status	Current status of the request.

5. Click *Submit*.

Once the request is submitted, it appears in *My Request List* and *Approval List* tab. See [My requests list on page 116](#) and [Approval list on page 119](#).

Reviewers specified in [Approval profile on page 171](#) are sent email notifications so that they can log in to FortiPAM from the email link. If the request is approved or denied, the status of the request changes to *Approved* or *Denied* respectively in *My Request List*.



For the approver's email notification, an approver only receives the notification when the request goes to the corresponding tier where the approver is located.

Approval list

Go to *Secrets > Approval List* to see a list of secret requests for review.

The *Approval List* tab looks like the following:

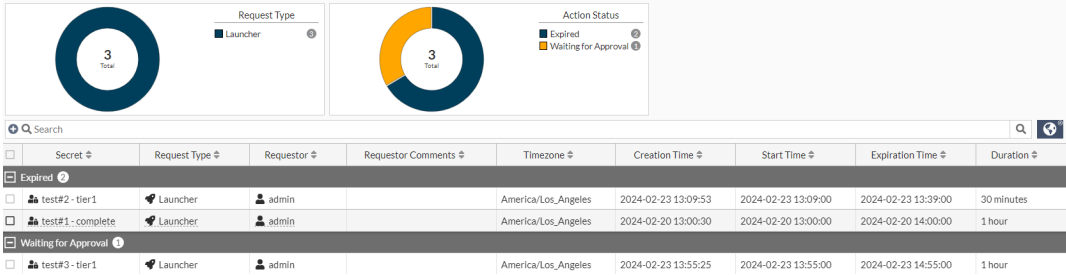

The widgets at the top display:

- The request types and their count.
- The status of the requests and their count.



All requests stay in the list until they are deleted.

For each secret request, the following columns are displayed by default:

- *Secret*
- *Request Type*
- *Requestor*
- *Requestor Comments*
- *Timezone*
- *Creation Time*
- *Start Time*
- *Expiration Time*
- *Duration*

The *Approval List* tab contains the following options:

Search	Enter a search term in the search field, then hit <code>Enter</code> to search the reviews list. To narrow down your search, see Column filter .
Enable/Disable Requestor Timezone (🌐)	Click to enable/disable the secret access requestor's timezone.
Edit	Select a request and then select <i>Edit</i> to approve or deny the selected request. Alternatively, double-click a request to review the request. See Approving a request on page 121 .
	 <p>When a secret request is approved, the <i>Launcher Status</i> timer shows the remaining time till the requester has access to the secret when you (as an approver) double-click to open the reviewed request in <i>Secrets > Approval List</i>.</p>
Approve	Select to approve the selected requests.

See [Reviewing multiple requests on page 122](#).

Deny

Select to deny the selected requests.

See [Reviewing multiple requests on page 122](#).

Approving a request

To approve or deny a secret request:

1. Go to *Secrets > Approval List*, select secret request, and then select *Edit*.
Alternatively, double-click a request to open it.

The *Approving secret request* window opens.

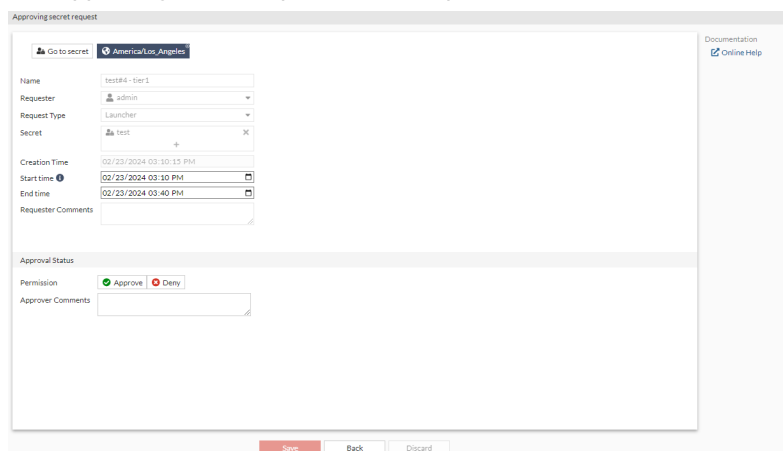

By default, the approver's timezone is used.

Click the *Enable Requestor Timezone* option to enable the requestor's timezone and display the requestor's local time.



In *Start time* and *End time*, select the *Calendar* icon and select a new date and time range to override the requested duration. Alternatively, enter a new date and time range.

2. In the *Approval Status* pane:
 - a. In *Permission*, select *Approve* or *Deny*.
 - b. In *Approver Comments*, enter comments related to the secret request.



Approver comments are visible to the requester.

3. Click **Save**.



Select *Go to secret* to go to the secret.

Before a request is sent to the next tier or is finalized, the approval action can be revoked by the reviewer who approved it.



If the *Request Type* is *Job*, the output of script can be checked in logs.

Once a secret request is approved or denied, the request status appears in the *Approval List* tab and the status is updated in the [My requests list on page 116](#) tab.

If the request is denied, the user can see the reviewer comments.

To see the reviewer comments:

1. Go to *Secrets > My Request List*.
2. Double-click the denied request under *Denied/Expired*.
3. Select *View Approvers Comments* to see the reviewer comment.
Alternatively, go to *Secrets > Approval List*, under *Denied/Expired Request*, double-click the request to see the reviewer comments in the *Approval Status* pane.

Reviewing multiple requests

You can approve/deny multiple secret/job requests together in *Secrets > Approval List*.

To review multiple requests:

1. Go to *Secrets > Approval List*, select multiple secret/job requests from the *Action is required* column, and then select *Approve/Deny*.

The *Please confirm the following approving/denying details* window opens:

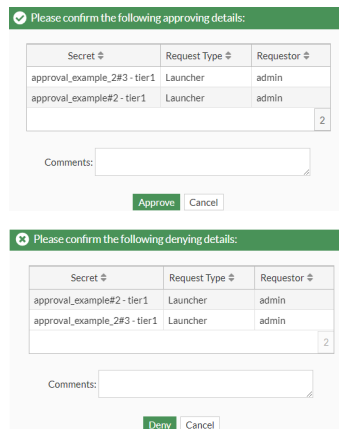

2. From the table, select secret/job requests.

- Optionally, enter comments about the secret/job request.



Approver comments are visible to the requester.

- Click *Approve/Deny*.

Before a request is sent to the next tier or is finalized, the approval action can be revoked by the reviewer who approved it.



If the *Request Type* is *Job*, the output of script can be checked in logs.

Once a secret request is approved or denied, the request status appears in the *Approval List* tab and the status is updated in the [My requests list on page 116](#) tab.

Job list

Go to *Secrets > Job List* to create jobs.

A job is an automated task that executes the predefined script at a scheduled time. It could be a one-time or recursive event.

Jobs in FortiPAM allow you to run scripts. Optionally, you can set up a recurring schedule for this script.

For each job; name, secret, status, execution, type, schedule type, and approval status are displayed.

Name	Secret	Status	Execution	Type	Schedule Type	Approval Status
ssh-script-sample	job_example	Enabled	Not Executed	SSH Script	One-shot	Pending



Jobs are not executed when FortiPAM is in maintenance mode.

The *Job List* tab contains the following options:

+Create	Select to create a job. See Creating a job on page 124 .
Edit	Select to edit the selected job.
Delete	Select to delete the selected jobs.
Search	Enter a search term in the search field, then hit <code>Enter</code> to search the jobs list. To narrow down your search, see Column filter .

Creating a job

To create a job:

1. Go to *Secrets > Job List*.
2. Select *+Create*.





The *New Job* window opens.

The screenshot shows the 'New Job' configuration window. The 'Configurations' section includes the following fields:

- Name: [Empty text box]
- Requester: [admin]
- Type: [SSH Script]
- Status: [Disable] [Enable] (Enable is selected)
- Secret: [Empty dropdown menu]
- Associated Secret: [No associated secret]
- Recursive: [One-time schedule]
- Start Time: [mm/dd/yyyy --:-- --]
- Script: [Empty text area]

At the bottom of the window are 'Submit' and 'Cancel' buttons. On the right side, there is a 'Job' definition: 'A Job is an automated task that executes the predefined script at a scheduled time. It could be a one-time or recursive event.'

3. Enter the following information:

Name	Name of the job.
Requester	From the dropdown, select a requester.
Type	From the dropdown, select from the following two options: <ul style="list-style-type: none"> • <i>SSH Script</i>: targeting secrets that work on linux-like machines (default). • <i>SSH Procedure</i>: targeting secrets that run on SSH server, e.g., FortiGate, Cisco, or Ubuntu.
Status	Enable/disable the execution of the job (default = disable).
Secret	From the dropdown, select a secret or create a new secret. <div style="border-top: 1px solid black; padding: 5px 0;">  Use the search bar to look for a secret. </div> <div style="border-top: 1px solid black; padding: 5px 0;">  Use the pen icon next to a secret to edit it. </div>
Associated Secret	Enable and then from the dropdown, select an associated secret or create a new secret. When enabled, changing password or verifying password requires credentials from the associated secret. Note: The option is disabled by default. <div style="border-top: 1px solid black; padding: 5px 0;">  Use the search bar to look for a secret. </div> <div style="border-top: 1px solid black; padding: 5px 0;">  Use the pen icon next to a secret to edit it. </div>
Recursive	Enable to set up a recurring schedule. Displays the job execution schedule based on your selections for the related settings. Note: The option is disabled by default.
Start Time	The date and time when recurring schedule begins. Enter date (MM/DD/YYYY) and time or select the <i>Calendar</i> icon and then select a date and time.
Recurrence	From the dropdown, select from the following three frequencies of recurrence: <ul style="list-style-type: none"> • <i>Daily</i> • <i>Weekly</i>

	<ul style="list-style-type: none"> • <i>Monthly</i> <p>Note: The option is only available when <i>Recursive</i> is enabled.</p>
Repeat every	<p>The number of days/weeks/months after which the job is executed (1- 400).</p> <p>Note: The option is only available when <i>Recursive</i> is enabled.</p>
Occurs on	<p>Select from the following days of the month when the job is automatically executed:</p> <ul style="list-style-type: none"> • <i>First</i> • <i>Second</i> • <i>Third</i> • <i>Last</i> • <i>Last Day</i> • <i>Day</i> <p>Select days of the week when the job is automatically executed. When you select <i>Day</i>, select + to add days of the month when the job is automatically executed.</p> <p>Note: The option is only available when <i>Recurrence</i> is set as <i>Weekly</i> or <i>Monthly</i>.</p>
Script	Enter the script.

4. Click *Submit*.



When editing a job, select the *Make Request* option from the top to make a request to perform a job on the secret associated with the job. See [Make a request on page 117](#).



When editing a job, select the *Log* tabs to see logs related to the job. See [Log & report on page 277](#).



For a script job type, you can check the result on the *Edit Job* page after the job is executed.

Discovery

Discovery in *Secrets* displays a list of configured discovery entries.

Discovery is the process where FortiPAM scans an environment to find accounts and other associated resources. Once the accounts and the resources are found, they can be automatically imported to FortiPAM for centralized management.

Discovery helps provide a better overview of the existing accounts in an Active Directory. The automatic import feature saves time.



Users with the *Secret Discovery* permission for their role are able to see the *Discovery* tab in *Secrets*.

See [Role](#) on page 243.



Do not use the CLI console to configure discovery.

The following columns are available in the *Discovery* tab:

- *Name*
- *Discovery Secret*
- *Discovered*
- *Periodic Scanning*

	Name #	Discovery Secret #	Discovered #	Periodic Scanning #
<input type="checkbox"/>	Test 2	Windows AD 200-Robert	Discovered	Disable
<input type="checkbox"/>	Test_1	Windows_AD_200-Robert	Discovered	Disable
<input type="checkbox"/>	Discover Windows AD	Windows AD 200-Robert	Discovered	Disable

The *Discovery* tab contains the following options:



Create	Select to create a new discovery entry. See Creating discovery entry on page 127 .
Search	Enter a search term in the search field, then hit <code>Enter</code> to search the discovery list. To narrow down your search, see Column filter .
Edit	Select to edit the selected discovery entry.
Delete	Select to delete the selected discovery entries.
Clear Selection	Select to clear the currently selected discovery entries from selection.

Creating discovery entry

To create a discovery entry:

1. Go to *Secrets > Discovery*.
2. In the *Discovery* tab, select *Create*.
The *New Secret Discovery* tab opens.

3. Enter the following information:

Name	The name of the discovery entry.
Target	<p>From the dropdown, select a target, e.g., a secret target for the Domain Controller.</p> <p>To create a new target:</p> <ol style="list-style-type: none"> From the dropdown, select +. The <i>New Secret Target</i> window opens. Follow the steps in Creating a target on page 93, starting step 4. <hr/> <p> From the search bar look up a target.</p> <hr/> <p> Use the pen icon next to the target to edit it.</p> <hr/>
Secret	<p>From the dropdown, select a secret that is using the selected target to perform discovery.</p> <hr/> <p> The account of the selected secret is used to perform discovery on the selected target. This is generally a privileged account.</p> <hr/> <p>To create a new secret:</p> <ol style="list-style-type: none"> From the dropdown, select +. The <i>New Secret</i> window opens. Follow the steps in Creating a secret on page 60, starting step 6.



From the search bar look up a secret.



Use the pen icon next to the secret to edit it.

LDAP Search Base

Enter the LDAP search base.



Search base denotes the location in the directory where the search for a particular directory object begins, e.g., `CN = Users, DC=FORTINET, DC=COM`.

LDAP Group Filter

Enter the LDAP group filter.



Standard LDAP filters to the LDAP search. Only the accounts that match the specified group filters are discovered, e.g., `(&(memberOf=cn=HR_GRP,cn=users,dc=fortinet,dc=com)(memberOf=cn=DEV_GRP,cn=users,dc=fortinet,dc=com))`.



LDAP Group Filter is an optional configuration. Leave the field empty if you do not want to apply LDAP filters to the search.

Periodic Scanning

Enable/disable periodic scanning (default = disable).



If you disable the setting, you can later manually click *Discover* in the *Edit Secret Discovery* page to trigger discovery.

4. Click *Submit*.

Manual discovery

To perform manual discovery:

1. Go to *Secrets > Discovery*.
2. In the *Discovery* tab, select a discovery entry and then select *Edit*.
The *Edit Secret Discovery* window opens.

3. From the right, click *Discover* to trigger a one-time discovery.
4. In the *Results* tab, you can see the discovered accounts.

Account	Status	Secret	Last Scan Time
<input type="checkbox"/> pam14_k0ap	Managed	Windows AD 200 pam14 k0ap	2024/03/13 10:56:...
<input type="checkbox"/> robert_fac	Unmanaged		2024/03/13 10:56:...
<input type="checkbox"/> pam31_k0ap	Managed	Windows AD 200 pam31 k0ap1111	2024/03/13 10:56:...
<input type="checkbox"/> robert_k0ap3	Managed	Windows_AD_200 robert_k0ap3	2024/03/13 10:56:...
<input type="checkbox"/> robert_k0ap4	Managed	hkh0hkhk	2024/03/13 10:56:...
<input type="checkbox"/> robert_k0ap5	Managed	Windows_AD_200 robert_k0ap5	2024/03/13 10:56:...
<input type="checkbox"/> robert_k0ap6	Unmanaged		2024/03/13 10:56:7

5. Select the unmanaged account and select *Import* to import the selected account as a secret to FortiPAM.



The *Status* of an account indicates if it is managed by FortiPAM:

- *Managed*: Account is managed by FortiPAM.
- *Unmanaged*: Account is not managed by FortiPAM.

If an account is already managed by FortiPAM, you can see the corresponding secret in the *Secret* column.

Double-click a managed account to open the *Manage Account* window. Here, you can edit the secret.



FortiPAM detects if it manages an account by looking for all the secrets that are currently using the discovery target.

6. In the *Import Account* window:

- a. Enter the password of the AD account.
If you know the password, enter the password in the *Password* field.
Alternatively, click + to automatically generate a random password.
- b. In *Confirm Password*, enter the password again to confirm the password.
Alternatively, click *Copy to clipboard* option and then paste the password.

7. Click *Submit*.

A dialog appears confirming the creation of the secret.

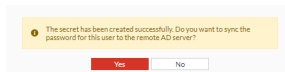

- 8.** Click *Yes* if you want to sync the password of the account to the remote AD server.
The account is imported as a secret and the *Results* tab is updated.

Edit Secret Discovery

Refresh Discover

General Result

Last Discovery Time
The discovery was last performed at 2024-03-28 16:14:10.

Account	Status	Secret	Last Scan Time
<input type="checkbox"/> pam14_idap	Managed	Windows AD_200/pam14_idap	2024/03/13 10:56...
<input type="checkbox"/> robert_fac	Managed	Windows_AD_200/robert_fac	2024/03/13 10:56...
<input type="checkbox"/> pam31_idap	Managed	Windows_AD_200/oa31_idap1111	2024/03/13 10:56...
<input type="checkbox"/> robert_idap3	Managed	Windows_AD_200/robert_idap3	2024/03/13 10:56...
<input type="checkbox"/> robert_idap4	Managed	hhthhkhk	2024/03/13 10:56...
<input type="checkbox"/> robert_idap5	Managed	Windows_AD_200/robert_idap5	2024/03/13 10:56...
<input type="checkbox"/> robert_idap6	Unmanaged		2024/03/13 10:56...

Save Back Discard

Secret settings

Secret Settings allows you to configure secret related settings for FortiPAM.

Go to *Secret Settings* to access the following tabs:

- [Classification tags on page 133](#)
- [Templates on page 134](#)
- [Launchers on page 145](#)
- [Policies on page 156](#)
- [Addresses on page 163](#)
- [Dependency updater on page 166](#)
- [Approval profile on page 171](#)
- [Approval email template on page 175](#)
- [Password changers on page 180](#)
- [Password policies on page 188](#)
- [Character sets on page 191](#)
- [AntiVirus on page 192](#)
- [Data loss prevention \(DLP\) protection for secrets on page 195](#)
- [DLP file pattern on page 202](#)
- [SSH filter profiles on page 204](#)
- [Event filter profile on page 209](#)
- [Integrity check on page 212](#)

Classification tags

Go to *Secret Settings > Classification Tag* to configure classification tags.

A classification tag can be used to classify targets. To add a classification tag to a target, see [Creating a target on page 93](#).

For each classification tag; name, description, and number of references are displayed. Click the number of references to display where the classification tag is used. You can *Edit* or *Delete* these objects if you have permissions to do so.

<input type="checkbox"/>	Name ↕	Description	References ↕
<input type="checkbox"/>	Cloud Platform		0
<input type="checkbox"/>	ESXi		0
<input type="checkbox"/>	Hotmail		0
<input type="checkbox"/>	Linux		3
<input type="checkbox"/>	Other		0

The *Classification Tag* tab contains the following options:

+Create	Select to create a classification tag. See Creating a classification tag on page 134 .
Edit	Select to edit the selected classification tag.
Delete	Select to delete the selected classification tags.
Search	Enter a search term in the search field, then hit <code>Enter</code> to search the jobs list. To narrow down your search, see Column filter .

Creating a classification tag

To create a classification tag:

1. Go to *Secret Settings > Classification Tag*.
2. Select **+Create**.

The *New Classification Tag* window opens.

3. Enter the following information:

Name	Name of the classification tag.
Description	A description for the classification tag.

4. Click **OK**.

Templates

Templates in *Secret Settings* displays a list of customizable and default templates.

The secrets used in FortiPAM are based on templates. The secret templates are customizable so as to meet your requirements.

Secret templates allow configuring the fields a secret requires, as well as the types of launchers that are allowed for the secrets. A password changer can also be configured to automatically change a secret's passwords. See [Password changers on page 180](#).

FortiPAM provides the following default templates:

Cisco User (SSH Secret)	A basic template for a Cisco SSH account.
Machine	A basic template for a general machine, with all default launchers.
Windows Domain Account	A basic template for a Windows Domain account.
Unix Account (SSH Key)	A basic template for a Unix SSH Key account.

ESXi Web	A basic template for an ESXi server using username and password with the web interface.
FortiProduct (SSH Password)	A basic template for a FortiProduct SSH Password account
Unix Account (SSH Password)	A basic template for a Unix SSH Password account.
FortiProduct (SSH Key)	A basic template for a FortiProduct SSH Key account.
Cisco Enable Secret	A basic template for a Cisco enabled secret account.
Unix OpenLDAP Account	A basic template for an Open LDAP account.
AWS Web Account	A basic template for an AWS account.
Target Only	A basic template for a secret that only manages the target host.

When you launch a secret based on the *Target Only* template, you have the following two options:

- You can use the current user's general FortiPAM login credentials to finish the authentication to the target server, i.e., SSO mode. Note that the SSO mode only applies to user logins via the general mode, and MFA credentials (if any) are dismissed.
- Dynamically enter the credentials for the target server during secret launching.



SAML user authentication is not available for secrets based on the *Target Only* template.

Cisco XR Router	A basic template for a Cisco server with XR IOS.
Web Account	A basic template for a Web account.
Windows Machine	A basic template for a Windows machine.
Unix Account (Web CIFS)	A basic template for accessing a Unix system with SMB/CIFS service.
Windows Domain Account (Samba)	A basic template for a Samba Windows Domain account.
HeidiSQL	A basic template for the SQL GUI launcher.
ESXi Server	A basic template for the ESXi server using username and password.
Database Server	A basic template for the SQL server using SQL username and password authentication.



Starting FortiPAM 1.1.0, only the *Launcher* pane of a default secret template can be modified.

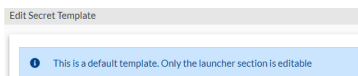

The following default templates have *Server Information* set to *Unix-Like*:

- *Unix OpenLDAP Account*
- *Unix Account (SSH Password)*
- *Unix Account (SSH Key)*
- *Unix Account (Web CIFS)*
- *ESXi Server*

For each template; name, fields, launcher, password changer, server info, and description are displayed.

Name	Fields	Launcher	Password Changer	Server Info	Description
☑ Cisco User (SSH Secret)	Host Username Password	PUTTY Web SSH	Cisco User (SSH Secret)	Cisco	
☑ Machine	Host Username Password	PUTTY Web SSH Remote Desktop-Windows Web RDP		Other	
☑ Windows Domain Account	Domain-Controller Domain Username Password	Remote Desktop-Windows Web RDP Web SMB	Active Directory LDAPS	Other	
☑ Unix Account (SSH Key)	Host Username Public-key Private-key Passphrase	PUTTY WinSCP Web SSH	SSH Key (Unix)	Unix-Like	
☑ ESXi Web	Host Username Password URL	PUTTY WinSCP Web SSH Web Launcher	ESXi Web	Unix-Like	
☑ FortiProduct (SSH Password)	Host Username Password URL	PUTTY Web Launcher Web SSH	SSH Password (FortiProduct)	FortiOS	
☑ Unix Account (SSH Password)	Host Username Password	Remote Desktop-Windows PUTTY WinSCP Web SSH	SSH Password (Unix)	Unix-Like	
☑ FortiProduct (SSH Key)	Host Username Public-key Private-key Passphrase	PUTTY Web SSH	SSH Key (FortiProduct)	FortiOS	
☑ Cisco Enable Secret	Host Password	PUTTY Web SSH	Cisco Enable Secret	Cisco	
☑ Unix OpenLDAP Account	Domain-Controller Domain Username Password	PUTTY Remote Desktop-Windows Web SSH Web RDP	Open LDAPS	Unix-Like	
☑ AWS Web Account	URL Username Password AccountID	Web Launcher		Other	
☑ Target Only	Host URL Domain	PUTTY Web SSH Remote Desktop-Windows Web RDP Web Launcher		Other	
☑ Cisco XR Router	Host Username Password	PUTTY Web SSH	Cisco XR Router	Cisco	
☑ Web Account	URL Username Password	Web Launcher		Other	
☑ Windows Machine	Host Username Password	Remote Desktop-Windows Web RDP	Samba	Other	
☑ Unix Account (Web CIFS)	Host Username Password Domain	Web SMB		Unix-Like	
☑ Windows Domain Account (Samba)	Domain-Controller Domain Username Password	Remote Desktop-Windows Web RDP Web SMB	Samba	Other	
☑ HeidiSQL	Host Username Password SQL Type	HeidiSQL		Other	
☑ ESXi Server	Host Username Password	PUTTY WinSCP Web SSH	ESXi Password	Unix-Like	

The secret templates list contains the following options:

Create	Select to create a new template. See Creating secret templates on page 137 .
Edit	Select to edit the selected template.
Delete	Select to delete the selected templates.
Clone	Select to clone the selected templates.

Search Enter a search term in the search field, then hit **Enter** to search the secret templates list. To narrow down your search, see [Column filter](#).

Creating secret templates

To create a secret template:

1. Go to *Secret Settings > Templates*.
2. In the secret templates list, select *Create*.
The *General* tab in the *New Secret Template* window opens.

The screenshot shows the 'New Secret Template' window with the 'General' tab selected. The form contains the following sections:

- General:** Name (text input), Description (text area), Server Information (radio buttons: Unix-Like, Cisco, FortiOS, Other; 'Unix-Like' is selected).
- Fields:** A table with columns 'Field Name', 'Type', and 'Mandatory'. It currently shows 'No results'.
- Launcher:** A table with columns 'ID', 'Launcher', 'Port', and 'Integrity Check'. It currently shows 'No results'.
- Password Changer:** Password Changer (dropdown), Port (text input: 22), Password Policy (dropdown), Max Number of Verification Retries (text input: 10), Verify After Password Change (radio buttons: Disable, Enable; 'Enable' is selected).
- TOTP Setting:** Length (text input: 6), Duration (text input: 30), Hash Algorithm (dropdown: HMAC-SHA-1).

At the bottom, there are 'Submit' and 'Cancel' buttons.

3. Select *Permission* from the top to switch to the *Permission* tab.

The screenshot shows the 'New Secret Template' window with the 'Permission' tab selected. The 'Access' section has two radio buttons: 'Everyone' (selected) and 'Customized'.

4. Enter the following information:

General	
Name	Name of the template.
Description	Optionally, enter a description.
Server Information	The general type of server to which the template is intended to connect: <ul style="list-style-type: none"> • <i>Unix-Like</i>

- *Cisco*
- *FortiOS*
- *Other*

Fields

Secrets require fields to enter the secret related information.

To add new fields, select *Create* and then enter the following information, and click *OK*:

Field Name	The name of the field.
Type	From the dropdown, select a field type: <ul style="list-style-type: none"> • <i>Passphrase</i>: A passphrase fields. • <i>Password</i>: A password field. • <i>Private-Key</i>: A private-key field. • <i>Public-Key</i>: A public-key field. • <i>Text</i>: A text field. • <i>Username</i>: A username field.
Mandatory	Enable to make this field mandatory or disable if this field will be optional.



From the list, select a field and then select *Edit* to edit the field.
From the list, select fields and then select *Delete* to delete the fields.

Launcher



Launcher helps you access a target server. See [Launchers on page 145](#).

A launcher allows you to log in to a website or device without you needing to know the credentials.

To add a new launcher, select *Create* and then enter the following information, and click *OK*:



You can add up to a maximum of 20 launchers.

Launcher Name	From the dropdown, select a launcher.
	Use the search bar to look up a launcher.
	Use the pen icon to edit a custom launcher.
To create a new launcher, in the dropdown, select <i>Create</i> . Enter the following information and click <i>OK</i> :	

Name	The name of the launcher.
Type	<p>From the dropdown, select a launcher type:</p> <ul style="list-style-type: none"> • <i>Other client</i>: Other client launcher type. • <i>Remote desktop</i>: RDP client launcher type. • <i>SSH client</i>: SSH client launcher type. • <i>VNC</i>: VNC client launcher type.
Executable	<p>The program file name, e.g., <code>putty.exe</code> for an SSH client.</p> <hr/> <p> Ensure that the program path is already added to the environment variable path in Windows before launching the secret.</p> <hr/> <p>Note: An absolute path is also supported, e.g.: <code>C:\Users\user1\Documents\putty.exe</code> <code>C:\Users\user1\Documents\New folder\putty.exe</code></p>
Parameter	<p>The command line parameters:</p> <ul style="list-style-type: none"> • <code>\$DOMAIN</code> • <code>\$TARGET</code> • <code>\$HOST</code> • <code>\$USER</code> • <code>\$PASSWORD</code> • <code>\$VNCPASSWORD</code> • <code>\$PASSPHRASE</code> • <code>\$PUB_KEY</code> • <code>\$PRI_KEY</code> • <code>\$URL</code> • <code>\$PORT</code> • <code>\$TMPFILE</code> <p>- Example For <code>putty.exe</code> as the <i>Executable</i>, <code>-l \$USER -pw \$PASSWORD \$HOST</code> are the parameters.</p>

For `putty.exe` as the *Executable* for SSH execution, `-l $USER -pw $PASSWORD $HOST -m`

`C:\Users\user1\Desktop\cmd.txt`

or

`-l $USER -pw $PASSWORD $HOST -m "C:\Program Files\cmd.txt"` are the parameters.

Note:

When there is no space in the path, double quotes are not necessary:

`-l $USER -pw $PASSWORD $HOST -m C:\Users\user1\Desktop\cmd.txt`

When there is space in the path, double quotes must be used with backslash:

`-l $USER -pw $PASSWORD $HOST -m "C:\Program Files\cmd.txt"`

Initial Commands Configure initializing the environment. See [Creating a new launcher command](#).

Clean Commands Configure cleaning the environment. See [Creating a new launcher command](#).

Launcher Port

The launcher port number.



The port number will be mapped to the launcher variable ``$PORT``.



The minimum allowed value is 1.

Integrity Check

Enable/disable integrity check. For information on integrity check, see [Integrity check on page 212](#).



The *Integrity Check* option can only be edited if you choose a launcher in the *Launcher Name* option with a client software entry enabled and selected.

Note: The option is disabled by default.



From the list, select a launcher and then select *Edit* to edit the launcher. From the list, select launchers and then select *Delete* to delete the launchers.

Password Changer

A password changer can be configured for a custom secret template to change the password of a secret periodically and to check the health of a secret periodically.

Note: The option is enabled by default.

Password Changer

From the dropdown, select the password changer that will be used for this template or create a new password changer. See [Creating a password changer on page 181](#).



Use the search for to look up a password changer.



Use the pen icon next to a password changer to edit it.

Port

The port used for the password changer (default = 22).

Password Policy

The password policy to use in the password changer.

From the dropdown, select a password policy or create a new password policy. See [Creating a password policy on page 189](#).



Use the search for to look up a password policy.



Use the pen icon next to a password policy to edit it.

Max Number of Verification Retries

The maximum number of retries allowed after which the connection fails (default = 10).

Verify After Password Change

When enabled, whenever secrets with the template conducts a password change, a verification of the newly changed password is ran.

Note: The option is enabled by default.

TOTP Setting

TOTP (Time-based one-time password) settings.

The TOTP configuration from a secret template can be inherited by all the secrets using this template.

When configuring the secret, you can override the secret template TOTP configuration. See [TOTP Setting in Creating a secret on page 60](#).



See [Limitations of TOTP on FortiPAM on page 145](#).

Length

The length of the TOTP (default = 6, 4 - 9).

Duration

The duration for which the TOTP is valid, in seconds (default = 30, 30 - 90).

Hash Algorithm	Select from the following hash algorithms for TOTP: <ul style="list-style-type: none"> • <i>HMAC-SHA-1</i> (default) • <i>HMAC-SHA-256</i> • <i>HMAC-SHA-512</i>
Permission	
Template access control settings.	
Access	Template accessible to: <ul style="list-style-type: none"> • <i>Everyone</i>: All users have <i>Read/Write</i> permission for templates (default). • <i>Customized</i>: A user permission and a group permission table must be configured.
User Permission	The level of user access to the template. See User Permission on page 142 .
 <p>The option is only available when <i>Access</i> is set to <i>Customized</i>.</p>	
<p>For column settings, see Tables on page 25.</p>	
Group Permission	The level of user group access to the template. See Group Permission on page 143 .
 <p>The option is only available when <i>Access</i> is set to <i>Customized</i>.</p>	
<p>For column settings, see Tables on page 25.</p>	

5. Click *Submit*.

User Permission

1. In Step 3, when [Creating secret templates on page 137](#), select *Create* in *User Permission*. The *New User Permission* window opens.

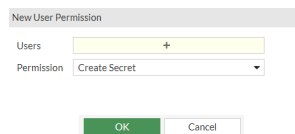

2. Enter the following information:

Users Select + and from the list, select users in the *Select Entries* window.

To add a new user:

- From the *Select Entries* window, select *Create* and then select *+User List*. The *New User List* wizard opens.
- Follow the steps in [Creating a user on page 218](#), starting step 2 to create a new user.



Use the search bar to look up a user.



Use the pen icon next to a user to edit it.

Permission From the dropdown, select an option:

- Create Secret*: Ability to see and use the template to create secrets.
- Owner*: The highest possible permission level with the ability to create, edit, and delete templates.



Every template must have at least one owner.

3. Click *OK*.



From the list, select a user permission entry and then select *Edit* to edit it.
From the list, select user permission entries and then select *Delete* to delete them.

Group Permission

1. In Step 3, when [Creating secret templates on page 137](#), select *Create* in *Group Permission*. The *New Group Permission* window opens.

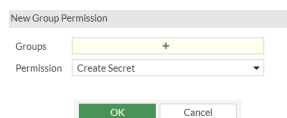

2. Enter the following information:

Groups

Select + and from the list, select user groups in the *Select Entries* window.

To add a new user group:

1. From the *Select Entries* window, select *Create*.
The *Create New User Group* window opens.
2. Follow the steps in [Creating user groups](#), starting step 3.



Use the search bar to look up a user group.



Use the pen icon next to a user group to edit it.

Permission

From the dropdown, select an option:

- *Create Secret*: Ability to see and use the template to create secrets.
- *Owner*: The highest possible permission level with the ability to create, edit, and delete templates.



Every template must have at least one owner.

3. Click *OK*.

From the list, select a user group permission entry and then select *Edit* to edit it.
From the list, select user group permission entries and then select *Delete* to delete them.

Configuring TOTP settings via the secret template CLI commands - Example**To configure TOTP settings via the CLI:**

1. In the CLI console, enter the following commands:

```
config secret template
edit Unix\ Account\ (SSH\ Password)
config totp-setting
set totp-length 8
set totp-duration 30
set hash-type hmac-sha1
end
end
```

Limitations of TOTP on FortiPAM

1. TOTP auto delivery only supports SSH target authentication.
2. Password changer does not support public key + TOTP authentication.
3. With TOTP, WebSSH only supports the keyboard-interactive authentication method.
4. With a non-proxy or Web launcher, the TOTP code must be copied and entered manually.
5. Do not enable the password changer for an SSH server with password + FortiToken authentication if the username, password, and FortiToken are from another LDAP server.

Launchers

Secret launchers allow users to remotely gain access to a target without the need to know, view, or copy the passwords stored in FortiPAM.



A secret launcher stores an executable and the parameters needed to start a connection to a target.



In proxy mode, browsing triggers ZTNA tunnel between the FortiClient and FortiPAM server. The FortiPAM chrome extension may have compatibility issues for some specific login pages and cannot fill in the user name and password.



To avoid DoS attacks, multiple secret launching from the same user within 1 second is blocked.

For each secret launcher; name, type, file launcher, client software, executable, parameter, and references are displayed.

Name	Type	File Launcher	Client Software	Executable	Parameter	References
HeidiSQL	Other client	False	Disabled			1
Microsoft SQL CLI	Other client	False	Disabled			1
Microsoft SQL CLI - DB_name	Other client	False	Disabled	sqlcmd.exe	-\$HOST -U \$USER -P \$PASSWORD -d fpam_test_db -y 30 -Y 30	1
Microsoft SQL CLI - fqdn	Other client	False	Disabled	sqlcmd.exe	-\$fpam-sql-svr.database.windows.net -U \$USER -P \$PASSWORD -y 30 -Y 30	1
MobaXterm	SSH client	False	Disabled			0
MySQL CLI	Other client	False	Disabled			1
MySQL Shell	Other client	False	Disabled			1
PostgreSQL CLI	Other client	False	Disabled			1
PuTTY	SSH client	False	Disabled			15
Remote Desktop-Windows	Remote desktop	False	Disabled			10
SSH CLI	SSH client	False	Disabled			0
SSMS	Other client	False	Disabled			1
SecureCRT	SSH client	False	Disabled			0
TightVNC	VNC	False	Disabled			2
VNC Viewer	VNC	False	Disabled			2
Web Launcher	FortiClient Web extension	False	Disabled			5
Web RDP	RDP over Web	False	Disabled			10
Web SFTP	SFTP over Web	True	Disabled			2
Web SMB	SMB over Web	True	Disabled			6
Web SSH	SSH over Web	False	Disabled			14
Web Telnet	Telnet over Web	False	Disabled			0
Web VNC	VNC over Web	False	Disabled			2
WinSCP	SSH client	True	Disabled			5
Xshell	SSH client	False	Disabled			0

The following default launchers are available in FortiPAM:

- *HeidiSQL*: An SQL GUI launcher that supports `mssql`, `psql`, and `mysql`.
- *Microsoft SQL CLI*: A MSSQL CLI launcher for `sqlcmd.exe`.
- *MobaXterm*: An SSH client using MobaXterm.
- *MySQL CLI*: A MYSQL CLI launcher for `mysql.exe`.
- *MySQL Shell*: A MYSQL CLI launcher for `mysqlsh.exe`.
- *PostgreSQL CLI*: A PostgreSQL CLI launcher for `psql.exe`.



To use `psql.exe`:

- You must add the application path to the `PATH` environment variable in the system, e.g., `C:\Program Files\PostgreSQL\\bin`.
- Restart FortiClient.

PostgreSQL CLI default launcher is connected to postgres by default.



To switch the database:

1. use `\l` to see the full list of all the available database.
2. Use `\c <dbname>` to change to the desired database.

- *PuTTY*: A basic SSH client using PuTTY.
- *Remote Desktop- Windows*: A basic RDP client using remote desktop.
- *SSH CLI*: An SSH CLI launcher for `ssh.exe`.
- *SSMS*: An MSSQL GUI launcher.



You must open SSMS locally at least once (it does not require connecting to the database) to set up the initial software cache; otherwise, the SSMS launcher fails.

- *SecureCRT*: An SSH client using SecureCRT.
 - *TightVNC*: A basic VNC client using TightVNC.
-



The TightVNC client does not support connecting to a macOS server in non-proxy mode.

- *VNC Viewer*: A basic VNC client using VNC Viewer.
 - *Web Launcher*: A basic web launcher using Fortinet's FortiClient web extension.
-



For secrets created for a target with *Web Proxy* enabled:

- *Web Launcher* is available to users with *View*, *Edit*, or *Owner* permission for the secret.

For secrets not created for a target or for secrets created for a target with *Web Proxy* disabled:

- *Web Launcher* is unavailable to users with *View* permission for the secret, as the password can be retrieved using browser dev tools.
- *Web Launcher* is only available to users with *Edit* or *Owner* permission for the secret.

For information on setting up folder and secret permissions, see [Creating a folder on page 110](#) and [Creating a secret on page 60](#).

- *Web RDP*: A basic browser based RDP launcher.

To copy and paste when accessing a target using the *Web RDP* launcher:

1. Press F8.

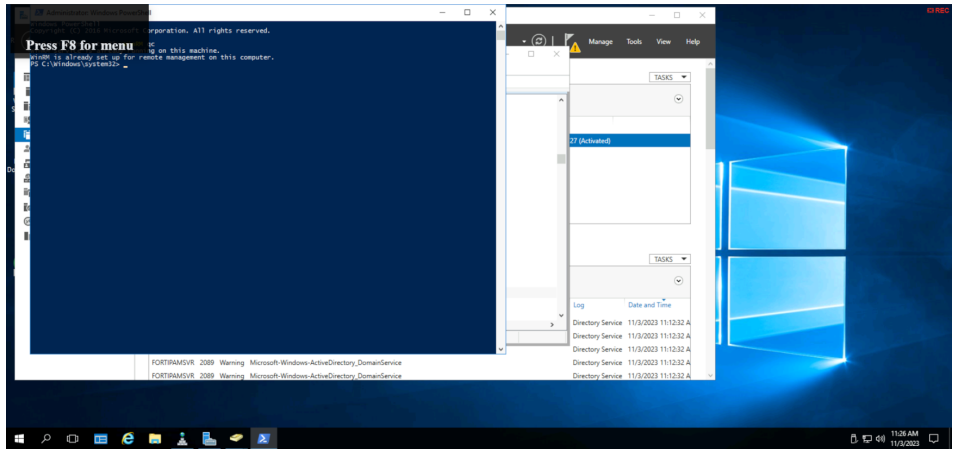

A new menu opens.

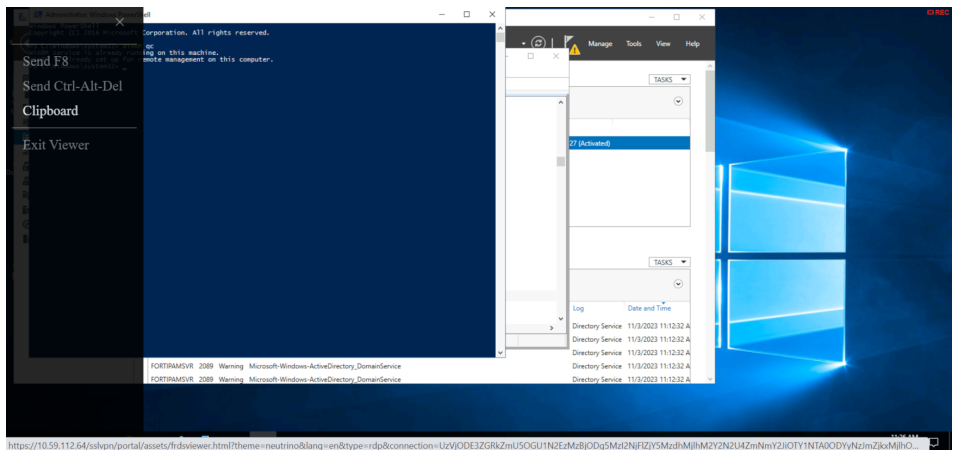

2. From the menu, select *Clipboard*.
The RDP Clipboard menu opens.

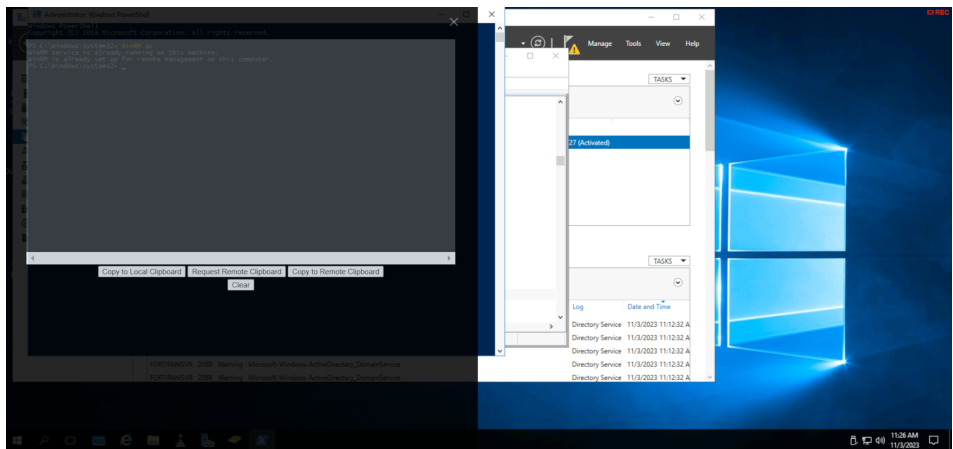

Copy from Local to Remote:

- a. Enter/paste (`Ctrl + v`) the selected text from the local machine to the text box similar to the one in step 2.
- b. In the RDP Clipboard menu, select *Copy to Remote Clipboard*.
- c. From the top-right, click *X* to close the text box.
- d. On the remote machine, use `Ctrl + v` to paste.

Copy from Remote to Local:

- a. On the remote machine, copy the text (`Ctrl + c`).
- b. In the RDP Clipboard menu (the one in step 2), select *Request Remote Clipboard*.
The copied text appears in the text box.
- c. In the RDP Clipboard menu, select *Copy to Local Clipboard*.
The text is now available on the local clipboard.
- d. From the top-right, click *X* to close the text box.
- e. On the local machine, use `Ctrl + v` to paste.

-
- *Web SFTP*: A basic browser based SFTP web launcher.
 - *Web SMB*: A basic browser based SMB web launcher.
 - *Web SSH*: A basic browser based SSH web launcher.
-



To copy and paste in the Web SSH console, select the text and then use `Ctrl+ Shift + v`.

- *Web Telnet*: A basic browser based Telnet web launcher.
 - *Web VNC*: A basic browser based VNC web launcher.
 - *WinSCP*: A basic WinSCP client using SSH.
 - *Xshell*: An SSH client using Xshell.
 - *FortiClient Web extension FortiClient Web Launcher*
 - *RDP over Web RDP over Web Launcher*
 - *SSH over Web SSH over Web Launcher*
 - *VNC over Web VNC over Web Launcher*
 - *SMB over Web SMB over Web Launcher*
 - *SFTP over Web SFTP over Web Launcher*
-



The following launchers should not be used for customized launcher:

- *FortiClient Web extension FortiClient Web Launcher*
- *RDP over Web RDP over Web Launcher*
- *SSH over Web SSH over Web Launcher*
- *VNC over Web VNC over Web Launcher*
- *SMB over Web SMB over Web Launcher*
- *SFTP over Web SFTP over Web Launcher*

These launchers will be removed in a future FortiPAM version.



Chrome, Edge, and Firefox are the supported browsers.



Starting FortiPAM 1.1.0, only the *Client Software* toggle/dropdown of a default secret launcher can be modified.

Only client software is editable in default launcher.



Web SSH, Web RDP, Web VNC, Web SFTP, and Web SMB default launchers always work in proxy mode irrespective of the *Proxy Mode* setting.



PuTTY and WinSCP launchers are not supported when the secret is in non-proxy mode, and the secret uses an SSH key for authentication.

TightVNC launcher is not supported when the secret is in non-proxy mode and requires a username for authentication.

In proxy mode, the following launchers are available to all users:

- Web SSH
- Web RDP
- Web VNC
- Web SFTP
- Web SMB
- Web Launcher
- PuTTY
- WinSCP
- RDP
- VNC Viewer
- TightVNC

In non-proxy mode, the following launchers are available to all users:

- Web SSH (always in proxy mode)
- Web RDP (always in proxy mode)
- Web VNC (always in proxy mode)
- Web SFTP (always in proxy mode)
- Web SMB (always in proxy mode)

In non-proxy mode, the following launchers are only available to users with the permission to view secret password:

- PuTTY
- WinSCP
- RDP
- VNC Viewer
- TightVNC

The *Launchers* tab contains the following options:

Create	Select to create a new launcher. Creating a launcher on page 151.
Edit	Select to edit the selected launcher.
Delete	Select to delete the selected launchers.
Clone	Select to clone the selected launcher.
Search	Enter a search term in the search field, then hit <code>Enter</code> to search the launchers list. To narrow down your search, see Column filter.

Preconfiguration for MobaXterm, Xshell, and SecureCRT

Before you use FortiPAM to launch secrets in MobaXterm, Xshell, or SecureCRT, ensure that these applications are correctly installed and configured on your local endpoint (user machine).

Execute each application independently to confirm that it operates correctly. Pay close attention to any initial setup or configuration prompts that may appear during the first launch. It is essential to have all the necessary configurations in place for the applications to run smoothly.

This preconfiguration step is essential to avoid issues or disruptions when using these secrets within FortiPAM. If you encounter problems during the initial manual launch, please resolve them before integrating FortiPAM with these applications.





Once you have verified that these applications work correctly on your endpoint, you can seamlessly integrate them with FortiPAM for enhanced access control and security.

Creating a launcher

To create a launcher:

1. Go to *Secret Settings > Launchers*.
2. In the secret launchers list, select *Create* to create a new secret launcher.
3. The *New Secret Launcher* window opens.

4. Enter the following information:

Name	The name of the launcher.
Type	<p>From the dropdown, select a type:</p> <ul style="list-style-type: none"> • <i>Other client</i>: Other client launcher type. • <i>Remote desktop</i>: RDP client launcher type. • <i>SSH client</i>: SSH client launcher type. • <i>VNC</i>: VNC client launcher type.
Executable	<p>The program file name, e.g., <code>putty.exe</code> for an SSH client.</p> <hr/> <p> Ensure that the program path is already added to the environment variable path in Windows before launching the secret.</p> <hr/> <p> An absolute path is also supported, e.g.:</p> <p><code>C:\Users\user1\Documents\putty.exe</code> <code>C:\Users\user1\Documents\New folder\putty.exe</code></p> <hr/> <p> Some applications may require you to add its path to the PATH environment variable in the system.</p> <hr/>
Parameter	<p>The command line parameters from the <i>Available Variables</i> list.</p> <p>Valid field variables are:</p> <ul style="list-style-type: none"> • \$DOMAIN • \$HOST • \$USER • \$PASSWORD • \$VNCPASSWORD <hr/> <p> \$VNCPASSWORD is filled with the obfuscated password sometimes used by VNC when saving the password to a file.</p> <hr/> <ul style="list-style-type: none"> • \$PASSPHRASE <hr/> <p> \$PASSPHRASE refers to the passphrase of SSH keys.</p> <hr/> <ul style="list-style-type: none"> • \$PUB_KEY • \$PRI_KEY • \$URL

- \$PORT



\$PORT is filled in using the port value assigned to the launcher in the template.

- \$TMPFILE



\$TMPFILE is filled in with the path to a temporary file, generally for use with launchers that require loading config files (when launching with non-proxy mode).

User input variables are:

- \$TARGET



The \$TARGET user input variable can replace the \$HOST field variable. This allows you to specify the 'target' at the launch time rather than having it hard coded in secret itself.

- Example

For `putty.exe` as the *Executable*, `-l $USER -pw $PASSWORD $HOST` are the parameters.

For `putty.exe` as the *Executable* for SSH execution, `-l $USER -pw $PASSWORD $HOST -m C:\Users\user1\Desktop\cmd.txt`

or

`-l $USER -pw $PASSWORD $HOST -m "C:\Program Files\cmd.txt"` are the parameters.

Note:

When there is no space in the path, double quotes are not necessary:

```
-l $USER -pw $PASSWORD $HOST -m
C:\Users\user1\Desktop\cmd.txt
```

When there is space in the path, double quotes must be used with backslash:

```
-l $USER -pw $PASSWORD $HOST -m "C:\Program
Files\cmd.txt"
```

Client Software

Enable to select a client software entry from the dropdown. See [Integrity check on page 212](#).



Use the search bar to look up a client software entry.

Note: The option is disabled by default.

Initial Commands

Configure initializing the environment. See [Creating a new launcher command on page 154](#).

Clean Commands

Configure cleaning the environment. See [Creating a new launcher command on page 154](#).

5. Click *Submit*.

Non-proxy environment

When using launchers with non-proxy mode, launchers may require the environment to be initialized beforehand. You may specify this with init-commands and clean-commands.

Note: Init-commands and clean-commands only run in the non-proxy mode.

Creating a new launcher command

To create a new launcher command:

1. In step 3 when [Creating a secret launcher](#), select *Create* in the *Initial Commands* or *Clean Commands* pane. The *New Launcher Command* window opens.

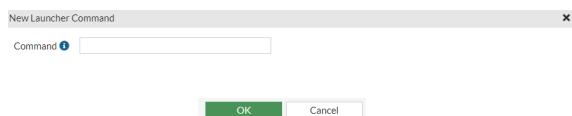

2. In *Command*, enter the command.



Enter `$` to get the list of valid variables.

3. Click *OK*.



- Select the command from the list and then select *Edit* to edit it.
- Select command(s) from the list and then select *Delete* to delete them.



You can create launchers to be used as file launchers for SSH clients, SMB over the Web, SFTP over the Web, and other types of launchers.

Creating launchers via the CLI - Example

1. In the CLI console, enter the following commands:

```
config secret launcher
edit "Example Windows RDP"
set exe "mstsc.exe"
set para "/V:$TARGET:$PORT /noConsentPrompt"
set type rdp
config init-commands
edit 1
set cmd "cmdkey /generic:$TARGET /user:$USER /pass:$PASSWORD"
next
```

```

end
config clean-commands
  edit 1
    set cmd "cmdkey /del:$TARGET"
  next
end
next
end

```

Example secret configurations with launchers - example

To configure a secret with Web SSH launcher:

1. Go to *Secrets > Secret List*.
2. In *Secret List*, select *Create*.
The *Create New Secret in:* dialog appears.
3. Select the folder where you intend to add the secret.
4. Select *Create Secret*.
The *New Secret* window opens.
5. Enter a name for the secret.
6. In the *Template* dropdown, select from the following templates if the templates meet your requirements else see [Creating secret templates on page 137](#) to create a new template:
Note: Ensure that the template uses *Web SSH* as its launcher.
 - a. *Unix Account (SSH Password)*
 - b. *Unix Account (SSH Key)*
 - c. *FortiProduct (SSH Password)*



Unix Account (SSH Password), *Unix Account (SSH Key)*, and *FortiProduct(SSH Password)* secret templates are preconfigured with *Web SSH* launcher.

7. In *Fields*, enter the required information.
8. Click *Submit*.
9. In the secret list, select the newly created secret, and select *Launch Secret*.
10. In *Launch Progress*, select *Web SSH*, and then select *Launch*.

To configure a secret with Web RDP launcher:

1. Repeat steps 1 to 5 from [Configuring a secret with Web SSH launcher](#) to create a new secret.
2. In the *Template* dropdown, select from the following templates if the templates meet your requirements else see [Creating secret templates on page 137](#) to create a new template:
 - a. *Windows Domain Account*
 - b. *Windows Domain Account(Samba)***Note:** Ensure that the template uses *Web RDP* as its launcher.



Windows Domain Account and *Windows Domain Account(Samba)* secret templates are preconfigured with *Web RDP* launcher.

3. Repeat steps 7 to 9 from [Configuring a secret with Web SSH launcher](#).
4. In *Launch Progress*, select *Web RDP*, and then select *Launch*.

To configure a secret with Web VNC launcher:

1. Repeat steps 1 to 5 from [Configuring a secret with Web SSH launcher](#) to create a new secret.
2. In the *Template* dropdown, select the *Machine* template if the template meet your requirements else see [Creating secret templates on page 137](#) to create a new template.

Note: Ensure that the template uses *Web VNC* as its launcher.



The *Machine* secret template is preconfigured with *Web VNC* launcher.

Alternatively, in the CLI console, enter the following commands to create a new template with *Web VNC* launcher:

```
config secret template
  edit <name> #name of the template
    config field
      edit <name> #name of the field
        set type username
        set mandatory enable #the field is mandatory
      next
      edit <name>
        set type password
        set mandatory enable
      next
    end
  config launcher
    edit <id>
      set launcher-name "Web VNC" #Web VNC set as the secret launcher
      set port 5900 #default value
    next
  end
```

From the *Template* dropdown, select the template you created using the CLI.

3. Repeat steps 7 to 9 from [Configuring a secret with Web SSH launcher](#). Ensure that *Automatic Password Changing* is disabled.
4. In *Launch Progress*, select *Web VNC*, and then select *Launch*.

Policies

A secret policy aims to establish guidelines for handling and to protect sensitive information, such as passwords, secret attributes, and personal data. The secret policy helps organizations maintain the confidentiality, integrity, and availability of sensitive information and to minimize the risk of data breaches.

Policies in *Secret Settings* displays a list of secret policies.

Secret policies controls the settings related to a secret. A policy is assigned to a folder when the folder is created. Secrets in a folder follow the rules set in the policy associated with the folder.

A policy allows you to set the following attributes by default for a secret:

- Automatic Password Changing
- Automatic Password Verification
- Enable Session Recording
- Enable Proxy
- Tunnel Encryption
- Requires Checkout
- Requires Approval to Launch Secret
- Requires Approval to Launch Job
- Block RDP Clipboard
- SSH Filter
- Antivirus Scan
- RDP Security Level

The *Policies* tab looks like the following:

Name	Password Changer	Password Verification	Recording	Proxy Enabled	Tunnel Encryption	Block Rdp Clipboard	Checkout Enabled	Needs approval	SSH Filter	Antivirus Sc
default	Not Set	Not Set	Not Set	Enable	Disable	Not Set	Not Set	Not Set	Not Set	Not Set
default_clone	Not Set	Not Set	Not Set	Enable	Disable	Not Set	Not Set	Not Set	Not Set	Not Set

The *Policies* list contains the following options:

Create	Select to create a policy. See Creating a policy on page 157 .
Edit	Select to edit the selected policy.
Clone	Select to clone the selected policy.
Delete	Select to delete the selected policies.
 <p>The default secret policy cannot be deleted.</p>	
Search	Enter a search term in the search field, then hit <code>Enter</code> to search the policies list. To narrow down your search, see Column filter .

Creating a policy



To create a policy:

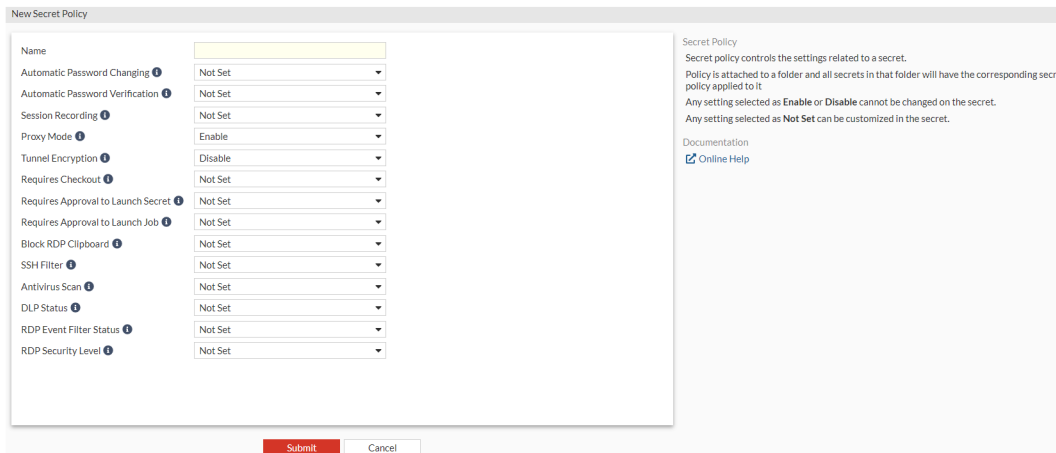

1. Go to *Secret Settings > Policies*.
2. In *Policies*, select *Create*.
The *New Secret Policy* window opens.



3. Enter the following information:

Name	Name of the policy.
Automatic Password Changing	Select <i>Enable</i> , <i>Disable</i> , or <i>Not Set</i> . When enabled, password changer for secrets is activated to periodically change the password.
Recursive	Displays the password changing schedule based on your selections for the related settings.
Start Time	The date and time when the <i>Change Interval (min)</i> begins. Enter date (MM/DD/YYYY) and time or select the <i>Calendar</i> icon and then select a date and time.
Recurrence	From the dropdown, select from the following three frequencies of recurrence: <ul style="list-style-type: none"> • <i>Daily</i> • <i>Weekly</i> • <i>Monthly</i>
Repeat every	The number of days/weeks/months after which the password is changed (1-400).
Occurs on	Select from the following days of the month when the password is automatically changed: <ul style="list-style-type: none"> • <i>First</i> • <i>Second</i> • <i>Third</i> • <i>Last</i> • <i>Last Day</i> • <i>Day</i> Select days of the week when the password is automatically changed. When you select <i>Day</i> , select + to add days of the month when the password is automatically changed. Note: The option is only available when <i>Recurrence</i> is set as <i>Weekly</i> or <i>Monthly</i> .

Editable in Secret	Enable/disable users from customizing the password change schedule in the secret.
Automatic Password Verification	Select <i>Enable</i> , <i>Disable</i> , or <i>Not Set</i> . When enabled, password changer for secrets is activated to periodically verify the password.
Verification Interval (min)	The time interval at which the secrets are tested for accuracy, in minutes (default = 60, 5 - 44640).
Start Time	The date and time when the <i>Interval(min)</i> begins. Enter date (MM/DD/YYYY) and time or select the <i>Calendar</i> icon and then select a date and time.
Editable in Secret	When enabled, you can customize the password verification schedule in the secret.
Session Recording	Select <i>Enable</i> , <i>Disable</i> , or <i>Not Set</i> . When enabled, user action performed on the secret is recorded.
	 <p>The video file is available in the log for users with appropriate permission.</p>
Proxy Mode	Select <i>Enable</i> , <i>Disable</i> , or <i>Not Set</i> . When enabled, FortiPAM is responsible to proxy the connection from the user to the secret. When disabled, the non-proxy (direct) mode is used. See Modes of operation on page 29 .
Tunnel Encryption	Select <i>Enable</i> , <i>Disable</i> , or <i>Not Set</i> . When launching a native launcher, FortiClient creates a tunnel between the endpoint and FortiPAM. The protocol stack is HTTP/TLS/TCP. The HTTP request gives information on the target server then FortiPAM connects to the target server. After that, two protocol options exist for the tunnel between FortiClient and FortiPAM. One is to clear the TLS layer for better throughput and performance. The other is to keep the TLS layer. The launcher's protocol traffic is inside the TLS secure tunnel. If the launcher's protocol is not secure, like VNC, it is strongly recommended to enable this option so that the traffic is in a secure tunnel.
	 <p>When there is an HTTPS Man In The Middle device, e.g., FortiGate or FortiWeb between FortiClient and FortiPAM, you must enable the <i>Tunnel Encryption</i> option. Otherwise, the connection will be disconnected, and the launching will fail.</p>
	When set to <i>Not Set</i> , secrets using the policy can have the option set as either <i>Enable</i> or <i>Disable</i> .

	When the option is enabled or disabled, all the secrets using this policy have the same setting for this option as set in the policy.
Requires Checkout	<p>Select <i>Enable</i>, <i>Disable</i>, or <i>Not Set</i>.</p> <p>When enabled, users are forced to check out the secret before gaining access.</p> <hr/> <div style="display: flex; align-items: center;">  <p>At a given time, only one user can check out a secret. Other approved users must wait for the secret to be checked in or wait for the checkout duration to lapse before accessing the secret.</p> </div> <hr/> <p>See Check out and check in a secret on page 83.</p>
Checkout duration	The checkout duration, in minutes (default = 30, 3 - 120).
Checkin Password Change	Enable/disable automatically changing the password when the user checks in.
Renew Checkout	Enable/disable renewing checkouts.
Max Renew Count	When <i>Renew Checkout</i> is enabled, enter the maximum number of renewals allowed for the user with exclusive access to the secret (default = 1, 1 - 5).
Requires Approval to Launch Secret	<p>Select <i>Enable</i>, <i>Disable</i>, or <i>Not Set</i>.</p> <p>When enabled, users are forced to request permission from the approvers defined in the approval profile before gaining access.</p> <p>See Make a request on page 117 and Approval flow on page 170.</p>
Requires Approval to Launch Job	<p>When enabled, users are forced to request permission from the approvers defined in approval profile before being able to perform a job on a secret.</p> <p>See Make a request on page 117 and Approval flow on page 170.</p>
Approval Profile	<p>From the dropdown, select an approval profile, or select <i>Create</i> to create a new approval profile. See Approval profile on page 171.</p> <hr/> <div style="display: flex; align-items: center;">  <p>Use the search bar to look up an approval profile.</p> </div> <hr/> <div style="display: flex; align-items: center;">  <p>Use the pen icon next to the approval profile to edit it.</p> </div> <hr/>
Block RDP Clipboard	<p>Select <i>Enable</i>, <i>Disable</i>, or <i>Not Set</i>.</p> <p>When enabled, user is unable to copy/paste from the secret launcher.</p>
SSH Filter	<p>Select <i>Enable</i>, <i>Disable</i>, or <i>Not Set</i>.</p> <p>When enabled, commands defined in the SSH profile to be executed on the secret are blocked.</p>
SSH Filter Profile	From the dropdown, select an SSH filter profile.

Bypass For Owner	<p>Enable/disable allowing secret owners to bypass the SSH command filter (default = disable).</p> <p>Once enabled, secret owners can send otherwise prohibited commands (listed in the SSH filter profile) to the targets.</p> <p>Note: The option is only available when <i>SSH Filter</i> is enabled.</p>
Antivirus Scan	<p>Select <i>Enable</i>, <i>Disable</i>, or <i>Not Set</i>.</p> <p>When enabled, it enforces an antivirus profile on the secret. See AntiVirus on page 192.</p>
Antivirus Profile	From the dropdown, select an antivirus profile.
DLP Status	<p>Select <i>Enable</i>, <i>Disable</i>, or <i>Not Set</i>.</p> <p>When enabled, it enforces a particular DLP profile on the secret.</p>
DLP Filter Profile	From the dropdown, select a DLP filter profile.
RDP Event Filter Status	<p>Select <i>Enable</i>, <i>Disable</i>, or <i>Not Set</i>.</p> <p>When enabled, it enforces a particular event filter profile on the secret.</p>
RDP Event Filter Profile	From the dropdown, select an RDP filter profile.
RDP Security Level	<p>Select a security level when establishing a RDP connection to the secret:</p> <ul style="list-style-type: none"> • <i>Best Effort</i>: If the server supports NLA, FortiPAM uses NLA to authenticate. Otherwise, FortiPAM conducts standard RDP authentication with the server through RDP over TLS. • <i>NLA</i>: Network Level Authentication (CredSSP). When an RDP launcher is launched, FortiPAM is forced to use CredSSP (NLA) to authenticate with the target server. • <i>Not Set</i> • <i>RDP</i>: FortiPAM uses the standard RDP encryption provided by the RDP protocol without using TLS (Web-RDP only). • <i>TLS</i>: RDP over TLS. FortiPAM uses secured connection with encryption protocol TLS to connect with the target server.
RDP Auto TOTP	<p>Enable/disable RDP auto Time-based One-time Password (TOTP).</p> <p>Note: The option is only available when <i>RDP Security Level</i> is set as <i>TLS</i>.</p>
RDP Restricted Admin Mode	<p>Enable/disable RDP restricted admin mode.</p> <p>Restricted admin mode prevents the transmission of reusable credentials to the remote system to which you connect using remote desktop. This prevents your credentials from being harvested during the initial connection process if the remote server has been compromised.</p> <p>Note: The option is only available when <i>RDP Security Level</i> is set as <i>Best Effort</i> or <i>NLA</i>.</p>



Settings set as *Enable* or *Disable* cannot be changed on the secret.

Settings set as *Not Set* can be customized in the secret.

For example - example:

While setting up a policy:

- If *Automatic Password Changing* is enabled, then the secrets in the folder where the policy applies has *Automatic Password Changing* enabled as well.
- If *Automatic Password Changing* is not set, then the secrets in the folder where the policy applies can have *Automatic Password Changing* set as either *Enable* or *Disable*.

4. Click *Submit*.

See [Applying a policy to a folder on page 162](#).

Configuring a secret policy where the secret owner can bypass the SSH command filter - example

To configure the secret policy:

1. In the CLI console, enter the following commands:

```
config secret policy
edit "default"
set ssh-filter enable
set block-rdp-clipboard disable
set bypass-ssh-filter-for-owner enable #enable allowing secret owners to bypass the
SSH command filter
next
end
```

Applying a policy to a folder

To apply a policy to a folder:

1. Go to a folder in *Secrets > Personal Folder/Public Folder*.
2. Either select *Edit Current Folder* to edit the folder and skip to step 5, or from the *Create* dropdown, select *Folder*.
3. Enter the name of the folder.
4. From the *Parent Folder* dropdown, select a folder.
5. Enable *Inherit Policy*, so that the folder follows the parent folder policy.



You cannot inherit policy for a root folder.

If *Inherit Policy* is disabled, from the *Secret Policy* dropdown, select a policy profile.

Select *Create* to create a new secret policy. See [Creating a policy on page 157](#).



Use the search bar to look up a policy.



Use the pen icon next to a policy to edit it.

6. Click *Save/Submit*.

Addresses

The *Addresses* tab in *Secret Settings* displays a list of configured addresses.

An address is a set of one or more IP addresses, represented as a domain name, an IP address and a subnet mask, or an IP address range. You can also specify an address as a country. The address can apply to all interfaces, or you can configure a specific interface.

You can create an address groups, which defines a group of related addresses.

For an address; name, details, interface, type, and references are shown.

Name	Details	Interface	Type	Ref.
IP Range/Subnet				
FABRIC_DEVICE	0.0.0.0/0		Address	0
FIREWALL_AUTH_PORTAL_ADDRESS	0.0.0.0/0		Address	0
SSLVPN_TUNNEL_ADDR1	10.212.134.200 - 10.212.134.210		Address	2
all	0.0.0.0/0		Address	8
none	0.0.0.0/32		Address	0
FQDN				
gmail.com	gmail.com		Address	1
login.microsoft.com	login.microsoft.com		Address	1
login.microsoftonline.com	login.microsoftonline.com		Address	1
login.windows.net	login.windows.net		Address	1
wildcard.dropbox.com	*dropbox.com		Address	0
wildcard.google.com	*google.com		Address	1
Address Group				
G Suite	gmail.com wildcard.google.com		Address Group	0
Microsoft Office 365	login.microsoftonline.com login.microsoft.com login.windows.net		Address Group	0
IPv6 Range/Subnet				
SSLVPN_TUNNEL_IPv6_ADDR1	ffff::/120		IPv6 Address	2
all	::/0		IPv6 Address	0
none	::/128		IPv6 Address	0
URL Pattern				
saml_auth_addr	all		Proxy Address	0
token_query	all		Proxy Address	1
HTTP Header				
token_hdr	all		Proxy Address	1

The *Addresses* tab contains the following options:

+Create New From the dropdown, select *Address* or *Address Group* to create an address or an address group.
See [Creating an address on page 164](#) and [Creating an address group on page 165](#)

Edit	Select to edit the selected address or address group.
Clone	Select to clone the selected address or address group.
Delete	Select to delete the selected addresses or address groups.
Search	Enter a search term in the search field, then hit Enter to search the list. To narrow down your search, see Column filter .
Refresh	To refresh the contents, click the refresh icon on the bottom-right.

Creating an address

To create an address:

1. Go to *Secret Settings > Addresses*.
2. From the **+Create New** dropdown, select *Address*.
The *New Address* window opens.

3. Enter the following information:

Name	Name of the address.
Type	From the dropdown, select from the following options when the <i>Category</i> is <i>Address</i> : <ul style="list-style-type: none"> • <i>Subnet</i> (default) • <i>IP Range</i> • <i>FQDN</i>
IP/Netmask	Enter the IP address and the netmask. Note: The option is only available when the <i>Type</i> is <i>Subnet</i> .
IP Range	Enter the IP address range. Note: The option is only available when the <i>Type</i> is <i>IP Range</i> .
FQDN	Enter the Fully Qualified Domain Name (FQDN). Note: The option is only available when the <i>Type</i> is <i>FQDN</i> .
Comments	Optionally, enter comments about the address.

4. Click **OK**.

Creating an address using the CLI - example

1. Enter the following commands in the CLI console:

```
config firewall address
edit "SSLVPN_TUNNEL_ADDR1" #The address name.
set uuid 1e1315b4-fcbf-51ec-d1be-f59b45e347b9
```

```

set type iprange
set start-ip 10.212.134.200
set end-ip 10.212.134.210
next
end



```

Creating an address group

To create an address group:

1. Go to *Secret Settings > Addresses*.
2. From the **+Create New** dropdown, select *Address Group*.

3. Enter the following information:

Group name	Name of the group.
Members	Select +, and in <i>Select Entries</i> , select a member or create an address or an address group, click <i>Close</i> .
	 Use the search bar to look for a member.
	 Use the pen icon next to the member to edit it.
Comments	Optionally, enter comments about the address group.

4. Click *OK*.

Creating an address group using the CLI - example

1. Enter the following commands in the CLI console:

```

config firewall addrgrp
edit "G Suite" #The address group name.
set uuid 1d22ff2a-fcbf-51ec-442e-9003cableecb
set member "gmail.com" "wildcard.google.com"
next
end

```

Dependency updater

Service accounts

A service account is a non-human privileged account that an operating system uses to run applications, automated services, virtual machine instances, and other background processes.

A service account provides a way to assign an identity and permissions to a computer program or process that performs a specialized task.

Service accounts have privileges that allow extensive access to system resources either locally or across the domain.

While service accounts can be created manually, they are often preinstalled and preconfigured as part of an operating system or another software program.

Service accounts pose a greater risk compared to other privileged accounts as they can potentially enable bad actors to hide in plain sight by operating under the cloak of a valid program. Many such programs run continuously, giving attackers persistent access.

Cybercriminals who hack a service account can elevate privileges to gain ever more access. Adopting a phantom identity allows them to roam freely through corporate IT networks and cloud environments without arousing suspicions.

Updating service accounts

If a service running on a machine relies on a credential managed by FortiPAM, the dependency updater feature offers the ability to update the service credential immediately after FortiPAM changes the credential. FortiPAM ensures that the service does not fail during authentication.

Dependency Updater in *Secret Settings* displays a list of dependency updaters.

A dependency updater defines the service identifier and its type.

For every dependency updater, the following columns are displayed by default:

- *Name*
- *Service Name*
- *Update After Restart*
- *References*

<input type="checkbox"/>	Name	Service Name	Update After Restart	References
<input type="checkbox"/>	test	ActiveX Installer (AxinstSV)	Enabled	0

The *Dependency Updater* tab contains the following options:

Create	Select to create a new dependency updater. See Creating a dependency updater on page 167 .
Search	Enter a search term in the search field, then hit Enter to search the dependency updater list. To narrow down your search, see Column filter .
Edit	Select to edit the selected dependency updater.

Delete

Select to delete the selected the selected dependency updaters.

Clear Selection

Select to clear the currently selected dependency updater entries from selection.



For updating the Windows server, WinRM service must be configured on the target machine, and there must be a privileged account for the target machine in FortiPAM.

See [Updating a service account credential Example](#) on page 168.

Creating a dependency updater

To create a dependency updater:

1. Go to *Secret Settings > Dependency Updater*.
2. Select *Create*.

The *New Dependency Updater* window opens.

3. Enter the following information:

Name

The name of the dependency updater.

Restart After Updates

Enable/disable restarting the service after updating the service credentials (default = disable).

Service Name

Enter a service name or from the dropdown, select a service.

On Windows, the Service *Display name* is different from the *Service name*.

For example, in *Services* on Windows, when you double-click *Application Identity*, you see that the *Service name* is *AppIDSvc*.

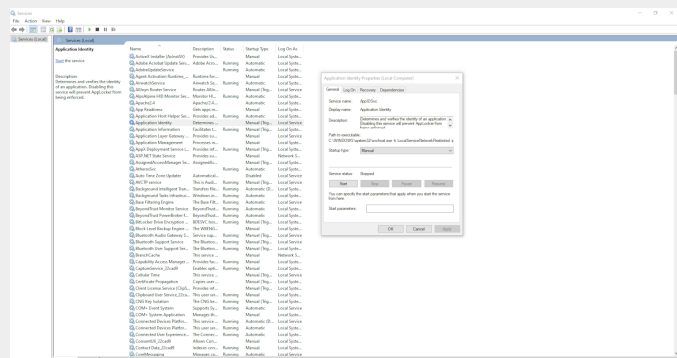

4. Click *Submit*.

Configuring dependency updater via the CLI commands - Example

To configure dependency updater via the CLI commands:

1. In the CLI console, enter the following commands:

```
config secret dependency-updater
edit 'win-mysql-updater'
set type win-service
set restart disable
set service-name 'MySQL80'
next
end
```

Updating a service account credential - Example

To update a service account credential:

1. Go to *Secret Settings > Dependency Updater*.
2. Select *Create*.
The *New Dependency Updater* window opens.
3. In *Name*, enter a name for the dependency updater.
4. Set *Restart After Updates* to *Disable*.

If you intend to restart the service each time after updating the service credential, set *Restart After Updates* to *Enable*.

5. In the *Service Name* dropdown, select *Application Identity*.

On Windows, the Service *Display name* is different from the *Service name*.

For example, in *Services* on Windows, when you double-click *Application Identity*, you see that the *Service name* is *AppIDSvc*.

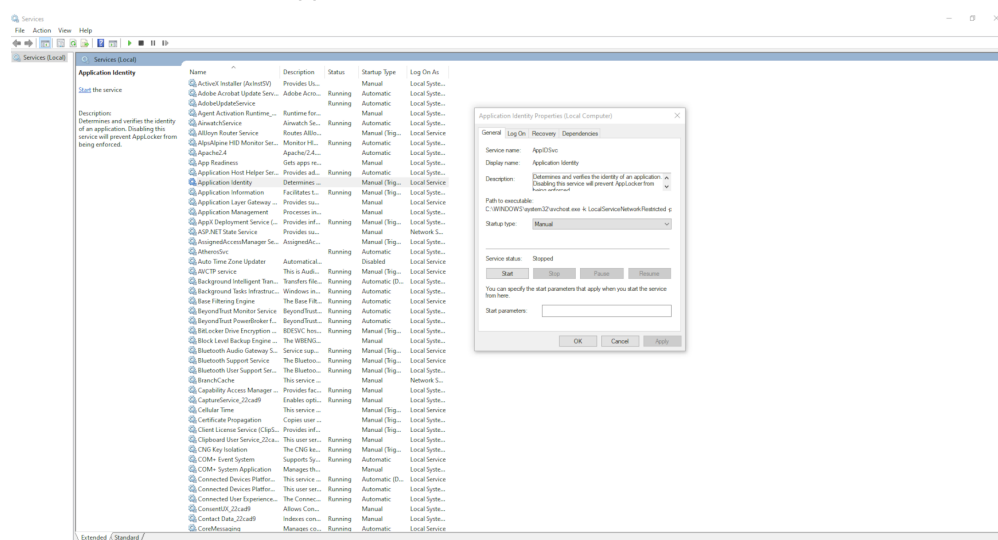

6. Click *Submit*.

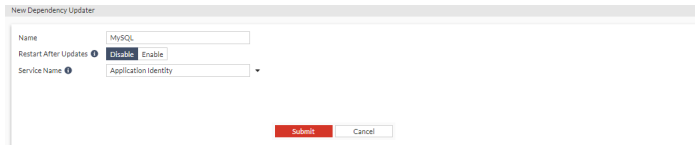

7. Go to *Secrets > Secret List*.

8. Double-click the secret that you intend to use as the credential for a target where the service defined in the dependency updater runs.

9. Select the *Dependency* tab.

10. Select +.

11. From the *Dependency* dropdown, select the dependency updater created earlier.

12. From the *Target* dropdown, select a target.

13. Click *Save*.

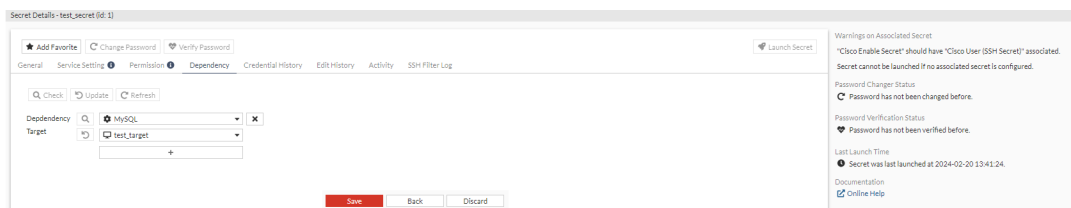



Once the secret password changer successfully rotates the secret password, all the dependencies in the secret are automatically updated.

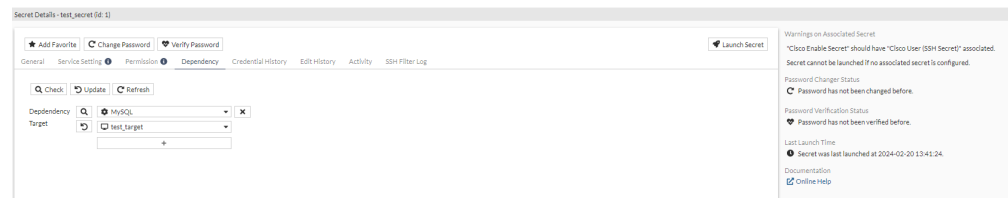

To update an individual dependency, click the *Update Dependency* (↻) icon on the left of each dependency when editing a secret.

If needed, you can update all the dependencies by selecting *Update* from the top when editing the secret.



Click the *Check Dependency* () icon on the left of each dependency to check if the service is running or not, and whether the service is running with the particular secret user name.

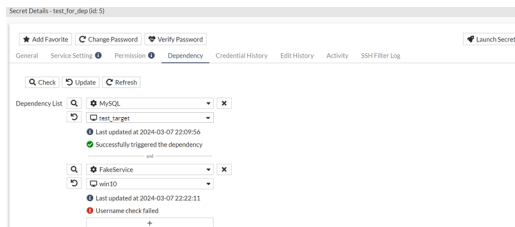

To check all the dependencies in a secret, select *Check* from the top when editing a secret.



To sync the current status of the dependencies, select *Refresh* from the top when editing a secret.

Approval flow

To launch secrets where approval from the members of the approval group(s) is required, an approval profile needs to be set up.



By default, secrets do not require approval to access them. See [Enabling approval profiles for a secret on page 171](#).

The approval profile defines the number of tiers of approvals required for the user to be able to launch the secret. Each tier includes the following information:

- The number of approvals required to pass through the tier.
- The users reviewing the secret request.
- The user groups reviewing the secret request.



FortiPAM supports up to 3 approval tiers.

See [Approval profile on page 171](#).

Approval profile

Go to *Approval Profile* in *Secret Settings* to see a list of the configured approval profiles.

For every approval profile, the following fields are shown:

- *Name*
- *Type*
- *Description*
- *Reference*

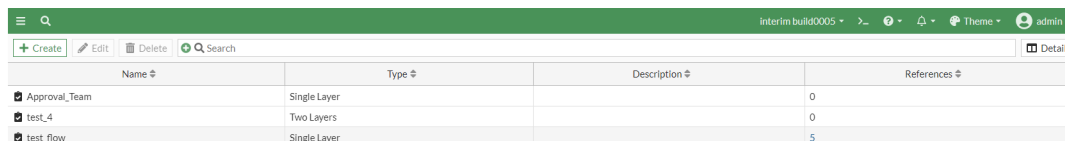

Name	Type	Description	References
Approval_Team	Single Layer		0
test_4	Two Layers		0
test_flow	Single Layer		5



For secret requests, before the request is finalized, a *Deny* action from any member of the approval profile stops the request from going to the subsequent approval tier. The requester is immediately alerted about the denial of the request.

The *Approval Profile* tab contains the following information:

Create	Select to create a new approval profile. See Create an approval profile on page 172 .
Edit	Select to edit the selected approval profile.
Delete	Select to delete the selected profiles.
Search	Enter a search term in the search field, then hit <code>Enter</code> to search the approval profiles list. To narrow down your search, see Column filter .
Details	Select to see details of the selected approval profile.

Enabling approval profiles for a secret

To enable approval profile:

1. Go *Secrets > Secret List*.
2. In *Secret List*, select a secret and then select *Edit*.
The *Secret Details* window opens.
3. In the *Secret Setting* pane, enable *Requires Approval to Launch Secret* to require users to request permission from the approvers defined in the approval profile for secret launching.
Alternatively, enable *Requires Approval to Launch Job* to require users to request permission from the approvers defined in the approval profile for job execution.
4. In the *Approval Profile* dropdown, select an approval profile, or select *Create* to create a new approval profile. See [Create an approval profile on page 172](#).
5. Click *Save*.

Create an approval profile

To create an approval request:

1. Go to *Secret Settings > Approval Profile*.
2. Select *Create* to create a new approval profile.

The *New Approval Profile* window opens.

3. Enter the following information:

Name	The name of the approval profile.
Number of Approval Tiers	The number of approval tiers a secret request is processed through: <ul style="list-style-type: none"> • <i>One</i> (default) • <i>Two</i> • <i>Three</i>
Minimum Permission	From the dropdown, select the minimum secret permission required by the approver to view the secret request: <ul style="list-style-type: none"> • <i>None</i> (default) • <i>List</i> • <i>View</i> • <i>Edit</i> • <i>Owner</i>
Customized Email Template	Enable, and from the dropdown, select a customized email template. See Approval email template on page 175 .
 <p>Use the search bar to look up a custom email template.</p>	

Remote Group Email

Enabling ensures that members of an approver group receive email notification when an access request is sent for a secret where *Requires Approval to Launch Secret* (see [Creating a secret on page 60](#)) is enabled and an approval profile is selected with at least one remote user group as an approver (default = disable).



The option appears when you select at least one remote user group in *Approver Groups*.

The screenshot shows the 'New Approval Profile' configuration page. The 'Remote Group Email' field is set to 'Enable'. The 'Trust Time' field is set to '0'. The 'Tier-1 Settings' section shows 'Required number of Approvals' as '1', 'Approvers' as 'admin', and 'Approver Groups' as 'test'. There are 'Submit' and 'Cancel' buttons at the bottom.

Trust Time

Controls how frequently the remote user needs to log in to FortiPAM to receive the approver email notification.

Enter the number of days from the access request creation time a remote user belonging to the remote user group in *Approver Groups* logs in to FortiPAM (0 - 30, default = 0).

Note: 0 means no login requirements.

For example, when *Trust Time* is 5, a remote user belonging to the remote user group selected in *Approver Groups* must have logged in to FortiPAM at least once within five days from the access request creation time to receive the approver email notification.



The field appears when *Remote Group Email* is enabled.

	<div data-bbox="873 226 954 331" data-label="Image"></div> <p data-bbox="976 233 1406 327"><i>Trust Time</i> filters out remote users who are not disabled/removed on FortiPAM but are removed from the IdP.</p> <hr/> <div data-bbox="873 415 954 520" data-label="Image"></div> <p data-bbox="976 394 1386 554">If the approving user logs in to FortiPAM before the access request expires, the user can still approve the access request, but no email notification is sent.</p>
<p>Description</p>	<p>Optionally, enter a description.</p>
<p>Tier-1 Settings</p>	
<div data-bbox="289 722 370 827" data-label="Image"></div>	<p>Tier 2 and 3 options are same as tier 1.</p>
<p>Required number of Approvals</p>	<p>The minimum number of approvals required.</p> <hr/> <div data-bbox="634 947 716 1052" data-label="Image"></div> <p data-bbox="760 940 1414 1068">The number of user or user groups reviewing a secret request as part of an approval profile must be at least equal to the number of approvals required to pass the request to the next tier or approve it.</p>
<p>Approvers</p>	<p>Select + and from the list, select users in the <i>Select Entries</i> window. The selected users will review the secret request.</p> <p>To add a new user:</p> <ol style="list-style-type: none"> 1. From the <i>Select Entries</i> window, select <i>Create</i>. The <i>New User List</i> wizard opens. 2. Follow the steps in Creating a user on page 218, starting step 2 to create a new user. <hr/> <div data-bbox="623 1457 721 1562" data-label="Image"></div> <p data-bbox="760 1499 1166 1524">Use the search bar to look up a user.</p>
<p>Approver Groups</p>	<p>Select + and from the list, select user groups in the <i>Select Entries</i> window. The selected user groups will review the secret request.</p> <p>To add a new user group:</p> <ol style="list-style-type: none"> 1. From the <i>Select Entries</i> window, select <i>Create</i>. The <i>Create New User Group</i> window opens.

2. Follow the steps in [Creating user groups](#), starting step 3.



Use the search bar to look up a user group.

4. Click *Submit*.

Approval email template

Approval Email Template in *Secret Settings* displays a list of secret approval request email templates.

You can create a custom email template for the secret approval request email sent to the approvers.



Custom email templates can be created in the GUI or the CLI console.

For every approval email template, the following columns are displayed by default:

- *Name*
- *Subject*
- *Content*

When you select an email template, a preview of the selected email template is displayed on the right.

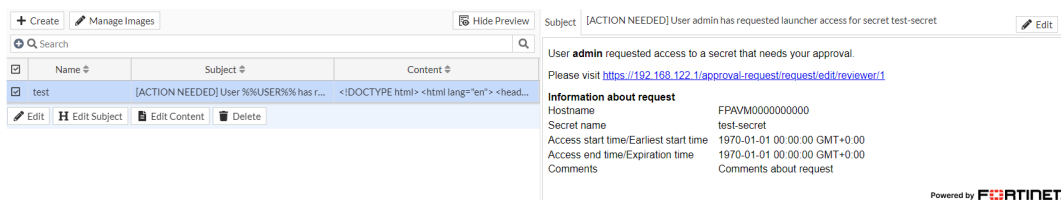

Approval email template list contains the following options:

Create	Select to create an approval email template. See Creating an approval email template on page 176 .
Manage Images	Select to view the available images and their respective tags and add new images. By default, images are embedded in the approval email template instead of using a URL. See Managing images on page 364 .
Hide/Show Preview	Select to hide or show the selected approval email template preview.
Search	Enter a search term in the search field, then hit Enter to search the approval email template list. To narrow down your search, see Column filter .
Edit	Select to edit the selected approval email template.

Edit Subject	Select to edit the subject of the selected approval email template.
Edit Content	Select to edit the content of the selected approval email template.
Delete	Select to delete the selected approval email template.

To create an approval email template using the CLI console, see [Creating an approval email template using the CLI on page 179](#).

Creating an approval email template

To create an approval email template:

1. Go to *Secret Settings > Approval Email Template*.
2. Select *Create*.

The *New Approval Email Template* window opens.

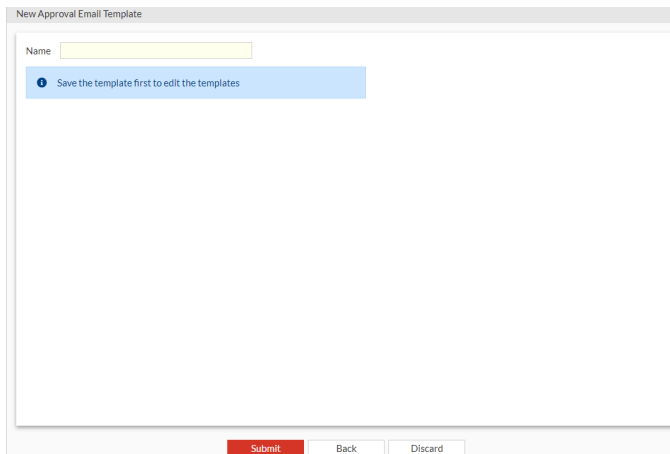

3. In *Name*, enter a name for the approval email template.
4. Click *Submit*.



You must save the approval email template first to be able to edit the template.

The *Edit Approval Email Template* window opens.

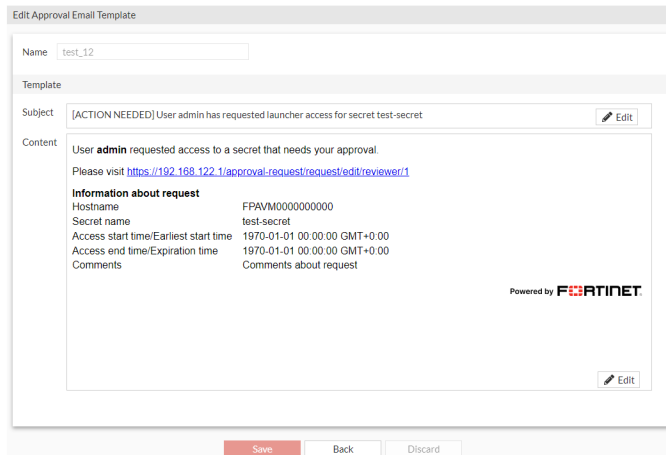

5. In the *Template* pane:
 - a. In *Subject*, select *Edit*.
The *Edit Subject of Email Template Name* window opens.



The subject must be text only.

By default, the preview and the plain text code are displayed as a horizontally split screen.

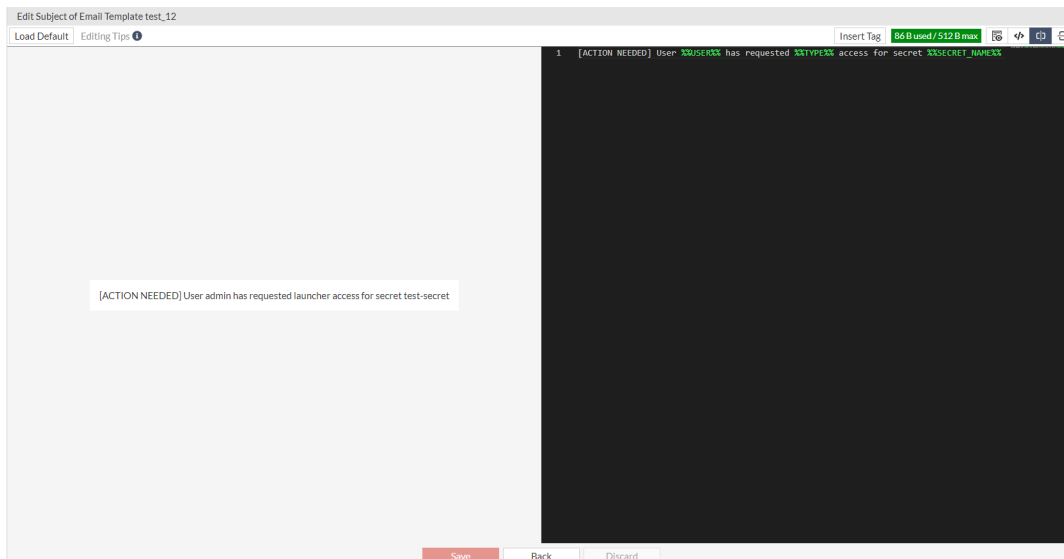

Click the insert buttons to add variable, image tags, or:





- Enter %% to show all the available variables.
- Hit **Ctrl + Space** to display the auto-completion pane.
- Use the preview pane to preview the changes in realtime.



Select *Load Default* to load the default entry.



From the options on the right, select:

- *Preview* (): Preview the subject.
- *Editor* (): Open the plain text code editor.
- *Horizontal Split* (): Editor and preview screens are horizontally split.
- *Vertical Split* (): Editor and preview screens are vertically split.

b. Edit the plain text code.

c. To insert a tag:

- i. In the plain text code where you intend to add a tag, select *Insert Tag*.
Alternatively, enter %% to show all the variables.

- ii. From the list that appears, select a tag.

d. Click Save.

e. In *Content*, select *Edit*.

The *Edit Content of Email Template Name* window opens.

f. Edit the plain text code.

g. To insert tag, follow [step c](#).

h. To insert an image:

- i. In the plain text code where you intend to add an image, select *Insert Image*.
The cursor goes to %%IMAGE : , a list of all the images with preview appears.



Alternatively, enter %%IMAGE : .

- ii. Select an image from the list.



The email maximum size is 192 KB, including all images. If the email is too large, FortiPAM truncates it to fit within the size limit.

i. Click Save.

6. Click Save.



The approval email template can now be added to an approval profile. See [Create an approval profile on page 172](#).

Creating an approval email template using the CLI

To create an approval email template:

1. In the CLI console, use the following commands:

```
config secret approval-email-template
edit "test-template"
set subject "User %%USER%% has requested access to secret %%SECRET_ID%%"
set content "TEST EMAIL
Approval url: %%APPROVAL_URL%%
Request id: %%REQUEST_ID%%
Secret url: %%SECRET_URL%%
Secret id: %%SECRET_ID%%
Secret name: %%SECRET_NAME%%
Job name: %%JOB_NAME%%
Start time: %%START_TIME%%
End time: %%END_TIME%%
Hostname: %%HOSTNAME%%
User: %%USER%%
"
next
end
```

Variable	Description
%%TYPE%%	launcher or job depending on the type of the request.
%%APPROVAL_URL%%	The URL to access the secret approval page to approve/deny the request.
%%REQUEST_ID%%	The request ID in the configuration management database.
%%SECRET_URL%%	The URL to access secret information.
%%SECRET_ID%%	The secret ID in the configuration management database.
%%SECRET_NAME%%	The name of the secret.
%%JOB_NAME%%	The name of the job (empty for a secret request).
%%START_TIME%%	The time allowed to begin launching the secret or the earliest execution time for the job request.
%%END_TIME%%	The time after which you cannot launch the secret or the request approval expiration time for the job request.
%%HOSTNAME%%	FortiPAM name/ID.

Variable	Description
%%COMMENTS%%	Comments by the requester.
%%USER%%	User name.
%%IMAGE :	Custom image.

Password changers

A password changer can be configured for a custom secret template to periodically change the password of a secret and periodically check the health of a secret.

For each password changer; name, type, changers, verifiers, change mode, verify mode, description, and references are displayed.

Name	Type	Changers	Verifiers	Change Mode	Verify Mode	Description	References
Active Directory LDAPS	Active Directory LDAP			Self	Self		1
Cisco Enable Secret	SSH with Password	Expect Prompt >_... Execute >_ enable Expect >_ Password: Execute >_ \$PASSW... 25	Expect Prompt >_... Execute >_ enable Expect >_ Password: Execute >_ \$PASSW... Expect >_ #	Association	Association		1
Cisco User (SSH Secret)	SSH with Password	Expect Prompt >_... Execute >_ enable Expect >_ Password: Execute >_ \$[0].SPAS... 25		Self	Self		1
Cisco XR Router	SSH with Password	Expect Prompt >_... Execute >_ configure... Expect >_ (config)# Execute >_ username ... 25		Self	Self		1
ESXi Password	SSH with Password	Expect >_ ~] Execute >_ passwd Expect >_ password: Execute >_ \$NEWPPA... 25		Self	Self		1
ESXi Web	Web-API			Self	Self		1
Open LDAPS	Open LDAP			Self	Self		1
SSH Key (FortiProduct)	SSH with Public Key	Expect >_ to accept): Execute >_ a Expect Prompt >_... Execute >_ config glo... 25		Self	Self		1
SSH Key (Unix)	SSH with Public Key	Expect Prompt >_... Execute >_ cd Expect Prompt >_... Execute >_ mkdir -p .s... 25		Self	Self		1
SSH Password (FortiProduct)	SSH with Password	Expect >_ to accept): Execute >_ a Expect Prompt >_... Execute >_ config glo... 25		Self	Self		1
SSH Password (Unix)	SSH with Password	Expect Prompt >_... Execute >_ passwd Expect >_ password: Execute >_ \$PASSW... 25		Self	Self		1
Samba	Samba			Self	Self		2

FortiPAM offers the following default password changers:

- Active Directory LDAPS
- Cisco Enable Secret
- Cisco User (SSH Secret)
- Cisco XR Router
- ESXi Password
- ESXi Web
- Open LDAPS
- SSH Key (FortiProduct)
- SSH Key (Unix)

- SSH Password (FortiProduct)
- SSH Password (Unix)
- Samba



Default password changers cannot be edited.



Custom password changers are clones of their default counterparts and are editable.

For LDAPS password changer and verification, the minimum SSL/TLS version and the target server port number used by LDAPS can be set using the following CLI commands, provided the secret has an associated target:

```
config secret target
  edit target_name
    set ldaps-min-ssl-version {default | SSLv3 | TLSv1 | TLSv1.1 | TLSv1.2 | TLSv1.3}
    set ldaps-port <integer>
  end
end
```



If there is no associated target with the secret or `ldaps-min-ssl-version` is set to `default`, the minimum SSL/TLS version used follows `system > global > ssl-min-ssl-version`.

The *Password Changers* tab in *Secret Settings* contains the following options:

Create	Select to create a new password changer. See Creating a password changer on page 181 .
Edit	Select to edit the selected password changer.
Delete	Select to delete the selected password changers.
Clone	Select to clone the selected password changer.
Search	Enter a search term in the search field, then hit <code>Enter</code> to search the password changers list. To narrow down your search, see Column filter .

Creating a password changer

To create a password changer:

1. Log in to FortiPAM with an account that has sufficient permission to create a password changer.
2. Go to *Secret Settings > Password Changers*.
3. Select *Create* to create a new password changer.
The *New Password Changer* window opens.

New Password Changer

Name

Type

New Line Mode

Change Auth Mode

Verify Auth Mode

Description

Changers



Sequence	Type	Command	Action	Critical	Delay (ms)	Description
No results						
0						

Verifiers

Sequence	Type	Command	Action	Critical	Delay (ms)	Description
No results						
0						

4. Enter the following information:

Name	The name of the password changer.
Type	From the dropdown, select a type: <ul style="list-style-type: none"> • <i>Active Directory LDAP</i> • <i>Open LDAP</i> • <i>Samba</i> • <i>SSH with Public Key</i> • <i>SSH with Password (default)</i>
New Line Mode	Select from the following options: <ul style="list-style-type: none"> • <i>CR (\r)</i>: Carriage Return (\r) • <i>CRLF (\r\n)</i>: Carriage Return and Line Feed (\r\n) (default) • <i>LF (\n)</i>: Line Feed (\n)
Change Auth Mode	Select from the following two options: <ul style="list-style-type: none"> • <i>Association</i>: Changing password requires credentials from the associated secret. See <i>Associated Secret</i> option when Creating a secret on page 60. • <i>Self</i>: Secret can change its password (default).
Verify Auth Mode	Select from the following two options: <ul style="list-style-type: none"> • <i>Association</i>: Verifying password requires credentials from the associated secret. See <i>Associated Secret</i> option when Creating a secret on page 60. • <i>Self</i>: Secret can verify its password (default).
Description	Optionally, enter a description.
Changers	The password changing procedure. See Changers .

	The option is available only when the <i>Type</i> is <i>SSH with Public Key</i> or <i>SSH with Password</i> .
Verifiers	The password verification procedure. See Verifiers .
	The option is available only when the <i>Type</i> is <i>SSH with Public Key</i> or <i>SSH with Password</i> .

5. Click *Submit*.

Changers

1. In step 4 when [Creating a password changer](#), select *Create* in *Changers*. The *New Procedure* window opens. By default, the *Type* is *Execute*.

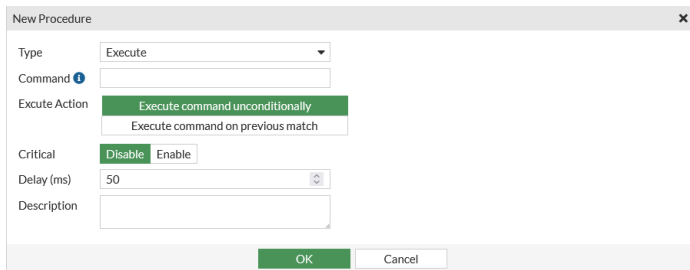

The screenshot shows the 'New Procedure' dialog box with the following configuration:

- Type: Execute
- Command: (empty)
- Execute Action: Execute command unconditionally (selected), Execute command on previous match
- Critical: Disable (selected), Enable
- Delay (ms): 50
- Description: (empty)

Different configuration options are available according to the *Type* selected.

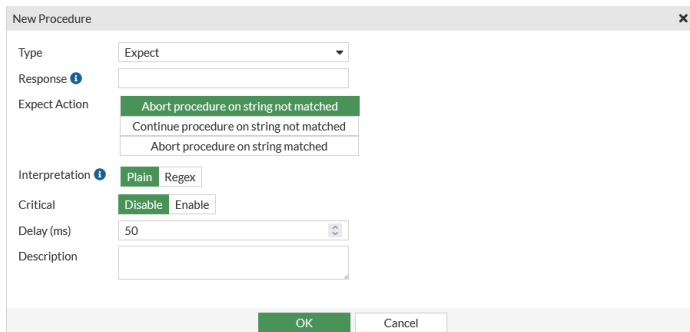

The screenshot shows the 'New Procedure' dialog box with the following configuration:

- Type: Expect
- Response: (empty)
- Expect Action: Abort procedure on string not matched (selected), Continue procedure on string not matched, Abort procedure on string matched
- Interpretation: Plain (selected), Regex
- Critical: Disable (selected), Enable
- Delay (ms): 50
- Description: (empty)

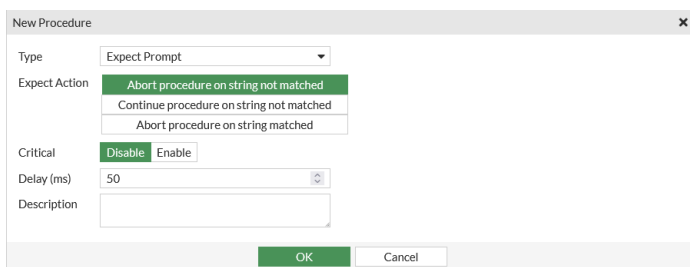



The screenshot shows the 'New Procedure' dialog box with the following configuration:

- Type: Expect Prompt
- Expect Action: Abort procedure on string not matched (selected), Continue procedure on string not matched, Abort procedure on string matched
- Critical: Disable (selected), Enable
- Delay (ms): 50
- Description: (empty)

2. Enter the following information:

Type	From the dropdown, select from the following options:
-------------	---

	<ul style="list-style-type: none"> • <i>Execute</i> • <i>Expect</i> • <i>Expect Prompt</i>
Command	<p>Commands to execute on the password changer.</p> <p>Valid variables are:</p> <ul style="list-style-type: none"> • \$USER • \$PASSWORD • \$PASSPHRASE • \$NEWPASSWD • \$NEW_PUB_KEY • \$NEW_PRI_KEY • \$[0].\$ • \$PUB_KEY <p>Note: \$[0].\$ could be used when an associated secret is used. In this case, \$[0].\$USER means the username of the associated secret. \$[0].\$PASSWORD means the password of the associated secret.</p> <hr/> <div style="display: flex; align-items: center;">  <p>Enter \$ to get the list of valid variables.</p> </div> <hr/> <p>Note: The option is only available when the <i>Type</i> is <i>Execute</i>.</p>
Response	<p>The prompted line in target server.</p> <hr/> <div style="display: flex; align-items: center;">  <p>Enter \$ to get the list of valid variables.</p> </div> <hr/> <p>Note: The option is only available when the <i>Type</i> is <i>Expect</i>.</p>
Execute Action	<p>Either select <i>Execute command unconditionally</i> or <i>Execute command on previous match</i>.</p> <p>Note: The option is only available when the <i>Type</i> is <i>Execute</i>.</p>
Expect Action	<p>From the dropdown, select from the following three options:</p> <ul style="list-style-type: none"> • <i>Abort procedure on string not matched</i> • <i>Continue procedure on string not matched</i> • <i>Abort procedure on string matched</i> <p>Note: The option is only available when the <i>Type</i> is <i>Expect</i> or <i>Expect Prompt</i>.</p>
Interpretation:	<p>Select the method to interpret the expect string.</p> <ul style="list-style-type: none"> • <i>Plain:</i> Interpret the expect string as a plain command. • <i>Regex:</i> Interpret the expect string as a regular expression. For example, if the response is "Current password:", then all of "Current", "password", "rent" will succeed to match. <p>Note: The option is only available when the <i>Type</i> is <i>Expect</i>.</p>

Critical	Enable to indicate that the step is critical.
	 Password changing is successful when all steps before the critical step are passed. Steps after the critical step are optional, password changer ignores the optional steps if they fail.
Delay (ms)	The maximum waiting time for the current action, in ms (default = 50, 50 - 20000).
Description	Optionally, enter a description.



To reorder the changer sequence, drag from the sequence number and then drop.

3. Click **OK**.



From the list, select a changer and then select *Edit* to edit the changer.
 From the list, select changer and then select *Delete* to delete the changer.

Verifiers

1. In step 4 when [Creating a password changer](#), select *Create* in *Verifiers*. The *New Procedure* window opens. By default, the *Type* is *Execute*.



The screenshot shows the 'New Procedure' dialog box. The 'Type' dropdown is set to 'Execute'. The 'Command' field is empty. Under 'Execute Action', there are two options: 'Execute command unconditionally' (highlighted in green) and 'Execute command on previous match'. The 'Critical' section has 'Disable' and 'Enable' buttons, with 'Enable' selected. The 'Delay (ms)' is set to 50. The 'Description' field is empty. At the bottom, there are 'OK' and 'Cancel' buttons.

Different configuration options are available according to the *Type* selected.

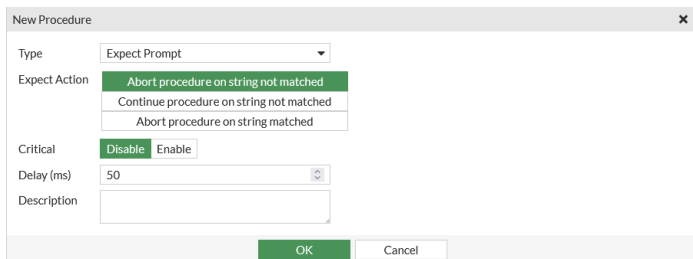
The screenshot shows the 'New Procedure' dialog box with 'Type' set to 'Expect'. The 'Response' field is empty. Under 'Expect Action', there are three options: 'Abort procedure on string not matched' (highlighted in green), 'Continue procedure on string not matched', and 'Abort procedure on string matched'. The 'Interpretation' section has 'Plain' and 'Regex' buttons, with 'Plain' selected. The 'Critical' section has 'Disable' and 'Enable' buttons, with 'Enable' selected. The 'Delay (ms)' is set to 50. The 'Description' field is empty. At the bottom, there are 'OK' and 'Cancel' buttons.



2. Enter the following information:

Type	<p>From the dropdown, select from the following options:</p> <ul style="list-style-type: none"> • <i>Execute</i> • <i>Expect</i> • <i>Expect Prompt</i>
Command	<p>Commands to execute on the password changer.</p> <p>Valid variables are:</p> <ul style="list-style-type: none"> • \$USER • \$PASSWORD • \$PASSPHRASE • \$NEWPASSWD • \$NEW_PUB_KEY • \$NEW_PRI_KEY • \$[0].\$ • \$PUB_KEY <p>Note: \$[0].\$ could be used when an associated secret is used. In this case, \$[0].\$USER means the username of the associated secret. \$[0].\$PASSWORD means the password of the associated secret.</p> <hr/> <p> Enter \$ to get the list of valid variables.</p> <hr/> <p>Note: The option is only available when the <i>Type</i> is <i>Execute</i>.</p>
Response	<p>The prompted line in target server.</p> <hr/> <p> Enter \$ to get the list of valid variables.</p> <hr/> <p>Note: The option is only available when the <i>Type</i> is <i>Expect</i>.</p>
Execute Action	<p>Either select <i>Execute command unconditionally</i> or <i>Execute command on previous match</i>.</p> <p>Note: The option is only available when the <i>Type</i> is <i>Execute</i>.</p>
Expect Action	<p>From the dropdown, select from the following three options:</p> <ul style="list-style-type: none"> • <i>Abort procedure on string not matched</i>

	<ul style="list-style-type: none"> • <i>Continue procedure on string not matched</i> • <i>Abort procedure on string matched</i> <p>Note: The option is only available when the <i>Type</i> is <i>Expect</i> or <i>Expect Prompt</i>.</p>
Critical	Enable to indicate that the step is critical.
	 Password verification is successful when all steps before the critical step are passed. Steps after the critical step are optional, password verifier ignores the optional steps if they fail.
Delay	The maximum waiting time for the current action, in ms (default = 50, 50 - 20000).
Description	Optionally, enter a description.



To reorder the verifier sequence, drag from the sequence number and then drop.

3. Click *OK*.



From the list, select a verifier and then select *Edit* to edit the verifier.
From the list, select verifier and then select *Delete* to delete the verifier.

See [Automatic password changing on page 187](#) and [Automatic password verification on page 188](#).

Automatic password changing

A password changer linked to a secret template can be activated to periodically change the password in a secret that uses this secret template.

To automatically change the password:

1. Go to *Secrets > Secret List*.
Alternatively, go to *Secrets > Personal Folder/Public Folder*, and select the folder where the secret is located.
2. Double-click the secret to edit it.
3. In the *Secret Setting* pane:
 - a. Enable *Automatic Password Changing*.
 - b. In *Start Time*, enter the date and time when the recurring schedule begins. Alternatively, select the *Calendar* icon and then select a date and time.
 - c. In *Recurrence*, select from the following three frequencies of recurrence:
 - i. *Daily*
 - ii. *Weekly*
 - iii. *Monthly*
 - d. In *Repeat every*, enter the number of days/weeks/months after which the password is changed.

- e. In *Occurs on*, select from the following days of the month when the password is automatically changed:
 - i. *First*
 - ii. *Second*
 - iii. *Third*
 - iv. *Last*
 - v. *Last Day*
 - vi. *Day*

When you select *Day*, select + to add days of the month when the password is automatically changed.

Select days of the week when the password is automatically changed.

Note: The *Occurs on* option is only available when *Recurrence* is set as *Weekly* or *Monthly*.

The automatic password changing schedule is displayed in *Recursive*.

4. Click **Save**.



If *Automatic Password Changing* is enabled then the *Password Changer Status* shows the amount of time after which the password is automatically changed.

Automatic password verification

A password changer linked to a secret template can be activated to periodically verify the password, and check if the target server is still available for a secret that uses this secret template.

To automatically verify the password:

1. Go to *Secrets > Secret List*.
Alternatively, go to *Secrets > Personal Folder/Public Folder*, and select the folder where the secret is located.
2. Double-click the secret to edit it.
3. In the *Secret Setting* pane:
 - a. Enable *Automatic Password Verification*.
 - b. In *Interval (min)*, enter the time interval at which the password is verified.
 - c. In *Start Time*, enter a date and time.
Alternatively, select the calendar icon, and select a date and time.
4. Click **Save**.



If *Automatic Password Verification* is enabled then the *Password Verification Status* shows the amount of time after which the password is automatically verified.

Password policies

Using a secure password is vital to prevent unauthorized access. FortiPAM allows you to create password policy for secret passwords generated by the password changer. See [Password changers on page 180](#).

With password policies, you can enforce specific criteria for a new password, including:

- Minimum length between 8 and 64 characters.
- Maximum length up to 64 characters.
- The password must contain uppercase (A, B, C) and/or lowercase (a, b, c) characters.
- The password must contain numbers (1, 2, 3).
- The password must contain special or non-alphanumeric characters (!, @, #, \$, %, ^, &, *, (, and)).



Password policies can only be applied to a secret template when *Password Changer* is enabled for the template.



Password policies are not applicable to SSH keys (*Password changer Type* is *SSH with Public Key*).

For each password policy; name, password requirement, minimum length, maximum length, and references are displayed.

Name	Password Requirement	Minimum Length	Maximum Length	References
default	3 lower 3 upper 2 symbol 2 number	10	20	0

The default password policy has the following features:

- *Minimum length*: 10
- *Maximum length*: 20
- *Password Requirements*: 3, 3, 2, and 2 minimum number of characters from the *lower*, *upper*, *symbol*, and *number* character sets respectively. See [Character sets on page 191](#).

The *Password Policies* tab contains the following options:

Create	Select to create a new password policy. Password policies on page 188 .
Edit	Select to edit the selected password policy.
Delete	Select to delete the selected password policies.
Search	Enter a search term in the search field, then hit <code>Enter</code> to search the password policies list. To narrow down your search, see Column filter .

Creating a password policy

To create a password policy:

1. Go to *Secret Settings > Password Policies*
2. Select *Create* to create a new password policy.
The *Create Password Policy* window opens.

3. Enter the following information:

Name	The name of the password policy.
Minimum Length	The minimum length of the password (default = 8).
Maximum Length	The maximum length of the password (default = 16).
Password Requirements	The requirements for the password to be successfully created. See Password Requirements .

4. Click *OK*.

Password Requirements

1. In step 2 when [Creating a password policy](#), select *Create in Password Requirements*. The *New Password Requirement* window opens.

- Enter the following information:

Minimum Number	The minimum number of characters from the <i>Character Set</i> (default = 1).
-----------------------	---

Character Set	From the dropdown, select a character set or create a new character set (default = lower). See Creating a character set on page 192 .
----------------------	---



Use the search bar to look up a character set.



Use the pen icon next to the character set to edit it.

- Click *OK*.



From the list, select a requirement and then select *Edit* to edit the requirement.
From the list, select requirements and then select *Delete* to delete the requirements.

See [Applying a password policy to a secret template on page 191](#).

Applying a password policy to a secret template

To apply a password policy to a secret template:

- Go to *Secret Settings > Templates*.
- From the list, double-click a secret template to edit the template.
Alternatively, select a template and then select *Edit* to edit the template.
The *Edit Secret Template* window opens.



Default templates cannot be modified.
Administrators can clone a default template and then select a password policy.

- In the *Password Changer* pane, from the *Password Policy* dropdown, select a password policy or create a new password policy. See [Creating a password policy on page 189](#) and [Creating secret templates on page 137](#).
- Click *Save*.

Character sets

A character set is a group of varied characters used in password policies. Character sets provide building blocks for passwords. See [Password policies on page 188](#).

Character Sets in *Secret Settings* displays a list of configured character sets.

For each character set; name, character set, and references are displayed.

Name	Character Set	References
lower	abcdefghijklmnopqrstuvwxyz	1
number	1234567890	1
symbol	~!@#\$%^&*()_+=[\]{} :;<->./	1
upper	ABCDEFGHIJKLMNOPQRSTUVWXYZ	1

The following default character sets are available in FortiPAM:

- *symbol*: contains some special characters.
- *number*: contains all numbers.
- *lower*: contains all lowercase English letters.
- *upper*: contains all uppercase English letters.

The *Character Sets* tab contains the following options:

Create	Select to create a new character set. See Creating a character set on page 192 .
Edit	Select to edit the selected character set.
Delete	Select to delete the selected character sets.
Search	Enter a search term in the search field, then hit <code>Enter</code> to search the character sets list. To narrow down your search, see Column filter .

Creating a character set

To create a character set:

1. Go to *Secret Settings > Character Sets*.
2. Select *Create* to create a new character set.

The *New Character Set* window opens.

New Character Set

Name

Character Set

OK Cancel

3. Enter the following information:

Name	The name of the character set.
Character Set	The character set.

4. Click *OK*.

AntiVirus

FortiPAM offers the unique ability to prevent, detect, and remove malware when you transfer files between local PCs and privileged servers. FortiPAM will detect the potential malware uploaded to or downloaded from the related secret server if a secret is configured with an antivirus profile. Examples of file launchers include WinSCP, Web SMB, and Web SFTP.

For each antivirus profile; name, comments, and references are displayed.

Name	Comments	Ref.
default	Scan files and block viruses.	0



A *default* antivirus profile is available that blocks malware transmission.

Once configured, you can add the antivirus profile to a secret. See [Enabling antivirus scan in a secret on page 194](#).

You can also customize these profiles or create your profile to inspect specific protocols, remove viruses, analyze suspicious files with FortiSandbox, and apply botnet protection to network traffic. Note that for *Web SMB* and *Web SFTP* launchers, you must inspect the HTTP protocol in the AV profile. While for *WinSCP* launcher, SSH protocol needs to be inspected.

The *AntiVirus* tab contains the following options:

Create New	Select to create a new antivirus profile. See Creating an antivirus profile on page 193 .
Edit	Select to edit the selected antivirus profile.
Clone	Select to clone the selected antivirus profile.
Delete	Select to delete the selected antivirus profiles.
Search	Enter a search term in the search field, then hit <code>Enter</code> to search the antivirus profile list.

Creating an antivirus profile

To create an antivirus profile:

- Go to *Secret Settings > AntiVirus* and select *Create New* to create a new antivirus profile. The *Create AntiVirus Profile* window opens.

Create AntiVirus Profile

Name:

Comments:

AntiVirus Scan Service

Protocol	Disable	Block	Monitor
HTTP	<input type="radio"/>	<input type="radio"/>	<input checked="" type="radio"/>
SSH	<input type="radio"/>	<input type="radio"/>	<input checked="" type="radio"/>

Disable
Disable virus scanning and monitoring.

Block
When a virus is detected, prevent transferring the infected files between the user and the target server.

Monitor
When a virus is detected, a security log will be recorded although the infected files are allowed.

Security Log
When a protocol is blocked or monitored, corresponding logs will be recorded to the Log & Report-> ZTNA page.

Additional Information

API Preview

OK Cancel

2. Enter the following information:

Name	The name of the antivirus profile.
Comments	Optionally, enter comments about the antivirus profile.

AntiVirus Scan Service

For *HTTP* and *SSH* protocols, set the antivirus service as disable, block, or monitor (default = *Disable*):

- *Disable*: Disable antivirus scanning and monitoring.
- *Block*: When a virus is detected, prevent the infected files from uploading to or downloading from the target server. A security log is recorded and available in *Log & Report > ZTNA*.
- *Monitor*: When a virus is detected, allow the infected files. A security log is recorded and available *Log & Report > ZTNA*.

Notes:

- HTTP protocol applies to *Web SFTP* and *Web SMB* launchers.
- SCP protocol applies to the *WinSCP* launcher.

3. Click *OK*.

AV protection via the CLI - Example

1. In the CLI console, enter the following commands:

```
config antivirus profile
  edit <profile-name>
    config http
      set av-scan block
    end
  config ssh
    set av-scan block
  end
next
end
```

Enabling antivirus scan in a secret

To enable antivirus scan in a secret:

1. Go to *Secrets > Secret List*.
2. In the *Secrets List*, double-click a secret to open.
Alternatively, in *Secrets > Personal Folder/Public Folder*, go to the folder where the secret is located, and double-click the secret to open.



If the secret does not show up, it may be because you do not have the necessary permission to access the secret or the folder where the secret is located.

3. In the *Secret Setting* pane, enable *Antivirus Scan*.
4. From the *Antivirus Profile* dropdown, select an antivirus profile. See [Creating an antivirus profile on page 193](#).

5. Click Save.

interim build0014

Edit Secret

General Service Setting Secret Permission Credential History

★ Add Favorite Change Password Verify Password Launch Secret

Name: web-SMB-AD-80.208

Folder: Windows

Template: Windows Domain Account (Samba)

Associated Secret: No associated secret

Description:

ID	Name	Value
1	Domain-Controller	192.168.80.208
2	Username	admin
3	Password	hidden
4	Domain	fortipam.ca

Secret Setting

Automatic Password Changing: Disable Enable

Automatic Password Verification: Disable Enable

Session Recording: Disable Enable

Proxy Mode: Disable Enable

Tunnel Encryption: Disable Enable

Antivirus Scan: Disable Enable

Antivirus Profile: default

Requires Checkout: Disable Enable

Requires Approval to Launch Secret: Disable Enable

Requires Approval to Launch Job: Disable Enable

Save Back Undo Changes

Password Changer Status: Password has not been changed before.

Password Verification Status: Password was last verified at 2023-01-13 16:38:03. Password was verified successfully.

Data loss prevention (DLP) protection for secrets



DLP is available for secret launching only when you have a valid Advanced Malware Protection (AVDB & DLP) license.

DLP, or Data Loss Prevention, is a cybersecurity solution that detects and prevents data breaches. Since it blocks the extraction of sensitive data, users can use it for internal security and regulatory compliance.

The filters in a DLP sensor can examine traffic for the following:

- Known files using DLP fingerprinting
- Known files using DLP watermarking
- Particular file types
- Particular file names

- Files larger than a specified size
- Data matching a specified regular expression

DLP is primarily used to stop sensitive data from leaving your network. DLP can also prevent unwanted data from entering your network and archive some or all of the content that passes through the FortiPAM. DLP archiving is configured per filter, which allows a single sensor to archive only the required data. You can configure the DLP archiving protocol on the GUI and via the CLI.

The following basic filter types can be configured on the GUI and via the CLI:

- **File type and name:** A file type filter allows you to block, allow, log, or quarantine based on the file type specified in the file filter list. See [Supported file types on page 200](#).
- **File size:** A file size filter checks for files that exceed the specific size and performs the DLP sensor's configured action on them.
- **Regular expression:** A regular expression filter filters files or messages based on the configured regular expression pattern.

Data Leak Prevention in *Secret Settings* displays a list of configured DLP sensors.

For each DLP sensor; name, comments, and reference are shown.

Name	Comments	Ref.
DLP All_Executables		0
DLP Content_Archive		0
DLP Content_Summary		0
DLP Large_File		0

FortiPAM offers the following preconfigured DLP sensors:



- **All_Executables:** Includes a DLP filter rule that filters all the available protocols by their file types.
- **Content_Archive**
- **Content_Summary**
- **Large_Files:** Includes a DLP filter rule that filters all the available protocols by their file sizes.



You cannot delete the default DLP sensors.

The *Data Leak Prevention* tab contains the following options:

Create New	Select to create a new DLP sensor. See Creating a DLP sensor on page 197 .
Edit	Select to edit the selected DLP sensor.
Clone	Select to clone the selected DLP sensor.
Delete	Select to delete the selected DLP sensors.
Search	Search the DLP sensors list.

Creating a DLP sensor

To create a DLP sensor:

1. Go to *Secret Settings > Data Leak Prevention*.
2. From the DLP sensors list, select *Create New*.

The *New DLP Sensor* window opens.

3. Enter the following information:

Name	Name of the DLP sensor.
Comments	Optionally, enter a description for the DLP sensor.
DLP Log	Enable to generate a log entry when data matches the configured patterns.
	 The option is enabled by default.
Rules	Create or edit DLP filter rules. See Creating DLP filter rules on page 197 .

4. Click *OK*.

Creating DLP filter rules



Use the search bar to look up a DLP filter rule.

To create a DLP filter rule:

1. In step 2 when [Creating a DLP sensor on page 197](#), select *Create New* in *Rules*. The *Create New Dlp Filter Rule* window opens.

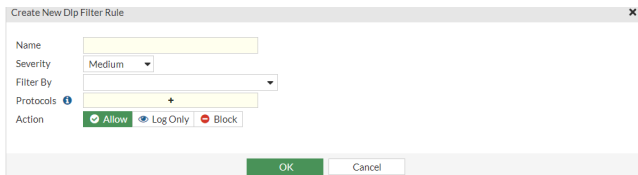

2. Enter the following information:

Name	Name of the DLP filter rule.
Severity	Select a severity for the DLP filter rule: <i>Information, Low, Medium, High, or Critical.</i>
Filter By	Select the filter from the dropdown list: <ul style="list-style-type: none"> • <i>credit-credit (Match Credit Card Numbers)</i> • <i>ssn (Match Social Security Numbers)</i> • <i>regex (Match a Regular Expression)</i> • <i>file-type (Match a DLP File Pattern)</i> • <i>file-size (Match Any File Over Size)</i> • <i>file-type-and-size (Match DLP File Pattern and File Size Over)</i> • <i>encrypted (Look for Encrypted files)</i> • <i>watermark (Look for Defined File Watermarks)</i> • <i>fingerprint (Match against fingerprint sensitivity)</i>
Regular Expression	Enter the pattern that network traffic is examined for. Note: The option is only available when <i>Match a Regular Expression</i> is set as the filter.
File Size	Enter the maximum file size in kilobytes (default = 10, 0 - 4294967295). Note: The option is only available when <i>Match Any File Over Size</i> or <i>Match DLP File Pattern and File Size Over</i> is set as the filter.
Company Identifier	Enter the company identifier. The company identifier is to make sure that you are only blocking watermarks that your company has placed on the files, not watermarks with the same name by other companies. Note: The option is only available when <i>Look for Defined File Watermarks</i> is set as the filter.
File Pattern	Select or create a DLP file pattern. <div style="text-align: center;">  <p>Use the pen icon next to the file pattern to edit it.</p> </div> Note: The option is only available when <i>Match a DLP File Pattern</i> or <i>Match DLP File Pattern and File Size Over</i> is set as the filter.
Protocols	Select one or more protocols that the filter will examine. This allows resources to be optimized by only examining relevant traffic. The available protocols are <i>HTTP-GET, HTTP-POST, and SSH.</i>



Filtering MAPI and SSH protocols only works in the proxy mode.



Use the search bar to look up a protocol.

Sensitivity

Select a sensitivity for the DLP filter rule: *Critical*, *Private*, and *Warning*.

Note: The option is only available when *Look for Defined File Watermarks* or *Match against fingerprint sensitivity* is selected as the filter.

Action

Select an action to take if the filter is triggered. Available actions are *Allow*, *Log Only*, and *Block*.

3. Click *OK*.



From the list, select a rule and then select *Edit* to edit the rule.

From the list, select rules and then select *Delete* to delete the rules.

DLP via the CLI - Example

To configure a file type and name filter:

1. In the CLI console, enter the following commands to create a file pattern to filter files based on the file name pattern or file type. In this example, we intend to filter for GIFs and PDFs:

```
config dlp filepattern
edit 11
set name "sample_config"
config entries
edit "*.gif"
set filter-type pattern
next
edit "pdf"
set filter-type type
set file-type pdf
next
end
next
end
```

2. Create the DLP sensor (**Note:** `http-get` and `http-post` protocols apply to *Web SFTP* and *Web SMB* launchers):

```
config dlp sensor
edit <name>
config filter
edit <id>
set name <string>
set proto {http-get http-post ssh}
set filter-by file-type
```

```

        set file-type 11
        set action {allow | log-only | block | quarantine-ip}
    next
end
next
end

```

To configure a file size filtering:

1. In the CLI console, use the following commands:

```

config dlp sensor
  edit <name>
    config filter
      edit <id>
        set name <string>
        set proto {http-get http-post ssh}
        set filter-by file-size
        set file-type 11
        set action {allow | log-only | block | quarantine-ip}
      next
    end
  next
end

```

To configure regular expression filtering:

1. In the CLI console, use the following commands:

```

config dlp sensor
  edit <name>
    config filter
      edit <id>
        set name <string>
        set type {file | message}
        set proto {http-get http-post ssh}
        set filter-by regexp
        set regexp <string>
        set action {allow | log-only | block | quarantine-ip}
      next
    end
  next
end

```

Supported file types

The following file types are supported in DLP profiles:

Type	Description
.net	Match .NET files
7z	Match 7-Zip files
activemime	Match ActiveMime files

Type	Description
arj	Match ARJ compressed files
aspack	Match ASPack files
avi	Match AVI files
base64	Match Base64 files
bat	Match Windows batch files
binhex	Match BinHex files
bmp	Match BMP files
bzip	Match Bzip files
bzip2	Match Bzip2 files
cab	Match Windows CAB files
chm	Match Windows compiled HTML help files
class	Match CLASS files
cod	Match COD files
crx	Match Chrome extension files
dmg	Match Apple disk image files
elf	Match ELF files
exe	Match Windows executable files
flac	Match FLAC files
fsg	Match FSG files
gif	Match GIF files
gzip	Match Gzip files
hlp	Match Windows help files
hta	Match HTA files
html	Match HTML files
iso	Match ISO archive files
jad	Match JAD files
javascript	Match JavaScript files
jpeg	Match JPEG files
lzh	Match LZH compressed files
mach-o	Match Mach object files

Type	Description
mime	Match MIME files
mov	Match MOV files
mp3	Match MP3 files
mpeg	Match MPEG files
msi	Match Windows Installer MSI Bzip files
msoffice	Match MS-Office files. For example, DOC, XLS, PPT, and so on.
msofficex	Match MS-Office XML files. For example, DOCX, XLSX, PPTX, and so on.
pdf	Match PDF files
petite	Match Petite files
png	Match PNG files
rar	Match RAR archives
rm	Match RM files
sis	Match SIS files
tar	Match TAR files
tiff	Match TIFF files
torrent	Match torrent files
unknown*	Match unknown files
upx	Match UPX files
uue	Match UUE files
wav	Match WAV files
wma	Match WMA files
xar	Match XAR archive files
xz	Match XZ files
zip	Match ZIP files

*This file type is only available in DLP profiles.

DLP file pattern

DLP file patterns match selected file types and file patterns. They are used as DLP filter rules in DLP sensors.

DLP File Pattern in *Secret Settings* displays a list of configured DLP file patterns.

For each DLP file pattern; ID, name, comments, and reference are shown.



The *Ref.* column displays the number of times the object is referenced to other objects. To view the location of the referenced object, select the number in *Ref.*; the *Object Usage* window opens and displays the various locations of the referenced object.

ID	Name	Comments	Ref.
1	builtin-patterns		0
2	all_executables		0

The *DLP File Pattern* tab contains the following options:

Create New	Create a DLP file pattern. See Creating a DLP file pattern on page 203 .
Edit	Select to edit the selected DLP file pattern.
Delete	Select to delete the selected DLP file patterns.

Creating a DLP file pattern

To create a DLP file pattern:

1. Go to *Secret Settings > DLP File Pattern*.
2. From the DLP file pattern list, select *Create New*.

The *Create DLP File Pattern* window opens.

Create DLP File Pattern

ID

Name

Comments

File Type

<input type="checkbox"/> 7Z	<input type="checkbox"/> ARJ	<input type="checkbox"/> CAB	<input type="checkbox"/> LZH
<input type="checkbox"/> RAR	<input type="checkbox"/> TAR	<input type="checkbox"/> GZIP	<input type="checkbox"/> BZIP2
<input type="checkbox"/> XZ	<input type="checkbox"/> BAT	<input type="checkbox"/> UUE	<input type="checkbox"/> MIME
<input type="checkbox"/> BASE64	<input type="checkbox"/> BINHEX	<input type="checkbox"/> ELF	<input type="checkbox"/> EXE
<input type="checkbox"/> HTA	<input type="checkbox"/> HTML	<input type="checkbox"/> JAD	<input type="checkbox"/> CLASS
<input type="checkbox"/> COD	<input type="checkbox"/> JAVASCRIPT	<input type="checkbox"/> MSOFFICE	<input type="checkbox"/> MSOFFICEEX
<input type="checkbox"/> FSG	<input type="checkbox"/> UPX	<input type="checkbox"/> PETITE	<input type="checkbox"/> ASPACK
<input type="checkbox"/> SIS	<input type="checkbox"/> HLP	<input type="checkbox"/> ACTIVEMIME	<input type="checkbox"/> JPEG
<input type="checkbox"/> GIF	<input type="checkbox"/> TIFF	<input type="checkbox"/> PNG	<input type="checkbox"/> BMP
<input type="checkbox"/> UNKNOWN	<input type="checkbox"/> MPEG	<input type="checkbox"/> MOV	<input type="checkbox"/> MP3
<input type="checkbox"/> WMA	<input type="checkbox"/> WAV	<input type="checkbox"/> PDF	<input type="checkbox"/> AVI
<input type="checkbox"/> RM	<input type="checkbox"/> TORRENT	<input type="checkbox"/> MSI	<input type="checkbox"/> MACH-O
<input type="checkbox"/> DMG	<input type="checkbox"/> .NET	<input type="checkbox"/> XAR	<input type="checkbox"/> CHM
<input type="checkbox"/> ISO	<input type="checkbox"/> CRX	<input type="checkbox"/> FLAC	<input type="checkbox"/> ZIP

File Pattern

3. Enter the following information:

ID	Identifier for the DLP file pattern.
Name	The name of the DLP file pattern.
Comments	Optionally, enter a description for the DLP file pattern.
File Type	Select one or more file types. <hr/>  To select all the file types, click <i>Select All</i> . To unselect all the file types, click <i>Unselect All</i> . <hr/>
File Pattern	Enter one or more file patterns.

4. Click *OK*.

SSH filter profiles

SSH Filter Profiles tab in *Secret Settings* displays a list of SSH filter profiles.

A filter can be created to prevent certain commands from running on an SSH terminal.

For each SSH profile; name, block, log, default command log, extra shell commands, and reference are displayed.

The *SSH Filter Profiles* tab contains the following options:

Create	Select to create a new SSH filter profile. See Creating an SSH filter on page 204 .
Edit	Select to edit the selected SSH filter profile.
Delete	Select to delete the selected SSH filter profiles.
Search	Enter a search term in the search field, then hit <code>Enter</code> to search the SSH filter profiles list. To narrow down your search, see Column filter .

Creating an SSH filter

To create an SSH filter profile:

1. Go to *Secret Settings* > *SSH Filter Profiles*.
2. In *SSH Filter Profiles*, select *Create*.
The *New SSH Filter Profile* window opens.

New SSH Filter Profile

Name

Shell Channel Other Channels



Shell Commands

ID	Type	Pattern	Action	Log	Alert	Severity
No results						

Default Command Log Disable Enable

Submit Cancel

3. Enter the following information:

Name	Name of the SSH filter.
Shell Commands	Shell commands can be created to block a command in the SSH terminal. See Creating Shell Commands .
	Select a shell command from the list and then select <i>Edit</i> to edit the command. When editing a shell command the options are same as when creating one.
	Select shell commands from the list then select <i>Delete</i> to delete the commands.
Default Command Log	Enable/disable logging unmatched shell commands. Note: The option is disabled by default
Other Channels	
Use this tab for advanced settings. Note: Settings in the tab require setting up a custom launcher.	
Block Channel	Select from the SSH blocking options (multiple options may be selected): <ul style="list-style-type: none"> • <i>X11</i>: X server forwarding • <i>SSH execution</i> • <i>Port forwarding</i> • <i>Tunnel forwarding</i> • <i>SFTP</i> • <i>SCP</i> • <i>Unknown channel</i>: Unknown channel (any channel other than the six listed here and the shell channel.)
Log Activity	SSH logging options. These are log activities related to selected channels regardless of the blocking status (multiple options may be selected): <ul style="list-style-type: none"> • <i>X11</i>: X server forwarding • <i>SSH execution</i> • <i>Port forwarding</i>

- *Tunnel forwarding*
- *SFTP*
- *SCP*
- *Unknown channel*

4. Click *Submit*.

To create a shell command:

1. In the *New SSH Filter Profile* window, select *Create* in the *Shell Commands* pane.

New Shell Command

Type Regex Simple

Pattern

Action Allow Block

Log Disable Enable

Alert Disable Enable

No pattern is blocked. No logs or alerts will be triggered.

OK Cancel

- In the *New Shell Command* window, enter the following information:

Type	Select the matching type: <ul style="list-style-type: none"> <i>Regex</i>: Match command line using regular expression. Choosing the option blocks any command matching <i>Regex</i> in <i>Pattern</i>. <i>Simple</i>: Match single command (default). Choosing the option matches any command fitting the one in <i>Pattern</i>.
Pattern	SSH shell command pattern. For example: <ul style="list-style-type: none"> When the <i>Type</i> is <i>Regex</i>, pattern <code>.*</code> stands for all the commands and pattern <code>sh.*</code> stands for all the commands beginning with <code>sh</code> including <code>show</code> and <code>shutdown</code>. When the <i>Type</i> is <i>Simple</i>, pattern <code>rm</code> stands for the <code>rm</code> command on Linux, e.g., <code>'rm -rf /*'</code>, <code>'rm test.py'</code>.
Action	Action to take for URL filter matches: <ul style="list-style-type: none"> <i>Allow</i>: Allow the SSH shell command on the target server. <i>Block</i>: Block the SSH shell command on the target server (default). For example when the <i>Type</i> is <i>Regex</i> , the <i>Pattern</i> is <code>conf.*</code> , and the <i>Action</i> is <i>Block</i> . This blocks all the configuration actions on the target server.
Log	Enable/disable logging. When enabled, the action logs are available in <i>Log & Report > SSH</i> .
Alert	Enable/disable alert. When enabled, the alert message is sent based on the configurations in <i>Log & Report > Email Alert Settings</i> .
Severity	The severity of the actions reported in <i>Log & Report > SSH</i> and alert messages: <ul style="list-style-type: none"> <i>Critical</i> <i>High</i> <i>Medium</i> <i>Low</i> (default) Note: The option is only available when <i>Log</i> is enabled.

- Click *OK*.

Adding SSH filter to secret

To add SSH filter to a secret:

- Go to *Secrets > Secret List*.
- In the *Secrets List*, double-click a secret to open.
Alternatively, in *Secrets > Personal Folder/Private Folder*, go to the folder where the secret is located, and double-click the secret to open.



If the secret does not show up, it may be because you do not have the necessary permission to access the secret or the folder where the secret is located.

3. In *Service Setting* tab, ensure that *SSH Service* is enabled.
4. Enable *SSH Filter* and then select an SSH filter profile from the *SSH Filter Profile* dropdown.
5. Click *Save*.

Example SSH filter profiles - example

To configure an SSH filter profile that only allows `show` command on the target server (FortiGate or Cisco routers):

1. Go to *Secret Settings > SSH Filter Profiles*.
2. In *SSH Filter Profiles*, select *Create*.
The *New SSH Filter Profile* window opens.
3. Enter a name for the SSH filter profile. In this example, the SSH filter profile is named `show only`.
4. In *Shell Commands*, select *Create*:
 - a. In *Type*, select *Regex*.
 - b. In *Pattern*, enter `show.*`.
 - c. In *Action*, select *Allow*.
 - d. In *Log*, select *Enable*.
 - e. In *Alert*, select *Disable*.
 - f. In *Severity*, select *Low*.
 - g. Click *OK*.
5. In *Shell Commands*, select *Create* again:
 - a. In *Type*, select *Regex*.
 - b. In *Pattern*, enter `.*`.
 - c. In *Action*, select *Block*.
 - d. In *Log*, select *Enable*.
 - e. In *Alert*, select *Enable*.
 - f. In *Severity*, select *Medium*.
 - g. Click *OK*.
6. Enable *Default Command Log*.
7. Click *Submit*.

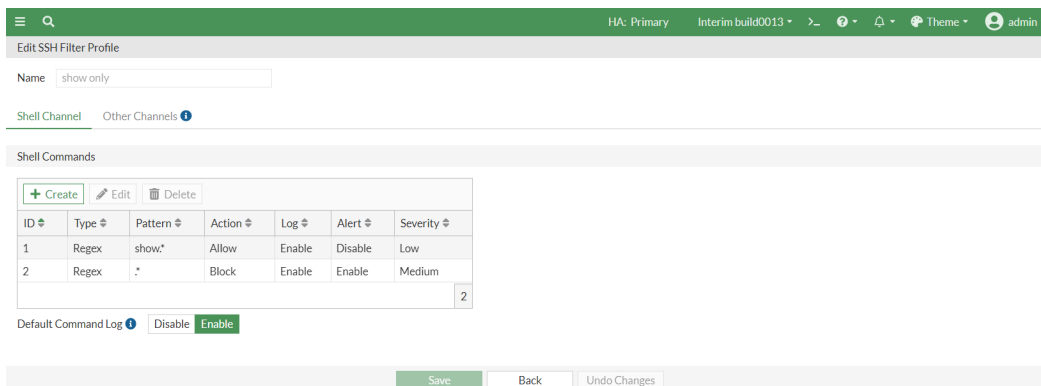

To configure an SSH filter profile that blocks `rm` and `sudo` commands on the target Linux server:

1. Go to *Secret Settings > SSH Filter Profiles*.
2. In *SSH Filter Profiles*, select *Create*.
The *New SSH Filter Profile* window opens.
3. Enter a name for the SSH filter profile. In this example, the SSH filter profile is named `block rm+sudo`.
4. In *Shell Commands*, select *Create*:
 - a. In *Type*, select *Simple*.
 - b. In *Pattern*, enter `rm`.
 - c. In *Action*, select *Block*.
 - d. In *Log*, select *Enable*.
 - e. In *Alert*, select *Enable*.
 - f. In *Severity*, select *Critical*.
 - g. Click *OK*.
5. In *Shell Commands*, select *Create* again:
 - a. In *Type*, select *Simple*.
 - b. In *Pattern*, enter `sudo`.
 - c. In *Action*, select *Block*.
 - d. In *Log*, select *Enable*.
 - e. In *Alert*, select *Enable*.
 - f. In *Severity*, select *Critical*.
 - g. Click *OK*.
6. Enable *Default Command Log*.
7. Click *Submit*.

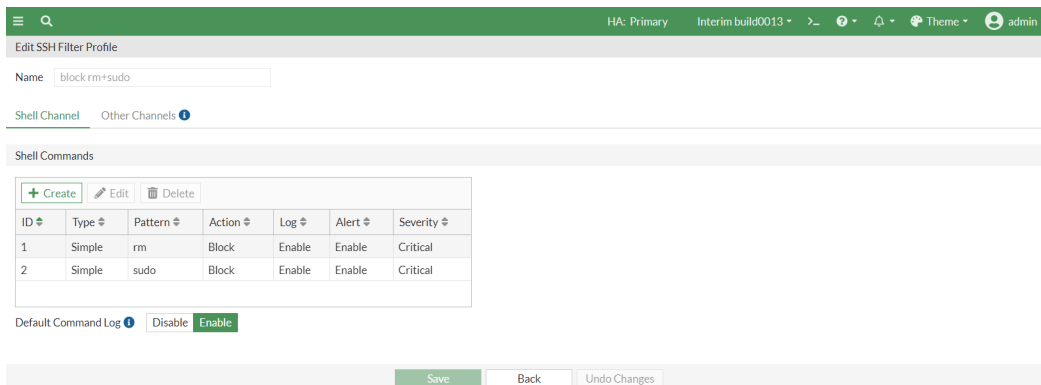

Event filter profile

The *Event Filter Profile* tab in *Secret Settings* displays a list of event filter profiles.

Using event filter profiles, FortiPAM can retrieve specific logs for events that occurred during an RDP session from a target.



The feature is agentless and relies on FortiPAM configuration, the WinRM service status, and the window audit policy on the target remote machine.

For each event filter profile; name, process log, file system log, user management event log, and references are displayed.

+	Create	🔍 Search					
<input type="checkbox"/>	Name	Process Log	Filesystem Log	User Management Event Log	References		
<input type="checkbox"/>	default_app_log	Skip	Skip	Skip	0		



A default *default_app_log* event filter profile is available.

The *Event Filter Profile* tab contains the following options:

Create	Select to create a new event filter profile. See Creating an event filter profile on page 210 .
Edit	Select to edit the selected event filter profile.
Delete	Select to delete the selected event filter profiles.
Search	Enter a search term in the search field, then hit <code>Enter</code> to search the event filter profiles list. To narrow down your search, see Column filter .

Creating an event filter profile

A secret event filter profile defines event categories pulled from the remote Windows server. Currently, users can monitor the following categories:

- Process related events, such as starting an application or terminating an existing application
- File system related events such as creating, accessing, and deleting a file
- User management related events such as creating a user.

Setting up an event filter profile requires that the server has enabled WinRM service and related audit policies, see [Appendix L: WinRM configuration for Windows server on page 465](#).

To create an event filter profile:

1. Go to *Secret Settings > Event Filter Profile*.
2. In *Event Filter Profile*, select *Create*.
The *New Event filter profile* window opens.

3. Enter the following information:

Name	Name of the event filter profile.
Process Log	Monitor/skip the process log (default = <i>Monitor</i>).
Filesystem Log	Monitor/skip the file system event log (default = <i>Monitor</i>).
User Management Log	Monitor/skip the user management event log (default = <i>Monitor</i>).

4. Click *Submit*.**Event filter profile via the CLI** - Example

1. In the CLI console, use the following commands to configure the event filter profile:

```
config secret event-filter-profile
edit "default_app_log"
set process-log {enable | disable} #Enable/disable pulling activity log
set filesystem-log {enable | disable} #Enable/disable pulling activity log
set user-management {enable | disable} #Enable/disable pulling activity log
next
end
```

2. In the CLI console, use the following commands to enable or disable the event filter for the policy or secret.

```
config secret policy
edit default
set event-filter {not-set | disable | enable}
set event-filter-profile "default_app_log"
end
end
config secret database
edit sec_1
set event-filter {not-set | disable | enable}
set event-filter-profile "default_app_log"
end
end
```

3. The launched secret requires a target with a privileged account with WinRM (Windows remote management) privilege.

Enable or disable `winrm-https` in the secret target using the following CLI commands:

```
config secret target
edit "3-84-141-197"
set class "Other"
set template "Windows Domain Account"
set address "ec2-3-84-141-197.compute-1.amazonaws.com"
set creation-time 2023-10-12 11:28:57
set winrm-https {enable | disable} #Enable
set access customized
config user-permission
edit 1
set user-name "admin"
set permission owner
next
```

```

end
set web-proxy-status disable
next
end

```

For information on WinRM configuration for Windows server, see [Appendix L: WinRM configuration for Windows server on page 465](#).

Limitations

The RDP log retrieving feature currently only works on RDP sessions proxied by FortiPAM with video recording enabled.

Integrity check

For every launcher, you can configure a client software entry in the *Integrity Check* tab in *Secret Settings* to enable integrity checks.



Client software integrity check requires FortiPAM 1.1 and FortiClient 7.2.2.

When the integrity check fails, the launching stops and a prompt appears showing where to download a version of the client software based on your FortiPAM configurations.



Using integrity check prevents launching of corrupt executables.

The following two types of integrity checks are available:

- *Executable hash*: Comparing the executable hash with the provided value.
- *Certificate*: Checking the certificate of a file.

An integrity check is considered passed when at least one version of the client software package is matched.

For each integrity check; name, number of pages, and references are displayed.

The *Integrity Check* tab contains the following options:

Create	Select to create a client software entry for integrity check. See Creating a client software entry for integrity check on page 213 .
Edit	Select to edit the selected client software entry.
Delete	Select to delete the selected client software entries.
Search	Enter a search term in the search field, then hit <code>Enter</code> to search the client software entry list. To narrow down your search, see Column filter .

Creating a client software entry for integrity check

To create a client software entry for integrity check:

1. Go to *Secret Settings > Integrity Check* and select *Create*. The *New Client Software* window opens.

2. Enter the following information:

Name The name of the client software entry.

Package Configure client software packages. See [Creating client software packages on page 213](#).



While creating a client software entry for integrity check, you can either store the software package locally, i.e., on the FortiPAM disk or provide an external URL to the package for downloading.



3. Click *Submit*.

Creating client software packages

To create a client software package

1. In Step 1, when [Creating a client software entry](#), select *Create* in the *Package* pane. The *New Client Package* window opens.

2. Enter the following information:

Name	The name of the client software package.
Integrity Check Option	<p>Select from the following integrity check options:</p> <ul style="list-style-type: none"> • <i>Executable hash</i>: Comparing the executable hash with the provided value (default). • <i>Certificate</i>: Checking the certificate of a file.
Hash Algorithm	<p>Select from the following hash algorithms:</p> <ul style="list-style-type: none"> • <i>MD5</i> (default) • <i>SHA-1</i> • <i>SHA-256</i> <p>Note: The option is only available when the <i>Integrity Check Option</i> is <i>Executable hash</i>.</p>
Hash	<p>The package/folder hexadecimal hash value.</p> <p>Note: The option is only available when the <i>Integrity Check Option</i> is <i>Executable hash</i>.</p>
CA Certificate	<p>From the dropdown, select a CA certificate.</p> <hr/> <div style="display: flex; align-items: center;">  <p>Use the search bar to look up a CA certificate.</p> </div> <hr/> <p>Note: The option is only available when <i>Integrity Check Option</i> is <i>Certificate</i>.</p>
Package Download Option	<p>Select from the following two options:</p> <ul style="list-style-type: none"> • <i>Internal download URL</i> • <i>External download URL</i> (default)
External Download Url	<p>The external download URL for the client software package.</p> <hr/> <div style="display: flex; align-items: center;">  <p>Only installers are supported.</p> </div> <hr/> <p>Note: The option is only available when the <i>Package Download Option</i> is <i>External download URL</i>.</p>
Package	<p>Select + <i>Upload File</i>, locate the client software package from your management computer, and click <i>Open</i>.</p> <p>Note: The option is only available when the <i>Package Download Option</i> is <i>Internal download URL</i>.</p>

3. Click OK.

	<p>From the list, select a client software package and then select <i>Edit</i> to edit the packages.</p> <p>From the list, select client software packages and then select <i>Delete</i> to delete the packages.</p>
---	--

Creating a client software entry for integrity check via the CLI - Example

1. In the CLI console, enter the following commands to configure the client software table. In the example, for the PuTTY launcher, we have two client software packages. x64 checks the file certificate and downloads the package from an external link. x86 checks against the MD5 checksum and stores the package locally.

```
config secret client-software
  edit "putty"
    config pkg
      edit "x64"
        set integrity-check cert
        set download-option external
        set external-url
          "https://the.earth.li/~sgtatham/putty/latest/w64/putty.exe"
        set ca "Fortinet_SSL"
        set client-name "putty"
      next
      edit "x86"
        set hash-algo MD5
        set hash "aeb47b393079d8c92169f1ef88dd5696"
        set package-name "putty.exe"
        set client-name "putty"
      next
    end
  next
end
```

2. Enter the following commands to go to the secret launcher table and bind the client software entry with the launcher.

```
config secret launcher
  edit "PuTTY"
    set type ssh
    set client-software "putty"
  next
end
```

3. Enter the following commands to enable the integrity check option in the launcher settings of the template.

```
config secret template
  edit "Unix Account (SSH Password)"
    config launcher
      edit 2
        set launcher-name "PuTTY"
        set port 22
        set integrity-check enable
      next
    end
  next
end
```

With the configurations set as above, the secret with *Unix Account (SSH Password)* template and *PuTTY* as the launcher includes an integrity check each time it is launched.

User management

In *User Management*, you can access the following tabs:

- [User list on page 216](#)
- [User groups on page 234](#)
- [Sponsored groups on page 240](#)
- [Role on page 243](#)
- [LDAP servers on page 255](#)
- [SAML Single Sign-On \(SSO\) on page 258](#)
- [RADIUS servers on page 265](#)
- [Auto provision rules on page 261](#)
- [Schedule on page 267](#)
- [FortiTokens on page 270](#)

User list

User List in *User Management* displays a list of FortiPAM users listed by their role types.

For each user, the following columns are displayed:

- *Name*
- *Sponsored Group*
- *Role*
- *Type*
- *Latest Login*
- *Status*
- *Two-factor Authentication*
- *References*
- *Created By*



By default, FortiPAM only lists enabled users.



Enable *Show all users* to list all the users.

+ Create		+ Import		🔍 Search		+ Show Disabled Users		+ Section By Sponsored Group	
Name	Role	Type	Lastest Login	Status	Created By	Provision Rule			
ldap_6	Standard User	Remote	2024-01-08 10:51:43	Enable	Auto Provision	Out of Sync			
ldap_7	Standard User	Remote	2024-01-05 13:58:22	Enable	Auto Provision	Out of Sync			
ldap_8	Standard User	Remote		Enable	Auto Provision	Out of Sync			
ldap_9	Standard User	Remote	2024-01-08 11:11:55	Enable	Auto Provision	Out of Sync			
ldap_12	Standard User	Remote	2024-01-08 11:15:57	Enable	Manual Creation				
ldap_14	Standard User	Remote	2024-01-08 11:21:55	Enable	Manual Creation				
ldap_15	Standard User	Remote	2024-01-08 11:24:44	Enable	Manual Creation				
ldap_16	Standard User	Remote	2024-01-08 11:35:07	Enable	Manual Creation				
ldap_18	Standard User	Remote	2024-01-08 11:50:13	Enable	Auto Provision	Out of Sync			
ldap_19	Standard User	Remote	2024-01-08 11:51:36	Enable	Auto Provision	Out of Sync			
ldap_21	Standard User	Remote	2024-02-28 14:09:54	Enable	Auto Provision	ldap_grp2_std			
ldap_24	Standard User	Remote	2024-01-11 12:02:29	Enable	Auto Provision	Out of Sync			
ldap_25	Standard User	Remote	2024-01-11 12:08:27	Enable	Auto Provision	Out of Sync			
m1	Standard User	Local		Enable	Manual Creation				
m2	Standard User	Local		Enable	Manual Creation				
m3	Standard User	Local		Enable	Manual Creation				
pam15_rad2	Standard User	Remote	2024-02-28 14:12:27	Enable	Auto Provision	radius_grp1			
role_audit	Standard User	Local		Enable	Manual Creation				

27 used / 50 licensed

CLI Console (1)

The user list contains the following options:

Create	Select to create a new user. See Creating a user on page 218 .
Import	Select to import remote LDAP users from an LDAP server. See Importing LDAP users on page 231 .
Edit	Select to edit the selected user account.
Disable	Select to disable the selected user account or accounts.
Delete	Select to delete the selected user account or accounts. See Deleting a user .
Search	Enter a search term in the search field, then hit <code>Enter</code> to search the user list. To narrow down your search, see Column filter .
Show/Hide Disabled Users	Select to show or hide disabled users.
Section By Sponsored Group/Default	Select to section the user list by sponsored groups or by default sections.



On the bottom-left, the number of used license seats and the total number of allowed license seats are displayed as a label. This label is green when seats are available. The label turns red when all the seats have been used up. Once the seats are used up, new users cannot be enabled without disabling enabled users.



Out-of-sync users do not occupy license seats.

To enable/disable a user:

1. Right-click a user from the user list and then select *Enable/Disable* from *Set status*.
2. To refresh the user list, select *Reload Now* from the message that appears on the bottom-right.

▲ Entries have changed since last load. [Reload Now](#) ✕

To delete a user:

1. Right-click a user from the user list and then select *Delete*.
A user that does not solely own any public resource is deleted.
2. If the deleted user owns public resources, e.g., secrets, user groups, or folders, a delegation window appears.

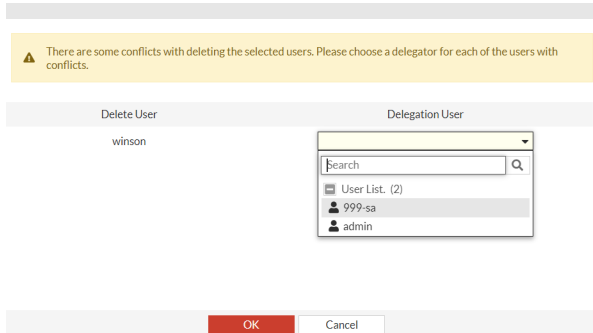

3. In the delegation window, from the *Delegation User* dropdown, select a user who will own the resources once the user owning the resource is deleted.
4. Click *OK*.



The deleted user's personal folder, personal subfolders, secrets, requests, and jobs are all removed on deletion.



Only public resources are delegated to the user selected in *Delegation User*.



Another user must be given ownership of a secret, template, target, or group, if the deleted user is the only owner for the resource (or the only member in a group).



Another user must be given ownership of the folder, if the deleted user is the only owner of the folder and secrets within the folder.



Approved and currently running secret jobs must be delegated to another user when the owner is deleted.

Creating a user



By default, FortiPAM has a default user with the username `admin` and no password. When you go into the system for the first time, you must set a password for this account. Additional users can be added later.

To create a user:

1. Go to *User Management > User List*, and select *Create*. The *New User List* wizard is launched.

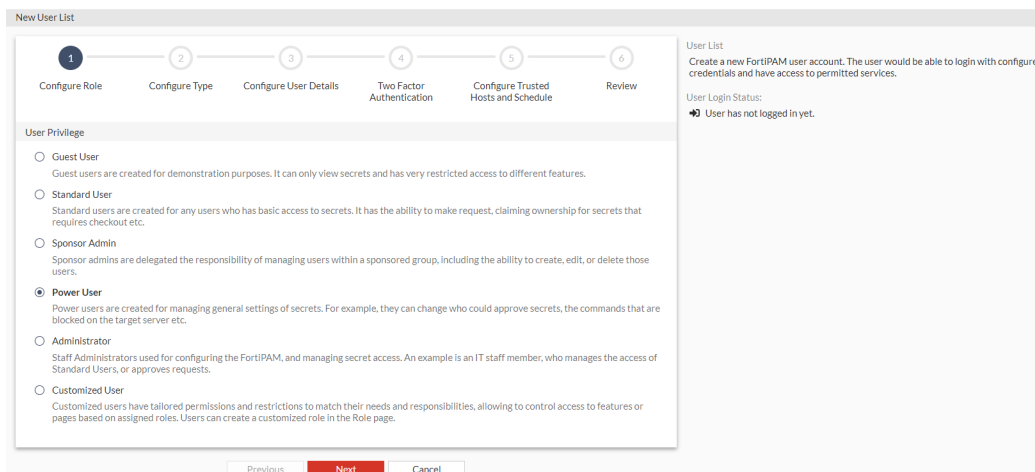

2. Enter the following information, and click *Next* after each tab:

Configure Role

User Privilege

Select from the following user role types:

- *Guest User*
- *Standard User*
- *Sponsor Admin*
- *Power User*
- *Administrator*
- *Customized User*

For *Sponsor Admin*, select a sponsor admin role and a sponsored group. Sponsor admins can only manage users within their assigned sponsored group. For more information about sponsored groups, see [Sponsored groups on page 240](#).

For *Administrator*, select from one of the available administrator roles from the *Choose an Administrator Role* dropdown.

For *Customized User*, select from one of the available custom roles from the *Choose a custom defined Role* dropdown.

The sponsor admin/administrator/custom role decides what a sponsor admin, administrator, or customized user can see. Depending on the nature of the administrator work, access level, or seniority, you can allow them to view and configure as much or as little as required.

Use the search bar to look for an administrator/custom role.

For information on the user types and their roles, see [Users in FortiPAM on page 223](#) and [Role on page 243](#).

Configure Type

User Type

Select a user type:

- *Local User*



To change the local user password, see [Admin on page 21](#).

- *API User*
- *Remote User*: Select the option if you want to enable login for one remote user in a remote group, and assign the user the remote user type for the FortiPAM session.

For *Remote User*, select a remote group where the user is found from the *Choose a Remote Group where these users can be found or a Remote Server* dropdown. See [User groups on page 234](#).



Use the search bar to look for a remote group.



For information on the user types, see [Users in FortiPAM on page 223](#).

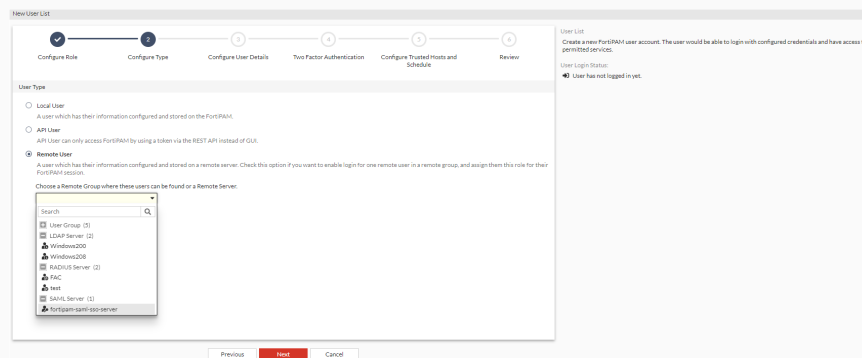

Or

For *Remote User*, select a remote server where the user resides from the *Choose a Remote Group where these users can be found or a Remote Server* dropdown. See [LDAP servers on page 255](#), [SAML Single Sign-On \(SSO\) on page 258](#), and [RADIUS servers on page 265](#).



Use the search bar to look for a remote server.

	 <p>In the <i>Choose a Remote Group where these users can be found</i> or a <i>Remote Server</i> dropdown, remote user groups and remote servers are mutually exclusive, i.e., only one can be selected.</p>
Force SAML Login	<p>Enable/disable forced SAML login (default = disable). Note: This option must be enabled when creating a SAML user.</p>
Configure User Details	
Username	<p>The username.</p> <hr/>  <p>Do not use < > () # " ' ` characters in the username.</p>
Password	<p>The password. Note: This option is only available when the user type is local.</p>
Confirm Password	<p>Enter the password again to confirm. Note: This option is only available when the user type is local.</p>
Status	<p>Enable/disable user login to FortiPAM.</p> <hr/>  <p>When you attempt to create a new user that exceeds the licensed seats, the <i>Status</i> option in the <i>Configure User Details</i> tab cannot be enabled. As you hover over the <i>Enable</i> button, a tooltip appears, alerting you that the user cannot be enabled as you have exceeded your license seat.</p> <hr/> <p>Note: The option is not available when the user type is an API user.</p>
Comments	<p>Optionally, enter comments about the user.</p>
Two Factor Authentication	
Email address	<p>The email address. Note: This option is mandatory for all authentication types.</p>
Critical System Email Alert	<p>Enable/disable sending critical system alerts via email. Note: The option is disabled by default.</p>
General Email Alert	<p>Enable/disable sending general alerts via email. Note: The option is disabled by default.</p>
Two-Factor Authentication	<p>Enable/disable using two-factor authentication. Note: Two factor authentication is disabled by default. Note: Two factor authentication is not available for an API user. You can also set up <i>Two Factor Authentication</i> using CLI. See Two Factor Authentication using CLI.</p>

	<p>Specify the type of user authentication used:</p> <ul style="list-style-type: none"> • <i>FortiToken</i> • <i>FortiToken Cloud</i>. See 2FA with FortiToken Cloud example on page 224. • <i>Email</i> (default)
	<p> SMS based two factor authentication is not supported in FortiPAM 1.3.1.</p>
Token	<p>From the dropdown, select a token.</p> <p>Note: The option is mandatory and only available when the <i>Authentication Type</i> is <i>FortiToken</i>.</p>
Configure Trusted Hosts	
IPv4 Trusted Hosts	<p>Trusted IPv4 addresses users use to connect to FortiPAM.</p> <p> Use + button to add a new IPv4 address and x to delete an added IPv4 address.</p>
Configure the schedule for which the user can connect to the FortiPAM	<p>Enable/disable configuring the login schedule for the users.</p> <p>From the dropdown, select a schedule. See Schedule on page 267.</p> <p>Note: This option is disabled by default.</p>

3. In the *Review* tab, verify the information you entered and click *Submit* to create the user.



Use the pen icon to edit tabs.



Alternatively, use the CLI commands to create users.

To regenerate the API key:

1. Go to *User Management > User List*.
2. Select the API user whose API key you intend to change and then select *Edit*.
3. In the *Details* pane, select *Re-generate API Key*.
4. In the *Re-generate API Key* window, select *Generate*.



Regenerating the API key will immediately revoke access for any API consumers using the current key.

A new API key for the API user is generated.

5. Click *Close*.

CLI configuration to set up a local user - example:

```
config system admin
  edit <user_name>
    set accprofile <role_name>
    set password <password>
  next
end
```

CLI configuration to set up a remote LDAP user - example:

```
config system admin
  edit <ldap_username>
    set remote-auth enable
    set accprofile <profname>
    set remote-group <ldap_group_name>
  next
end
```

CLI configuration to set up a remote RADIUS user - example:

```
config system admin
  edit <radius_username>
    set remote-auth enable
    set accprofile <profname>
    set remote-group <radius_group_name>
  next
end
```

CLI configuration to enable two-factor authentication - example:

```
config system admin
  edit <username>
    set password "myPassword"
    set two-factor <fortitoken | fortitoken-cloud | email>
    set fortitoken <serial_number>
    set email-to "username@example.com"
  next
end
```

Users in FortiPAM

The following user types are available:

- *Local User*: Information configured and stored on the FortiPAM.
- *API User*: Accesses FortiPAM by using a token via REST API instead of the GUI.
- *Remote User*: Information configured and stored on a remote server.

FortiPAM users can have one of the following role types:

- *Guest User*: For demonstration purposes only. Guest users can only view secrets and have restricted access to FortiPAM features.

- **Standard User:** Logs in, makes requests for resources, and connect to the privileged resources.
The standard user role is for basic use only. A standard user is not allowed to configure or manage access to privileged resources, e.g., a user that connects to the workstation.
- **Sponsor Admin:** For managing users assigned to their sponsored group(s). This includes creating, editing, and deleting users assigned to their sponsored group(s). Sponsor admins can only access logs and reports for their specific users, groups, and secrets.



The *Sponsor Admin* user has *View Secret Log* and *View Secret Video* permissions by default.

For information on *View Secret Log* and *View Secret Video* permissions, see [Role on page 243](#).

- **Power User:** For managing general secret settings, e.g., a power user can change who approves secrets, commands blocked on the target server, etc.
- **Administrator:** Staff administrators used for configuring FortiPAM, and managing access to privileged resources, e.g., an IT staff member managing the access of standard users or approving requests.



For *Administrator*, administrator roles are available. See [Role on page 243](#).

- **Customized User:** Customized users have tailored permissions and restrictions to match their needs and responsibilities, allowing them to control access to features or pages based on assigned roles. You can create a customized role in [Role](#).
See [Creating a user on page 218](#).

2FA with FortiToken Cloud - example

To configure a user with FortiToken Cloud as the authentication type:

1. Go to *User Management > User List*, and select *Create*.
The *New User List* wizard is launched.
2. In *Configure Role*, select *Administrator*, and from the *Choose an Administrator Role* dropdown, select *Super Administrator*.

The screenshot shows the 'New User List' configuration wizard at step 1, 'Configure Role'. A progress bar at the top indicates six steps: 1. Configure Role (active), 2. Configure Type, 3. Configure User Details, 4. Two Factor Authentication, 5. Configure Trusted Hosts and Schedule, and 6. Review. Below the progress bar, the 'User Privilege' section contains several radio button options: 'Guest User', 'Standard User', 'Sponsor Admin', 'Power User', 'Administrator' (selected), and 'Customized User'. Each option has a brief description of its capabilities. Under 'Administrator', there is a dropdown menu for 'Choose an Administrator Role' with 'Super Administrator' selected. At the bottom, there are 'Previous', 'Next', and 'Cancel' buttons. On the right side, a 'User List' section contains instructions: 'Create a new FortiPAM user account. The user would be able to login with configured credentials and have access to permitted services.' Below this, the 'User Login Status' is shown as 'User has not logged in yet.'

3. Click *Next*.

4. In *Configure Type*, select either *Local User* or *Remote User*.
In this example, *Local User* is selected.

The screenshot shows the 'New User List' configuration wizard at step 2, 'Configure Type'. The progress bar now shows step 1 completed (with a checkmark) and step 2 active. The 'User Type' section contains three radio button options: 'Local User' (selected), 'API User', and 'Remote User'. Each option has a brief description. At the bottom, there are 'Previous', 'Next', and 'Cancel' buttons. The right side of the screen remains the same as in the previous screenshot, showing the 'User List' instructions and 'User Login Status'.



For *Remote User*, select a remote group where the user is found. See [User groups](#) on page 234.

5. Click *Next*.

6. In *Configure User Details*:

- a. In *Username*, enter a name.
- b. In *Password*, enter a password.
- c. In *Confirm Password*, reenter password to confirm.

d. In *Status*, enable logging in to FortiPAM.

7. Click *Next*.

8. In *Two Factor Authentication*:

- a. In *Email address*, enter the user email address where the activation code for FortiToken Cloud is sent.
- b. Enable *Two-Factor Authentication*, and select *FortiToken Cloud*.

c. Click *Next*.

9. Click *Next*.

10. In the *Review* tab, verify the information you entered and click *Submit* to create the user.

11. From the user dropdown on the top-right, select *Logout*.

12. On the login screen, enter the username and password for the user you just created, and select *Continue*.

13. On the token screen, enter the token from your FortiToken Mobile and select *Continue* to log in to FortiPAM, or approve the push login request that appears on your mobile phone to log in to FortiPAM.

CLI configuration to set up a user with FortiToken Cloud as the authentication type - example:

```
config system admin
  edit "token"
    set accprofile "super_admin" #administrator role
    set two-factor fortitoken-cloud
    set email-to "username@example.com"
    set password "myPassword"
  next
end
```

CLI configuration to set up an interface for FortiPAM - example:

```

config system interface
  edit "port1"
    set ip 192.168.1.99 255.255.255.0
    set type physical
    set snmp-index 1
  next
end

```

CLI configuration to set up a virtual IP address for FortiPAM - example:

```

config firewall vip
  edit "fortipam_vip"
    set uuid 858a44ac-f359-51ec-e7ec-717ef0afbf4d
    set type access-proxy
    set extip 192.168.1.109 #VIP and the interface IP address are different.
    set extintf "any"
    set server-type https
    set extport 443
    set ssl-certificate "Fortinet_SSL"
  next
end

```

2FA with FortiToken - example**To configure a user with FortiToken as the authentication type:**

1. Go to *User Management > User List*, and select *Create*.
The *New User List* wizard is launched.
2. In *Choose a User Role type*, select *Administrator*, and from the *Choose an Administrator Role* dropdown, select *Super Administrator*.

New User List

1 Configure Role 2 Configure Type 3 Configure User Details 4 Two Factor Authentication 5 Configure Trusted Hosts and Schedule 6 Review

User Privilege

- Guest User
Guest users are created for demonstration purposes. It can only view secrets and has very restricted access to different features.
- Standard User
Standard users are created for any users who has basic access to secrets. It has the ability to make request, claiming ownership for secrets that requires checkout etc.
- Sponsor Admin
Sponsor admins are delegated the responsibility of managing users within a sponsored group, including the ability to create, edit, or delete those users.
- Power User
Power users are created for managing general settings of secrets. For example, they can change who could approve secrets, the commands that are blocked on the target server etc.
- Administrator
Staff Administrators used for configuring the FortiPAM, and managing secret access. An example is an IT staff member, who manages the access of Standard Users, or approves requests.
Choose an Administrator Role:
 Super Administrator
- Customized User
Customized users have tailored permissions and restrictions to match their needs and responsibilities, allowing to control access to features or pages based on assigned roles. Users can create a customized role in the Role page.

User List
Create a new FortiPAM user account. The user would be able to login with configured credentials and have access to permitted services.

User Login Status:
➔ User has not logged in yet.

Previous Next Cancel

3. Click *Next*.

4. In *Choose a User type*, select either *Local User* or *Remote User*. In this example, *Local User* is selected.

New User List

Configure Role **2** Configure Type 3 Configure User Details 4 Two Factor Authentication 5 Configure Trusted Hosts and Schedule 6 Review

User List
Create a new FortiPAM user account. The user would be able to login with configured credentials and have access to permitted services.

User Login Status:
➔ User has not logged in yet.

User Type

- Local User**
A user which has their information configured and stored on the FortiPAM.
- API User
API User can only access FortiPAM by using a token via the REST API instead of GUI.
- Remote User
A user which has their information configured and stored on a remote server. Check this option if you want to enable login for one remote user in a remote group, and assign them this role for their FortiPAM session.

Previous **Next** Cancel



For *Remote User*, select a remote group where the user is found. See [User groups on page 234](#).

5. Click *Next*.
6. In *Configure User Detail*:
 - a. In *Username*, enter a name.
 - b. In *Password*, enter a password.
 - c. In *Confirm Password*, reenter password to confirm.
 - d. In *Status*, enable logging in to FortiPAM.
 - e. In *Email address*, enter an email address.

New User List

Configure Role 2 Configure Type **3** Configure User Details 4 Two Factor Authentication 5 Configure Trusted Hosts and Schedule 6 Review

User List
Create a new FortiPAM user account. The user would be able to login with configured credentials and have access to permitted services.

User Login Status:
➔ User has not logged in yet.

User Details

Username: token

Password: [masked]

Confirm Password: [masked]

Status: Enable

Comments: Write a comment...

Previous **Next** Cancel

7. Click *Next*.
8. In *Two Factor Authentication*:
 - a. In *Email address*, enter the user email address.
 - b. Enable *Two-Factor Authentication*, and select *FortiToken*.

- c. From the *Token* dropdown, select a FortiToken.

- d. Click *Next*.

9. Click *Next*.

10. In the *Review* tab, verify the information you entered and click *Submit* to create the user.

11. Go to *User Management > FortiTokens*, select the token used in step 8 from the list and then click *Provision*. An email notification is sent to the user. This is the email address configured in step 8.

12. To enable FortiToken push notification:

- Go to *Network > Interfaces* and double-click port1.
- In *Administrative Access*, select *FTM*.
- In the CLI console, enter the following commands:

```
config system ftm-push
  set server-cert "Fortinet_Factory"
  set server x.x.x.x #IP address of the FortiPAM interface
  set status enable
end
```

13. From the user dropdown on the top-right, select *Logout*.

14. On the login screen, enter the username and password for the user you just created, and select *Continue*.

15. On the token screen, enter the token from your FortiToken Mobile and select *Continue* to log in to FortiPAM, or approve the push login request that appears on your mobile phone to log in to FortiPAM. See [Setting up FortiToken Mobile on page 230](#).

CLI configuration to set up a user with FortiToken as the authentication type - example:

```
config system admin
  edit "token"
    set accprofile "super_admin" #administrator role
    set two-factor fortitoken
    set fortitoken "FTKMOB29B10062D4"
    set email-to "username@example.com"
    set password "myPassword"
  next
end
```

Setting up FortiToken Mobile

To set up FortiToken Mobile:

1. In the App Store, look for FortiToken Mobile and install the application.

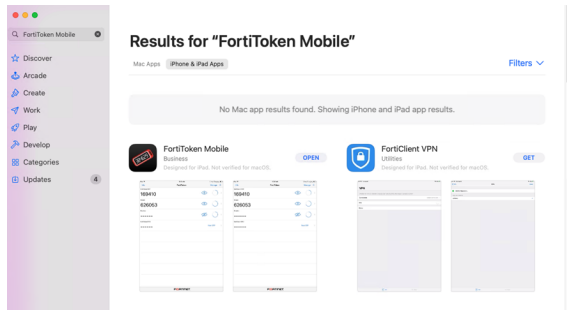

2. After your system administrator assigns a token to you, you will receive a notification with an activation code and an activation expiration date by which you must activate your token. For more information on *Token Activation*, see [FortiToken Mobile User Guide](#).

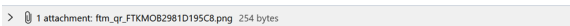
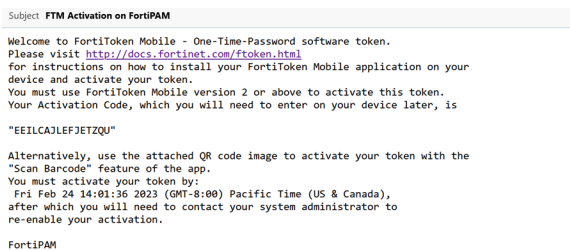

3. Open the FortiToken Mobile application and click + icon on the top-right to add a token.

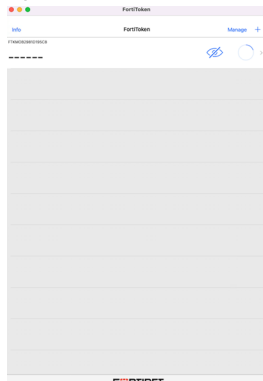

4. There are two ways to add a token to the FortiToken Mobile application:
 - a. **Scan QR code:** If your device supports QR code recognition, select + in the FortiToken Mobile home screen and point your device camera at the QR code attached to the activation email.



b. Enter Manually:

- i. Select + and then select *Enter Manually* from the bottom.
- ii. Select *Fortinet* and enter *Name* and *Key*.



Key is the activation key from your activation email notification and must be entered exactly as it appears in the activation message, either by typing or copying and pasting.

iii. Click Done.

FortiToken Mobile communicates with the secure provisioning server to activate your token. The token is now displayed in the token list view.



5. Click the eye icon to retrieve the token to be used in step 15 when configuring 2FA with FortiToken.

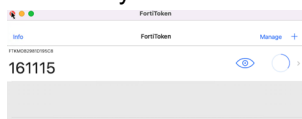

Alternatively, if approving the push login request in step 15 when configuring 2FA with FortiToken, click *Approve* in *Login Request*.

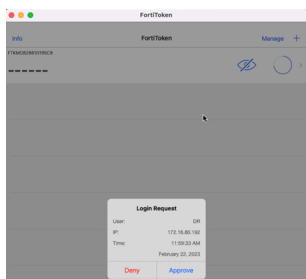

Importing LDAP users

To import LDAP users:

- 1. Go to *User Management > User List*, and select *Import*. The *New User List* wizard is launched.

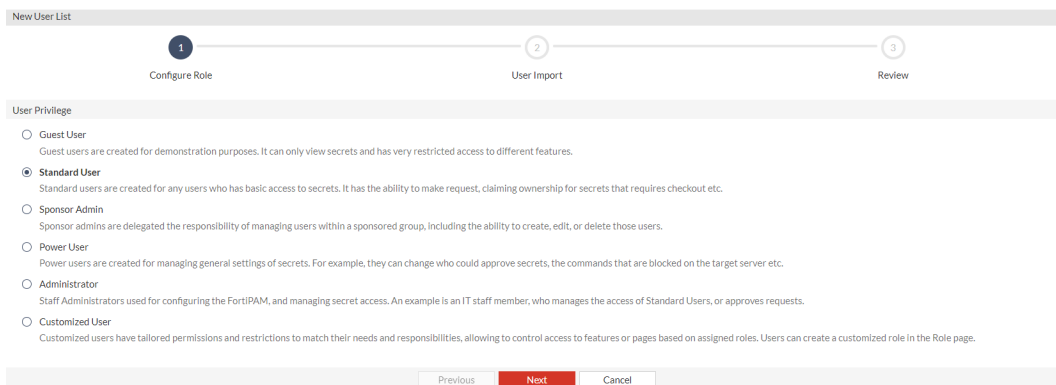

2. Enter the following information, and click *Next* after each tab:

Configure Role

User Privilege

Select from the following user role type:

- *Guest User*
- *Standard User*
- *Sponsor Admin*
- *Power User*
- *Administrator*
- *Customized User*

For *Sponsor Admin*, select a sponsor admin role and a sponsored group. Sponsor admins can only manage users within their assigned sponsored group. For more information about sponsored groups, see [Sponsored groups on page 240](#).

For *Administrator*, select from one of the available administrator roles from the *Choose an Administrator Role* dropdown.

For *Customized User*, select from one of the available custom roles from the *Choose a custom defined Role* dropdown.



Use the search bar to look for the following:

- Sponsor admin role and group
- Administrator role
- Custom role

For information on the user types and their roles, see [Users in FortiPAM on page 223](#) and [Role on page 243](#).

User Import

Remote Server

From the dropdown, select a remote LDAP server.

In the dropdown, select + to create a new remote LDAP server. See [LDAP servers on page 255](#).



Use the search bar to look for a remote LDAP server.



Hover over a remote LDAP server name to see details about the remote LDAP server.

Click > on the left to open *LDAP DB Structure* and choose a node.

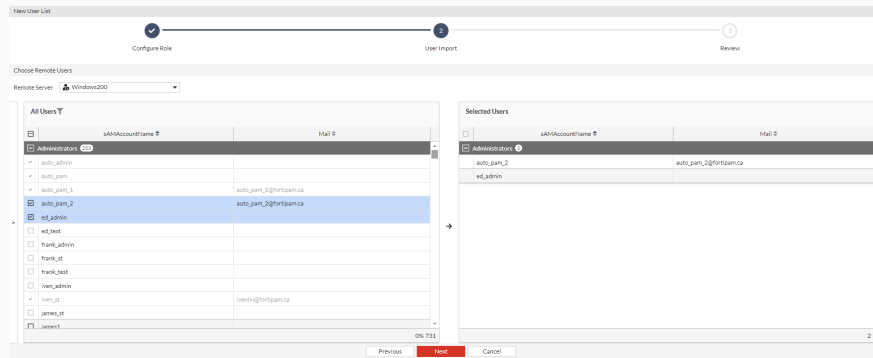

By default, *LDAP DB Structure* is hidden.

In the *All Users* table:

- All the users in the selected remote LDAP server show up.
- To select all the users, select the checkbox in the header.
- To only select some users, select the checkbox before the users.



To define a filter to match username or group, see [Filters on page 25 in Tables on page 25](#).



For other column related settings, see [Column settings on page 28 in Tables on page 25](#).

- Selected users from *All Users* are displayed in the *Selected Users* table.

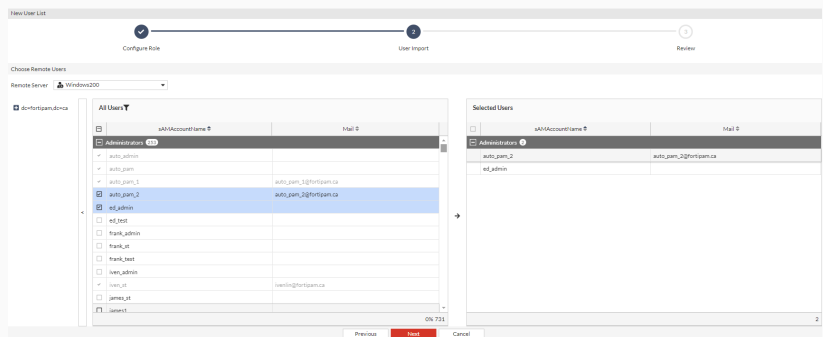

3. In the *Review* tab, verify the information you entered and click *Submit* to import the users.

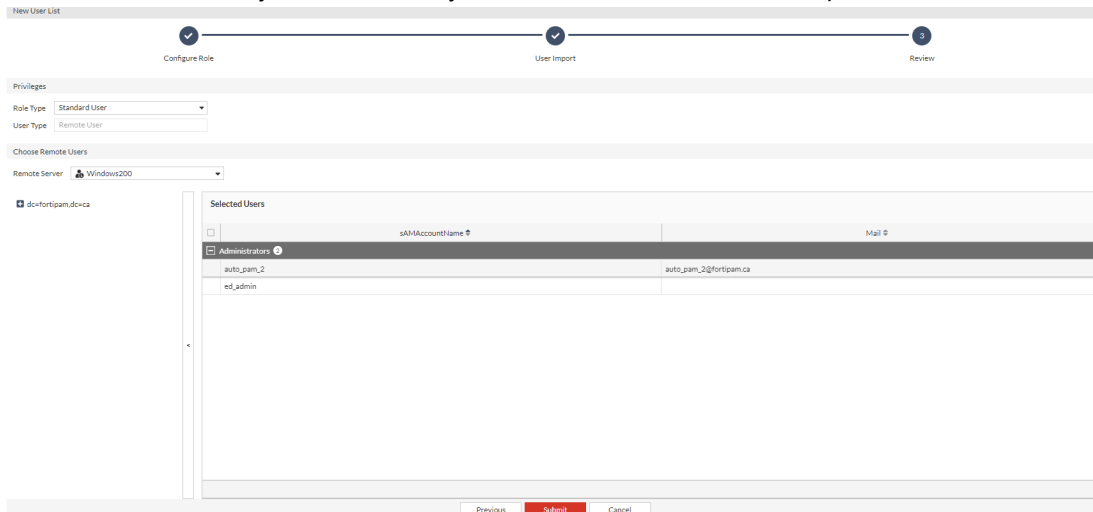

The imported users are listed in *User Management > User List*.

Name	Sponsored Group	Role	Type	Lastest Login	Status	Two-factor Authentication	References
Administrator							
William_2		Default Administrator	Local	2023-11-15 14:39:09	Enable	Disable	2
admin		Super Administrator	Local	2024-02-07 11:31:37	Enable	Disable	19
robert_saml		Default Administrator	Remote	2023-12-01 09:57:04	Enable	Disable	1
stanle_api		Default Administrator	API	Not Available	Enable	Disable	2
Customized User							
robert		Customized_Role	Local		Enable	Disable	5
Power User							
auto_pam		Power User	Remote		Enable	Disable	1
Sponsor Admin							
iver_st	Team2	Sponsor Admin	Remote	2024-01-31 11:28:56	Enable	Disable	1
robert_ldap	Team1	Sponsor Admin	Remote	2024-02-06 14:09:27	Enable	Disable	1
Standard User							
William		Standard User	Local		Enable	FortToken Cloud	2
auto_admin		Standard User	Remote		Enable	Disable	1
auto_pam_1		Standard User	Remote		Enable	Disable	1
auto_pam_2		Standard User	Remote		Enable	Disable	1
ed_admin		Standard User	Remote		Enable	Disable	1
hou_rad		Standard User	Remote		Enable	Disable	0
local_1		Standard User	Local	2024-01-24 15:48:47	Enable	Disable	4
pam13		Standard User	Remote		Enable	Disable	0
pam28_rad		Standard User	Remote		Enable	Disable	1
pam28_saml		Standard User	Remote		Enable	Disable	1
robert2		Standard User	Remote		Enable	Disable	1
robert_admin		Standard User	Remote	2024-01-31 11:38:08	Enable	FortToken Cloud	1
robert_ldap3		Standard User	Remote	2024-02-01 10:44:34	Enable	FortToken Cloud	1
robert_ldap4		Standard User	Remote	2024-02-01 11:08:13	Enable	FortToken Cloud	1
vetritt	Team1	Standard User	Remote		Enable	Disable	1
stanle_saml		Standard User	Remote		Enable	Disable	3

User groups

User Groups in *User Management* displays a list of user groups.

The following two default user groups are available:

- *everyone*: By default, every user belongs to this user group.
- *fortipam_auth_group*: By default, the *Super Administrator* admin user belongs to this user group. Users can be added or removed from this user group.

Name	User Members	Remote Groups	Remote Members
Local User			
everyone			
fortipam_auth_group	admin		
Remote			

Users can be assigned to groups during user account configuration, or by creating or editing the groups to add users to it.

The *User Groups* tab contains the following options:

Create	Select to create a new user group.
Edit	Select to edit the selected user group.
Delete	Select to delete the selected user groups.
Search	Enter a search term in the search field, then hit <code>Enter</code> to search the user groups list. To narrow down your search, see Column filter .

To create a new user group:

1. Go to *User Management > User Groups*.
2. Select *Create* to create a new user group.

The *General* tab in the *Create New User Group* window opens.

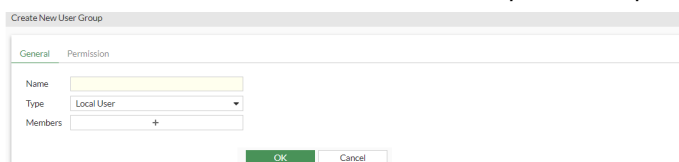

3. To switch to the *Permission* tab, select the tab.

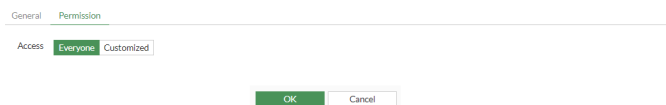

4. In the *General* tab, enter the following information:

Name	Name of the group.
Type	Select the type of the group: <ul style="list-style-type: none"> • <i>Remote</i> • <i>Local User</i>
Members	Select + to add existing members to the user group from the list and select <i>Close</i> , or in the <i>Select Entries</i> window, select + to create a new user. See Creating a user on page 218 .
 Use the search bar to look for a user.	
Remote Groups	By adding a remote server to the user group, the group will contain all user accounts on that server. Optionally, a specific user group on the remote server can be included to restrict the scope to that group. See Creating Remote Groups . Note: This pane is available only when the <i>Type</i> is <i>Remote</i> .



Select remote groups from the list and select *Delete* to delete the remote groups.

Select a remote group from the list and select *Edit* to edit the remote group.

5. Switch to the *Permission* tab and enter the following information:

Access

Select from the following two options:

- *Everyone*: All the members of the user group have complete access to the user group.
- *Customized*: Customize the level of access for members in the user group.

User Permission

The level of user access to the user group. See [User Permission on page 238](#).

Note: The option is only available when *Access* is set to *Customized*.

6. Click *OK*.

To create a new remote group:

1. In the *Create New User Group* window, select *Create in Remote Groups*.
-



The *Remote Groups* pane is only available when the *Type* is *Remote*.

The *Add Group Match* window opens.

2. In *Remote Server* dropdown, select LDAP, RADIUS, and SAML servers:

- a. If an LDAP server is selected, from the remote users list, select the remote users to import.



At least one LDAP server must be already configured. See [LDAP servers on page 255](#).



Hold `ctrl` and click to select multiple users.



To narrow down your search, see [Column filter](#).
You can filter your search by *Group*, or enter a custom filter and select *Apply*.
Enable *Show entries in subtree* to list remote users in the subtree.



LDAP filters consist of one or more clauses which can be combined with logical AND/OR operators.

Filter syntax differs depending on the LDAP server software.

See the following examples - examples:

- Users with given name starting with the letter "h":
`(&(objectClass=person)(givenName=h*))`
 - All groups:
`(&(objectClass=posixGroup)(cn=*))`
-

- b. Optionally, if a RADIUS server is selected, select **+**, and enter group names in *Groups*.



At least one RADIUS server must be already configured. See [RADIUS servers on page 265](#).

- c. Optionally, if a SAML server is selected, select **+**, and enter group names in *Groups*.



At least one SAML server must be already configured.

3. Click *OK* to save changes to group match.



Alternatively, use the CLI commands to create a user group.

User Permission

To set up user permission:

1. In step 5 when [Creating a user group](#), provided that *Access* is set to *Customized*, select *Create* in *User Permission*. The *New User Permission* window opens.

2. Enter the following information:

Users

Select + and from the list, select users in the *Select Entries* window.

To add a new user:

1. From the *Select Entries* window, select + and then select *+UserList*. The *New User List* wizard open.
2. Follow the steps in [Creating a user on page 218](#), starting step 2 to create a new user.



Use the search bar to look up a user.



Use the pen icon next to a user to edit it.

Permission

From the dropdown, select an option:

- *Viewer*: Ability to view the user group.
- *Owner*: The highest possible permission level with the ability to create, edit, and delete user groups.

3. Click *OK*.

CLI configuration to set up an LDAP user group - example:

```
config user group
edit <ldap_group_name>
set member <ldap_server_name>
config match
edit 1
set server-name <ldap_server_name>
set group-name "cn=User,dc=XYA, dc=COM"
next
end
next
end
```

CLI configuration to set up a RADIUS user group - example:

```

config user group
  edit <radius_group_name>
    set member <radius_server_name>
  next
end

```

Auto provision rules

Auto Provision Rules in *User Management* displays a list of auto provision rules for remote users.

Based on the predefined auto provision rules, remote users can be auto provisioned upon their first successful login without requiring the manual creation of a user in the system prior to login:

- You create an auto provision rule for remote users (LDAP, RADIUS, or SAML).
- The user is created automatically on the first successful login.

FortiPAM allows you to automatically sync up users based on group membership without limiting the authentication protocol (LDAP, RADIUS, or SAML).

The auto provision rule includes information about the remote user group and users' role (access profile) on auto provision. The type of role depends on the user's group membership.

Based on the group, FortiPAM decides if the user can log in to FortiPAM and the type of permission the user is granted. Once the user logs in, the user is automatically created and listed in *User Management > User List*.

Name	Role	Type	Lastest Login	Status	Created By	Provision Rule
ldap_6	Standard User	Remote	2024-01-08 10:51:43	Enable	Auto Provision	Out of Sync
ldap_7	Standard User	Remote	2024-01-05 13:58:22	Enable	Auto Provision	Out of Sync
ldap_8	Standard User	Remote		Enable	Auto Provision	Out of Sync
ldap_9	Standard User	Remote	2024-01-08 11:11:55	Enable	Auto Provision	Out of Sync
ldap_12	Standard User	Remote	2024-01-08 11:15:57	Enable	Manual Creation	
ldap_14	Standard User	Remote	2024-01-08 11:21:55	Enable	Manual Creation	
ldap_15	Standard User	Remote	2024-01-08 11:24:44	Enable	Manual Creation	
ldap_16	Standard User	Remote	2024-01-08 11:35:07	Enable	Manual Creation	
ldap_18	Standard User	Remote	2024-01-08 11:50:13	Enable	Auto Provision	Out of Sync
ldap_19	Standard User	Remote	2024-01-08 11:51:36	Enable	Auto Provision	Out of Sync
ldap_21	Standard User	Remote	2024-02-28 14:09:54	Enable	Auto Provision	ldap_grp2_std
ldap_24	Standard User	Remote	2024-01-11 12:02:29	Enable	Auto Provision	Out of Sync
ldap_25	Standard User	Remote	2024-01-11 12:08:27	Enable	Auto Provision	Out of Sync
m1	Standard User	Local		Enable	Manual Creation	
m2	Standard User	Local		Enable	Manual Creation	
m3	Standard User	Local		Enable	Manual Creation	
pam15_rad2	Standard User	Remote	2024-02-28 14:12:27	Enable	Auto Provision	radius_grp1
role_audit	Standard User	Local		Enable	Manual Creation	



The order of the rules impacts the login matching. First, the rule is matched from top to bottom.



The rules can be reordered by dragging a rule up/down from the left-most row.



Disabling or deleting a rule, or changing the *From Remote Group* setting for a rule results in users becoming out-of-sync, which means the current user might not match any rule until the next successful login.



Out-of-sync users do not occupy license seats.

For each auto provision rule, the following columns are displayed by default:

- *Name*
- *Status*
- *Description*
- *As Role*
- *From Remote Group*

	Name	Status	Description	As Role	From Remote Group
<input type="checkbox"/>	rule_1	Enabled		Standard User	test_user_grp

The *Auto Provision Rules* tab contains the following options:

Create	Select to create a new auto provision rule. See Creating an auto provision rule on page 263 .
Search	Enter a search term in the search field, then hit <code>Enter</code> to search the auto provision rules list. To narrow down your search, see Column filter .
Edit	Select to edit the selected auto provision rule.
Enable/Disable	Select to enable/disable the selected auto provision rule.
Delete	Select to delete the selected auto provision rule.
List Provisioned Users	Select to see the list of provisioned users in a new window for the selected auto provision rule.

To set up auto provisioning rule using the CLI, see [Setting up remote user auto provisioning using the CLI on page 265](#).

Sponsored groups

Super administrators can create sponsored groups, defining a maximum number of users for each group. These groups can then have sponsor admins assigned to them. Those sponsor admins can only access logs for their specific secrets. This includes creating, editing, disabling, and deleting users within their sponsored group.

Super administrators can assign the sponsor admin role and sponsored group when creating or editing users. Multiple sponsor admins can be assigned to a single sponsored group.

The sponsor role benefits the customers needing more visibility on the contractors' users. It aims to manage those contractors efficiently and balance the administrators' workload by designating sponsor admins managing sponsored groups.

Sponsored Groups in *User Management* displays a list of sponsored groups.

For each sponsored group; name, maximum number of users, and members are shown.

+ Create	Q Search		
	Name	Sponsored Group Maximum Size	Sponsor Members
<input type="checkbox"/>	sponsored_grp_1	10	

The *Sponsored Groups* tab contains the following options:

Create	Select to create a new sponsored group.
Edit	Select to edit the selected sponsored group.
Delete	Select to delete the selected sponsored groups.
Search	Enter a search term in the search field, then hit Enter to search the sponsored groups list. To narrow down your search, see Column filter .

To create a new sponsored group:

1. Go to *User Management > Sponsored Groups*.
2. Select *Create* to create a new user group.
The *General* tab in the *Create New Sponsored Group* window opens.

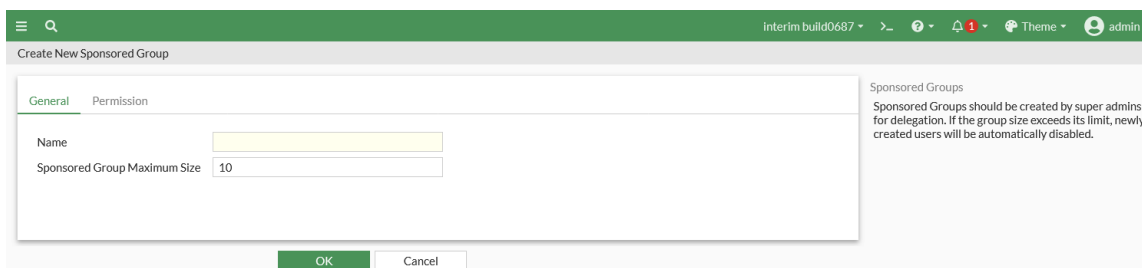

3. In the *General* tab, enter the following information:

Name	Name of the group.
Sponsored Group Maximum Size	Enter the maximum number of users that can be assigned to the sponsored group.

- To switch to the *Permission* tab, select the tab.

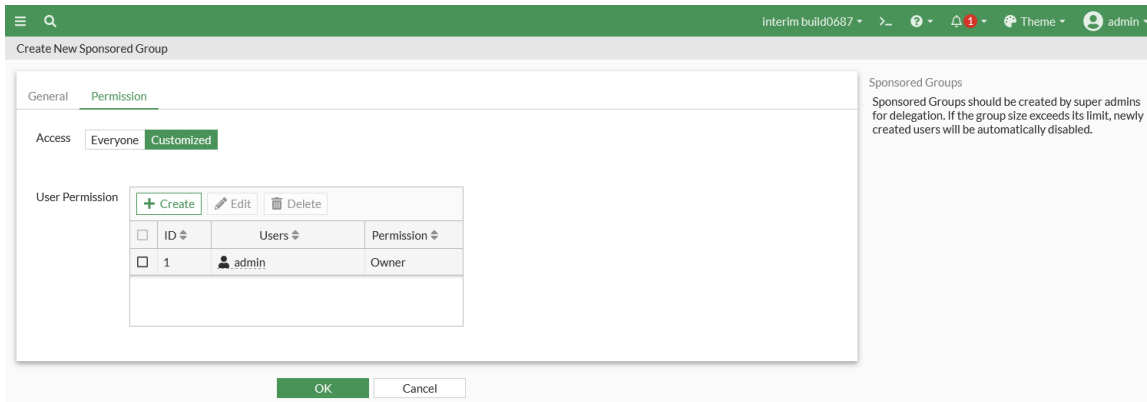

- In the *Permission* tab, enter the following information:

Access

Select from the following two options:

- Everyone*: All the members of the sponsored group have complete access to the sponsored group.
- Customized*: Customize the level of access for members in the sponsored group.

User Permission

The level of user access to the sponsored group. See [User Permission on page 242](#).

Note: The option is only available when *Access* is set to *Customized*.



- Click **OK**.

User Permission

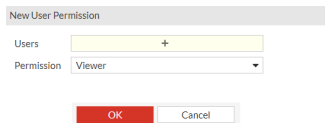
- In step 4 when [Creating a sponsored group](#), with *Customized* selected in *Access*, select *Create* in *User Permission*. The *New User Permission* window opens.



2. Enter the following information:

Users	Select + and from the list, select users in the <i>Select Entries</i> window. To add a new user: <ol style="list-style-type: none">From the <i>Select Entries</i> window, select +, and then select <i>+User List</i>. The <i>New User List</i> wizard opens.Follow the steps in Creating a user on page 218, starting step 2 to create a new user. <hr/>  Use the search bar to look up a user. <hr/>  Use the pen icon next to a user to edit it. <hr/>
Permission	From the dropdown, select an option: <ul style="list-style-type: none"><i>Viewer</i>: Ability to view the sponsored group.<i>Owner</i>: The highest possible permission level with the ability to create, edit, disable, and delete users within the sponsored group.

3. Click *OK*.

Role

Roles or access profiles define what a user can do when logged into FortiPAM.

When a new user is created, it must have a specific role. See [Creating a user on page 218](#).



When you create a standard user, a default normal user role is assigned to the new user automatically.



When setting up an administrator, administrator roles can be selected from the *Choose an Administrator Role* dropdown. See [Creating a user on page 218](#). The administrator role decides what the administrator can see.

Go to *Roles* in *User Management* to see a list of configured roles.

Name	Comment	Secret	System	User & Device	Log & Report	References
Default Administrator		Read / Write	Read / Write	Read / Write	Read / Write	0
Guest User		None	None	None	None	0
Power User		Read / Write	None	None	None	0
Sponsor Admin		Custom	Custom	None	None	0
Standard User		None	None	None	None	1
Super Administrator		Read / Write	Read / Write	Read / Write	Read / Write	2

There are six default roles:



Default roles cannot be edited.

- **Default Administrator:** Read/write access same as a super administrator, but no access to maintenance mode and glass breaking.
- **Guest User:** For demonstration purposes only. Guest users can only view secrets and have restricted access to FortiPAM features.
- **Power User:** For managing general secret settings, e.g., a power user can change who approves secrets, commands blocked on the target server, etc.
- **Sponsor Admin:** For managing users assigned to their sponsored group. This includes creating, editing, and deleting users assigned to their sponsored group. Sponsor admins can only access logs and reports for their specific users, groups, and secrets.

The sponsored group is selected when creating the sponsor admin user.



The **Sponsor Admin** user has *View Secret Log* and *View Secret Video* permissions by default.

- **Standard User:** Logs in, makes requests for resources, and connect to the privileged resources.



Users with **Standard User** role do not have the privilege to manage FortiPAM devices.

- **Super Administrator:** Privilege to manage and monitor the FortiPAM device. Users with **Super Administrator** role also include privilege of secret server.
- The **Roles** tab contains the following options:

Create	Select to create a new role.
Edit	Select to edit the selected role.
Delete	Select to delete the selected roles.
Search	Enter a search term in the search field, then hit <code>Enter</code> to search the roles list. To narrow down your search, see Column filter .

To create a role:

1. Go to *User Management > Role*, and select *Create*.
The *Secret* tab in the *New User Role* window opens.

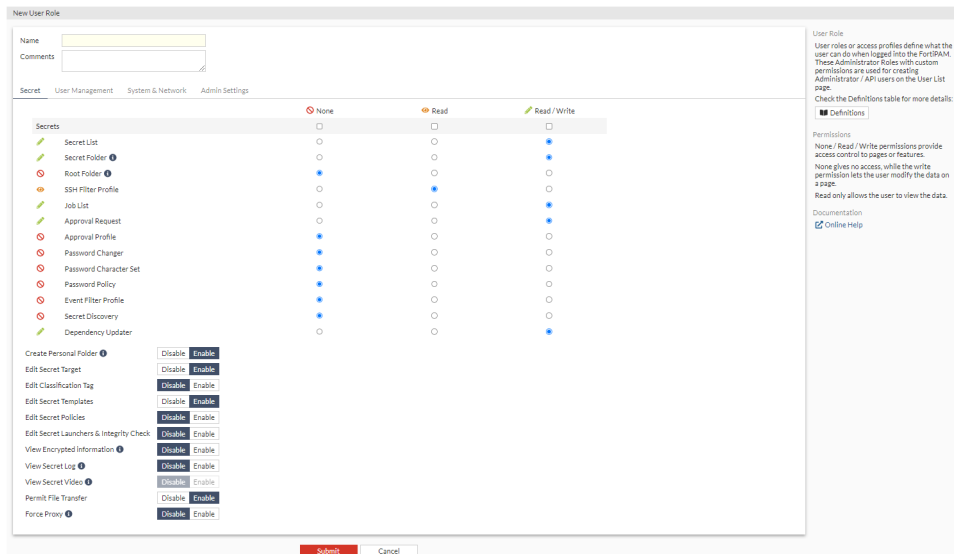

Pages and features are organized and separated into different access controls.

There are two types of access controls:

- **Radio:** Provides *None*, *Read*, and *Read/Write* access.
- **Switch:** Enable/disable a feature.

For each feature, select from the following access levels:

- **None**
- **Read:** View access.

Note: When an administrator has only read access to a feature, the administrator can access the GUI page and can use the `get` and `show` CLI command for that feature, but cannot make changes to the configuration.

- **Read/Write:** View, change, and execute access.

2. Enter the following information:

Name	The name of the role.
Comment	Optionally, enter comments about the role.
Secret	Select <i>None</i> , <i>Read</i> , or <i>Read/Write</i> to set access level globally for all the secret features.
Secret List	Set the access level for Secret list page. It also controls whether pages: <i>Secret Templates</i> , <i>Policies</i> and <i>Launchers</i> can be viewed.
Secret Folder	Set the access level for <i>Folders</i> . Note: You can restrict the corresponding folder and secret permissions under a specific secret.
Root Folder	Permission to create folders in <i>Root</i> .

	Note: The <i>Secret Folder</i> must be set to at least <i>Read</i> permission to enable accessing the root folder.
SSH Filter Profile	Set the access level for <i>SSH Filter Profiles</i> page.
Job List	Set the access level for <i>Jobs List</i> page.
Approval Request	Set the access level for <i>My Request</i> and <i>Request Review</i> page in <i>Approval Request</i> .
Approval Profile	Set the access level for <i>Approval Profile</i> page in <i>Approval Flow</i> .
Password Changer	Set the access level for <i>Password Changers</i> page in <i>Password Changing</i> .
Password Character Set	Set the access level for <i>Character Sets</i> page in <i>Password Changing</i> .
Password Policy	Set the access level for <i>Password Policies</i> page in <i>Password Changing</i> .
Event Filter Profile	Set the access level for <i>Event Filter Profile</i> page.
Secret Discovery	Set the access level for the <i>Discovery</i> page.
Dependency Updater	
Create Personal Folder	Enable/disable creating a personal folder right after the user is created. Note: The <i>Secret Folder</i> permission must be <i>Read/Write</i> .
Edit Secret Target	Enable/disable editing the targets.
Edit Classification Tag	Enable/disable editing the <i>Classification Tag</i> page.
Edit Secret Templates	Enable/disable editing the <i>Templates</i> page.
Edit Secret Policies	Enable/disable editing the <i>Policies</i> page.
Edit Secret Launchers & Integrity Check	Enable/disable editing the <i>Launchers</i> and the <i>Integrity Check</i> pages.
View Encrypted Information	Enable/disable viewing the secret password, passphrase, and ssh-key. Note: <i>Secret List</i> must be set to <i>Read/Write</i> permission to view the encrypted secret information.
View Secret Log	Enable/disable viewing secret modification history, launch activity logs, and SSH filter logs (for SSH launcher) in the <i>Secret Details</i> page when editing/viewing a secret in <i>Secrets > Secret List</i> . When enabled, the following tabs are available when editing/viewing a secret: <ul style="list-style-type: none"> • <i>Edit History</i> • <i>Activity</i> • <i>SSH Filter Log</i>
View Secret Video	Enable/disable viewing secret launch videos. Note: The option is only available when <i>View Secret Log</i> is enabled.
Permit File Transfer	Enable/disable permitting file transfer.
Force Proxy	Enable/disable launching secrets in the proxy mode. Note: The option is disabled by default.

3. Select the *User Management* tab.
The *User Management* tab opens.

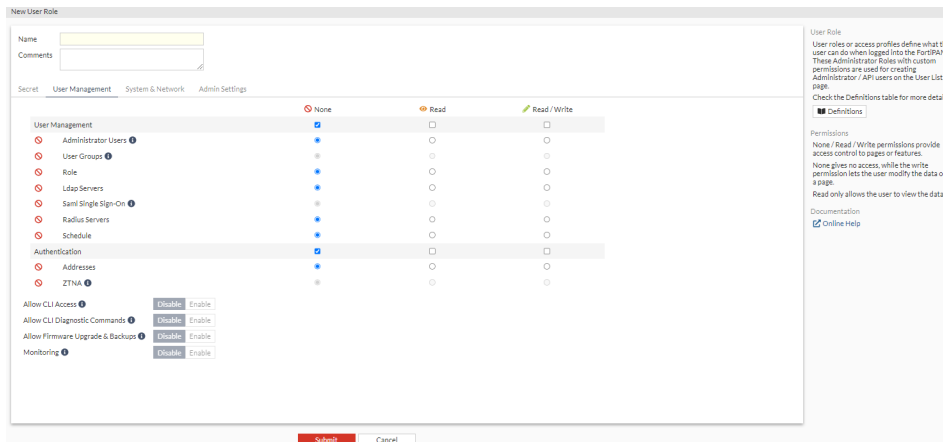

4. Enter the following information:

User Management

Select *None*, *Read*, or *Read/Write* to set access level globally for all the user management features.

Administrator Users

Set the access level for the *User List* page in *User Management* and the *Backup* page in *System*.

User Groups

Set the access level for *User Groups* page in *User Management*.

Note: *Ldap Servers*, *Saml Single Sign-On*, and *Radius Servers* must be set to at least *Read* permission to access *User Groups*.

Role

Set the access level for *Role* page in *User Management*.

Ldap Servers

Set the access level for *Ldap Servers* page in *User Management*.

Note: *Scheme & Rules* must be set to at least *Read* permission to access LDAP servers.

Saml Single Sign-On

Set the access level for *Saml Single Sign-On* page in *User Management*.

Note: *Addresses* and *Scheme & Rules* must be set to at least *Read* permission to access SAML servers.

Radius Servers

Set the access level for *Radius Servers* page in *User Management*.

Note: *Scheme & Rules* must be set to at least *Read* permission to access RADIUS servers.

Schedule

Set the access level for *Schedule* page in *User Management*.

Authentication

Select *None*, *Read*, or *Read/Write* to set access level globally for all the authentication features.

Addresses

Set the access level for *Addresses* page in *Authentication*.

ZTNA

Set the access level for *ZTNA* page in *System*.

Note: This requires the same permission as *Schedule* and *Addresses*.

- Examples

- If all required permissions are *Read/Write*, the ZTNA can only be either

	<p><i>None</i> or <i>Read/Write</i>.</p> <ul style="list-style-type: none"> If <i>Schedule</i> is set to <i>Read</i> and the rest is set to <i>Read/Write</i>, <i>ZTNA</i> can only be <i>None</i>.
Allow CLI Access	<p>Enable/disable CLI access.</p> <p>Note: The <i>Administrator Users</i> must be set to <i>Write</i> permission to have CLI access.</p>
Allow CLI Diagnostic Commands	<p>Enable/disable access to diagnostic CLI commands.</p> <p>Note: <i>System Configuration</i> must be set to <i>Write</i> permission to manage system certificates.</p>
	 <p>The role must have <i>Allow CLI Access</i> enabled to access the diagnostic commands.</p>
Allow Firmware Upgrade & Backups	<p>Enable/disable permission to use firmware upgrades and configuration backup features.</p>
Monitoring	<p>Enable/disable access to the pages under <i>Monitoring</i>.</p> <p>Note: This requires the same permission as <i>User Groups</i>, <i>Ldap Servers</i>, <i>Saml Single Sign-On</i>, and <i>Radius Servers</i>.</p>

- Select the *System & Network* tab. The *System & Network* tab opens.

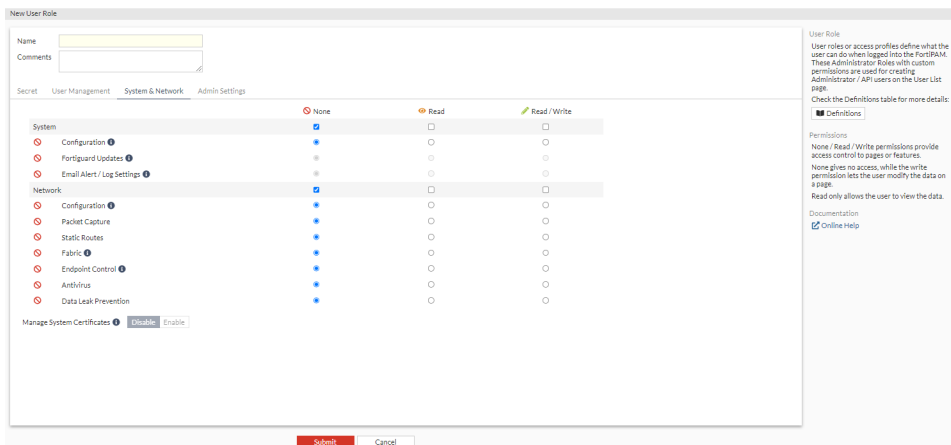

- Enter the following information:

System

Select *None*, *Read*, or *Read/Write* to set access level globally for all the system features.

Configuration

Set the access level for:

- DNS Settings* in *Network*.
- SNMP*, *Settings*, and *HA* pages in *System*.
- VM License uploading; *System Reboot*, and *Shutdown* settings.
- Configuration Revisions* and *Scripts*.

FortiGuard Updates	Set the access level for <i>FortiGuard</i> page from <i>Dashboard</i> . The <i>System Configuration</i> is set to <i>Write</i> to have access to the <i>FortiGuard</i> page.
Email Alert/Log Settings	Set the access level for <i>Email Alert Settings</i> and <i>Log Settings</i> in <i>Log & Report</i> . Note: <ul style="list-style-type: none"> The <i>Fabric</i> and <i>System Configuration</i> is set to <i>Write</i> to have full access to the <i>Log Settings</i> page. The <i>View Reports</i> access needs to be enabled to have settings, <i>Local Reports</i> and <i>Historical FortiView</i> in the <i>Log Settings</i> page.
Network	Select <i>None</i> , <i>Read</i> , or <i>Read/Write</i> to set access level globally for all the network features.
Configuration	Set the access level for <i>Interfaces</i> page in <i>Network</i> .
Packet Capture	Set the access level for <i>Packet Capture</i> page in <i>Network</i> .
Static Routes	Set the access level for <i>Static Routes</i> page in <i>Network</i> .
Fabric	Set the access level for <i>FortiAnalyzer Logging</i> card on the <i>Fabric Connectors</i> page in <i>Security Fabric</i> .
Endpoint Control	Set the access level for <i>FortiClient EMS</i> card on the <i>Fabric Connectors</i> page in <i>Security Fabric</i> and <i>ZTNA Tags</i> in <i>System > ZTNA</i> .
Antivirus	Set the access level for the <i>AntiVirus</i> page in <i>Secret Settings</i> . If the access level is set to <i>Read</i> or <i>None</i> , <i>Use Extreme AVDB</i> and <i>AntiVirus PUP/PUA</i> in FortiGuard license on page 382 are either disabled or shown as <i>Not Available</i> . Note: This also controls the <i>AntiVirus</i> settings in the <i>FortiGuard License</i> page in <i>System</i> .
Data Leak Prevention	Set the access level for the <i>Data Leak Prevention</i> and <i>DLP File Pattern</i> pages in <i>Secret Settings</i> .
Manage System Certificates	Enable/disable accessing the <i>Certificates</i> page in <i>System</i> . Note: <i>System Configuration</i> must have the <i>Write</i> permission.

- Select the *Admin Settings* tab.
The *Admin Settings* tab opens.

8. Enter the following information:

Access FortiPAM GUI	Enable/disable accessing FortiPAM GUI.
Enter Glass Breaking Mode	Enable/disable glass breaking mode. Note: The glass breaking mode gives you access to all secrets in the system.
Set Maintenance Mode	Enable/disable maintenance mode. Note: Suspend all critical processes to allow maintenance related activities.
View Logs	Enable/disable viewing <i>Events</i> , <i>Secrets</i> , <i>ZTNA</i> , and <i>SSH</i> logs in <i>Log & Report</i> .
View Reports	Enable/disable viewing <i>Reports</i> in <i>Log & Report</i> .
View Secret Launching Video	Enable/disable viewing playback videos in <i>Secret Video</i> . Note: <i>View Logs</i> must be enabled since the secret videos are available in <i>Log & Report > Secret</i> page.
Override Idle Timeout	Enable to override the idle timeout.
Never Timeout	Enable to never timeout. Note: The option is disabled by default.
Offline	Set the time after which the user with the role goes offline, in minutes (1 - 480, default = 10).

9. Click *Submit*.



Alternatively, you can also use the CLI to create roles.

CLI configuration to set up a user role - example:

```
config system accprofile
  edit "Default Administrator"
    set secfabgrp read-write
```

```

set ftviewgrp read-write
set authgrp read-write
set sysgrp read-write
set netgrp read-write
set loggrp read-write
set fwgrp read-write
set vpngrp read-write
set utmgrp read-write
set wanoptgrp read-write
set secretgrp read-write
set cli enable
set system-diagnostics enable
next
edit "pam_standard_user"
set secfabgrp read
set ftviewgrp read
set authgrp read
set secretgrp custom
set system-diagnostics disable
config secretgrp-permission
set launcher read
set pwd-changer read
set template read-write
set secret-policy read
set request read-write
set folder-table read-write
set secret-table read-write
set create-personal-folder read-write
end
next

```

Access control options

When creating or editing a role, select *Definitions* to see access control definitions.

Access Control	Definition
Secrets	
Secret List	It controls access to the Secret list page. It also controls whether pages: <i>Secret Templates</i> , <i>Policies</i> and <i>Launchers</i> can be viewed.
Secret Folder	Controls the access to <i>Folders</i> . Note: You can restrict the corresponding folder and secret permissions under a specific folder and secret.
Root Folder	Permission to create folders in <i>Root</i> .
SSH Filter Profile	Access to the <i>SSH Filter Profiles</i> page.
Job List	Access to the <i>Job List</i> page.
Approval Request	Access to the <i>My Request</i> and <i>Request Review</i> page in <i>Approval Request</i> .

Access Control	Definition
Approval Profile	Access to the <i>Approval Profile</i> page in <i>Approval Flow</i> .
Password Changer	Access to <i>Password Changers</i> page in <i>Password Changing</i> .
Password Character Set	Access to <i>Character Sets</i> page in <i>Password Changing</i> .
Password Policy	Access to <i>Password Policies</i> page in <i>Password Changing</i> .
Event Filter Profile	Enable/disable creating event filter profiles.
Create Personal Folder	Enable/disable creating a personal folder right after the user is created.
Edit Secret Target	Enable/disable editing secret targets.
Edit Classification Tag	Enable/disable editing the <i>Classification Tag</i> page.
Edit Secret Templates	Enable/disable editing the <i>Secret Templates</i> page.
Edit Secret Policies	Enable/disable editing the <i>Policies</i> page.
Edit Secret Launchers & Integrity Check	Enable/disable editing the <i>Secret Launchers</i> and the <i>Integrity Check</i> pages.
View Encrypted information	Enable/disable viewing the secret password, passphrase, and ssh-key. This requires <i>Read/Write</i> permission for the <i>Secret List</i> .
View Secret Log	Enable/disable viewing secret logs (<i>Edit History</i> , <i>Activity</i> , and <i>SSH Filter Log</i> tabs) when editing a secret (<i>Secret Details</i> window).
View Secret Video	Enable/disable viewing secret video when editing a secret (<i>Secret Details</i> window). Note: This only takes effect when <i>View Secret Log</i> is already enabled.
Permit File Transfer	Enable/disable launching file launchers. These are designated to send files.
Force Proxy	Enable/disable forcing user with this account profile to always launch with proxy.
User Management	
Administrator Users	Access to the <i>User List</i> page in <i>User Management</i> and the <i>Backup</i> page in <i>System</i> .
User Groups	Access to the <i>User Groups</i> page in <i>User Management</i> .
Role	Access to the <i>Role</i> page in <i>User Management</i> .
Ldap Servers	Access to the <i>Ldap Servers</i> page in <i>User Management</i> .
Saml Single Sign-On	Access to the <i>Saml Single Sign-On</i> page in <i>User Management</i> .
Radius Servers	Access to the <i>Radius Servers</i> page in <i>User Management</i> .
Schedule	Access to the <i>Schedule</i> page in <i>User Management</i> .
Allow CLI Access	Enable/disable CLI access.
Allow CLI Diagnostic Commands	Enable/disable access to diagnostic CLI commands.

Access Control	Definition
Allow Firmware Upgrade & Backups	Enable/disable permission to use firmware and configuration backup features.
Monitoring	Access to pages in <i>Monitoring</i> . Note: This requires the same permission as <i>User Groups</i> , <i>Ldap Servers</i> , <i>Saml Single Sign-On</i> , and <i>Radius Servers</i> .
Authentication	
Addresses	Access to the <i>Addresses</i> page.
ZTNA	Access to the <i>ZTNA</i> page in <i>System</i> . ZTNA requires the same permission as <i>Schedule</i> and <i>Addresses</i> . Examples - Example: <ul style="list-style-type: none"> • If all the required permissions are <i>Read/Write</i>, ZTNA can be either <i>None</i> or <i>Read/Write</i>. • If <i>Schedule</i> is set to <i>Read</i> and the rest is <i>Read/Write</i>, ZTNA is <i>None</i>.
Network	
Configuration	Access to the <i>Interfaces</i> page in <i>Network</i> .
Packet Capture	Access to the <i>Packet Capture</i> page in <i>Network</i> .
Static Routes	Access to the <i>Static Routes</i> page in <i>Network</i> .
Fabric	Access to the <i>FortiAnalyzer Logging</i> card on the <i>Fabric Connectors</i> page in <i>Security Fabric</i> .
Endpoint Control	Access to the <i>FortiClient EMS</i> card on the <i>Fabric Connectors</i> page in <i>Security Fabric</i> .
Antivirus	Access to the <i>AntiVirus</i> page. Notes: <ul style="list-style-type: none"> • This also controls the <i>Antivirus</i> settings in the <i>FortiGuard Distribution Network</i> page. • Use Extreme AVDB and AntiVirus PUP/PUA settings in the <i>FortiGuard Distribution Network</i> page are disabled or shown as unavailable if the role has Read-Only or no access permission.
Data Leak Prevention	Access to the <i>Data Leak Prevention</i> and the <i>DLP File Pattern</i> pages.
Manage System Certificates	Enable/disable accessing the <i>Certificates</i> page in <i>System</i> .
System	
Configuration	Access to: <ul style="list-style-type: none"> • <i>DNS Settings</i> in <i>Network</i>. • <i>SNMP</i>, <i>Settings</i>, and <i>HA</i> pages in <i>System</i>. • VM License uploading; <i>System Reboot</i>, and <i>Shutdown</i> settings. • <i>Configuration Revisions</i> and <i>Scripts</i>.
FortiGuard Updates	Access to the <i>FortiGuard</i> page from <i>Dashboard</i> .
Email Alert/Log Settings	Access to <i>Email Alert Settings</i> and <i>Log Settings</i> in <i>Log & Report</i> .

Access Control	Definition
Admin Settings	
Access FortiPAM GUI	Enable/disable accessing FortiPAM GUI.
Enter Glass Breaking Mode	Enable/disable glass breaking mode.
Set Maintenance Mode	Enable/disable maintenance mode.
View Logs	Enable/disable viewing <i>Events</i> , <i>Secrets</i> , <i>ZTNA</i> , and <i>SSH</i> logs in <i>Log & Report</i> .
View Reports	Enable/disable viewing <i>Reports</i> in <i>Log & Report</i> .
View Secret Launching Video	Enable/disable viewing playback videos in <i>Secret Video</i> .

Log permissions

Use the following chart to confirm the level of log access depending on user/user group permission for the secret and log permission for the role that applies to the user:

Secret Permission				Role Permission			Result		
List	View	Edit	Owner	View Secret Log	View Secret Video	View Global Log	Log from Secret	Video from Secret	Global Log
✓						✓	NO	NO	YES
	✓					✓	Yes	Yes	Yes
		✓				✓	Yes	Yes	Yes
			✓			✓	Yes	Yes	Yes
✓				✓			No	No	No
	✓			✓			Yes	No	No
		✓		✓			Yes	No	No
			✓	✓			Yes	No	No
✓				✓	✓		No	No	No
	✓			✓	✓		Yes	Yes	No
		✓		✓	✓		Yes	Yes	No
			✓	✓	✓		Yes	Yes	No
✓							No	No	No
	✓						No	No	No
		✓					No	No	No
			✓				No	No	No

Sponsor Admin									
List	View	Edit	Owner	View Secret Log	View Secret Video	View Global Log	Log from Secret	Video from Secret	Global Log
✓				✓	✓		No	No	No
	✓			✓	✓		Yes	Yes	No
		✓		✓	✓		Yes	Yes	No
			✓	✓	✓		Yes	Yes	No

Notes:

- For users with *View Secret Log* and *View Secret Video* permissions without global log access, at least *View* permission is the precondition to check logs from the *Secret Details* window. Users with global log access can bypass the precondition.
- The *Sponsor Admin* user has *View Secret Log* and *View Secret Video* permissions by default.

LDAP servers

Users can use remote authentication servers, such as an LDAP server, to connect to FortiPAM.

LDAP servers store users' information including credentials and group membership. This information can authenticate FortiPAM remote users and provide groups for authorization.

Go to *LDAP servers* in *User Management* to see a list of LDAP servers.

Name	Server	Port	Common Name Identifier	Distinguished Name	References
windows-ad	10.1.100.200	389	cn	dc=fortipam,dc=ca	5

The *LDAP server* tab contains the following options:

Create	Select to create an LDAP server.
Edit	Select to edit the selected LDAP server.
Delete	Select to delete the selected LDAP roles.
Search	Enter a search term in the search field, then hit <code>Enter</code> to search the LDAP servers list. To narrow down your search, see Column filter .

To create an LDAP server:

1. Go to *User Management > LDAP servers*, and select *Create*.
The *New LDAP Server* wizard opens.

2. Enter the following information, and click *Next* after each tab:

Set up server	
Name	Name of the server.
Server IP/name	The IP address or FQDN for this remote server.
Server Port	The port number for LDAP traffic (default = 636).
Common Name Identifier	The common name identifier for the LDAP server. Most LDAP servers use <code>cn</code> . However, some servers use other common name identifiers such as <code>UID</code> . (default = <code>cn</code>).
Distinguished Name	The distinguished name is used to look up entries on the LDAP server. The distinguished name reflects the hierarchy of LDAP database object classes above the common name identifier.
Secure Connection	Enable to use a secure LDAP server connection for authentication. Secure LDAP (LDAPS) allows for the encryption of LDAP data in transit when a directory bind is being established, thereby protecting against credential theft. Note: This option is enabled by default.
Password Renewal	Enable to allow LDAP users to renew passwords. Note: This option is only available when <i>Secure Connection</i> is enabled. Note: This option is enabled by default.
Protocol	When <i>Secure Connection</i> is enabled, select either <i>LDAPS</i> or <i>STARTTLS</i> (default).
Certificate	When <i>Secure Connection</i> is enabled, select the certificate from the dropdown.
	
Use the search bar to look up a certificate.	
Server Identity Check	Enable to verify server domain name/IP address against the server certificate.

	<p>Note: This option is only available when <i>Secure Connection</i> is enabled.</p> <p>Note: This option is enabled by default.</p>
Advanced Group Matching	<p>Group member check determines whether user or group objects' attributes are used for matching. Group Filter is the filter used for group matching. Member attribute is the name of the attribute from which to get the group membership.</p> <hr/> <div style="display: flex; align-items: center;">  <p>Depending on the LDAP server, you may need to configure additional properties to ensure LDAP groups are correctly matched.</p> </div> <hr/> <p>Note: The option is disabled by default.</p>
Group Member Check	From the dropdown, select a group member check option (default = <code>Ldap::grp::member::check:user-attr</code>).
Group Filter	Enter the group filter for group matching.
Group Search Base	Enter the search base used for searching a group.
Member Attribute	Specify the value for this attribute. This value must match the attribute of the group in LDAP server. All users part of the LDAP group with the attribute matching the attribute will inherit the administrative permissions specified for this group (default = <code>memberof</code>).
Authenticate	
Username	The username.
Password	The password.

- Click *Test connection* to test the connection to the LDAP server.



Test connection is only available to users who have *Write* permission for *Ldap Servers*. See [Role on page 243](#).

If the credentials to the server are valid, it shows *Successful*.

- In the *Review* tab, verify the information you entered and click *Submit* to create the LDAP server.



Use the pen icon to edit tabs.



Alternatively, use the CLI commands to create LDAP servers.

CLI configuration to set up an LDAP server - example:

```
config user ldap
edit <name>
set server <server_ip>
```

```

set cnid "cn"
set dn "dc=XYZ,dc=fortinet,dc=COM"
set type regular
set username <ldap_username>
set password <password>
next
end
config authentication scheme
edit "fortipam_auth_scheme"
set method form
set user-database "local-admin-db" <ldap_server_name>
next
end

```

Setting up remote LDAP authentication includes the following steps:

1. Configuring the LDAP server. See [Configuring an LDAP server](#).
2. Adding the LDAP server to a user group. See [User groups on page 234](#).
3. Configuring the administrator account. See [Creating a user on page 218](#).

SAML Single Sign-On (SSO)

SAML SSO can be configured in *User Management*.

FortiPAM acts as the SP in SAML authentication. The SAML server defines the configuration between SP and IdP. An IdP can authenticate FortiPAM remote users and provide groups for authorization.

To create a SAML SSO server:

1. Go to *User Management > Saml Single Sign-On*.

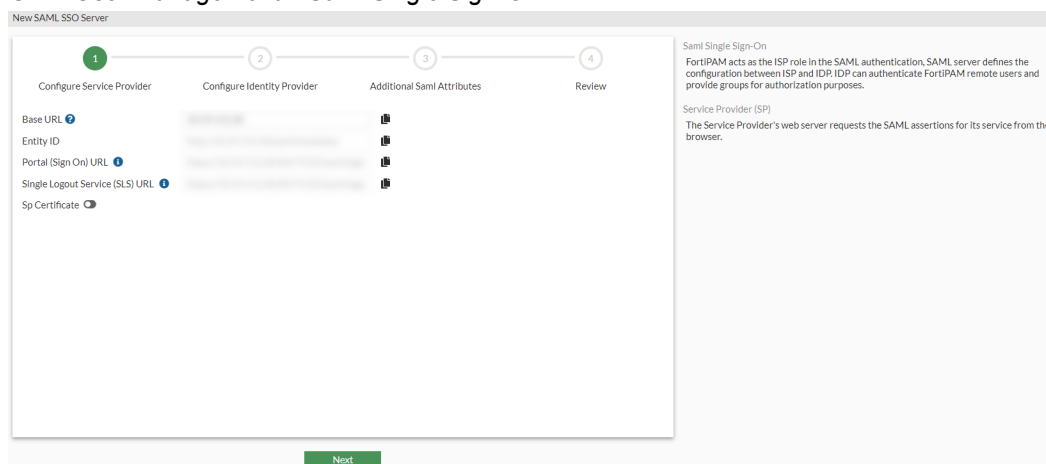

2. Enter the following information, and click *Next* after each tab:

Configure Service Provider

Base URL	<p>The URL where the Identity Provider (IdP) sends SAML authentication requests.</p> <p>Note: The address should be WAN-accessible and can be an IP address or an FQDN.</p> <p>Note: To include a port, append it after a colon. For example: 200.1.1.1.:443.</p>
Entity ID	Enter the SP entity ID.
Portal (Sign On) URL	<p>The SAML service provider login URL. The URL is used to initiate a single sign-on.</p> <p>Note: Not all IdPs require a <i>Portal (Sign On) URL</i>.</p> <p>Note: The <i>Portal (Sign On) URL</i> is alternatively referred to as the Portal URL or the Sign On URL.</p>
Single Logout Service (SLS) URL	<p>The SP Single Logout Service (SLS) logout URL. The IdP sends the logout response to this URL.</p> <p>Note: The <i>Single Logout Service (SLS) URL</i> is alternatively referred to as the SLS URL, Single Logout Service URL, or the Logout URL.</p>
Sp Certificate	<p>Enable this option and import the SP certificate for authentication request signing by the SP.</p> <p>Note: This option is disabled by default.</p>
<p>Configure Identity Provider</p> <p>An IdP provides SAML assertions for the service provider and redirects the user's browser back to the service provider web server.</p>	
 <p>Log in to the IdP to find the following information.</p>	
Type	Select either <i>Fortinet Product</i> or a <i>Custom</i> IdP.
IdP Address	<p>The IdP address.</p> <p>Note: This option is only available when the <i>Type</i> is <i>Fortinet Product</i>.</p>
Prefix	<p>Enter the IdP prefix.</p> <p>Note: The prefix is appended to the end of the IdP URLs.</p> <p>Note: This option is only available when the <i>Type</i> is <i>Fortinet Product</i>.</p>
IdP Certificate	<p>Select a server certificate to use for the SP.</p> <hr/> <div style="display: flex; align-items: center;">  <p>Whenever the configuration changes on the IdP, you need to upload the new certificate reflecting the changes.</p> </div> <hr/>
IdP entity ID	<p>The IdP's entity ID, for example: <code>http://www.example.com/saml-idp/xxx/metadata/</code></p> <p>Note: This option is only available when the <i>Type</i> is <i>Custom</i>.</p>

IdP single sign-on URL	The IdP's login URL, for example: <code>http://www.example.com/saml-idp/xxx/login/</code> Note: This option is only available when the <i>Type</i> is <i>Custom</i> .
IdP single logout URL	The IdP's logout URL, for example: <code>http://www.example.com/saml-idp/xxx/logout/</code> Note: This option is only available when the <i>Type</i> is <i>Custom</i> .
Additional Saml Attributes FortiPAM looks for the attributes to verify authentication attempts. Configure your IdP to include the attributes in the SAML attribute statement.	
Attribute used to identify users	Enter the SAML attribute used to identify the users.
Attribute used to identify groups	Enter the SAML attribute used to identify the groups.
AD FS claim	Enable AD FS claim. Note: This option is disabled by default.
User claim type	From the dropdown, select a user claim type (default = User Principal Name).
Group claim type	From the dropdown, select a group claim type (default = User Group).

3. In the *Review* tab, verify the information you entered and click *Submit* to create the SAML SSO server.



Use the pen icon to edit tabs.



Alternatively, use the CLI commands to configure an IdP.

CLI configuration to set up a SAML IdP - example:

```
config user saml
  edit <SAML Name>
    set entity-id "http://<PAM_VIP>/saml/metadata/"
    set single-sign-on-url "https://<PAM_VIP>/XX/YY/ZZ/saml/login/"
    set single-logout-url "https://<PAM_VIP>/remote/saml/logout/"
    set idp-entity-id "http://<iDP_URL>/<idp_entity_id>"
    set idp-single-sign-on-url "https://<iDP_URL>/<sign_on_url>"
    set idp-single-logout-url "https://<iDP_URL>/<sign_out_url>"
    set idp-cert <iDP Certificate>
    set user-name "username"
    set group-name "group"
    set digest-method sha256
  next
end
config firewall access-proxy
```

```
edit "fortipam_access_proxy"
  set vip "fortipam_vip"
  config api-gateway
    edit 4
      set service samlsp
      set saml-server "fortipam-saml-ssso-server"
    next
  end
next
end
config authentication scheme
  edit "fortipam_saml_auth_scheme"
    set method saml
    set saml-server "fortipam-saml-ssso-server"
  next
end
config authentication rule
  edit "fortipam_saml_auth_rule" #Create a new rule and move it above the default
    "fortipam_auth" rule.
    set srcaddr "all"
    set dstaddr "saml_auth_addr"
    set ip-based disable
    set active-auth-method "fortipam_saml_auth_scheme"
    set web-auth-cookie enable
  next
  edit "fortipam_auth"
    set srcaddr "all"
    set ip-based disable
    set active-auth-method "fortipam_auth_scheme"
    set web-auth-cookie enable
  next
end
```

CLI configuration to enable SAML authentication on the login page - example

```
config system global
  set saml-authentication enable
end
```

To log in to FortiPAM as a SAML user:

1. On the login page, from the *Local* dropdown, select *SAML*.
2. Select *Continue* to open the SAML login page.
3. Enter the username and password to log in to FortiPAM.

Auto provision rules

Auto Provision Rules in *User Management* displays a list of auto provision rules for remote users.

Based on the predefined auto provision rules, remote users can be auto provisioned upon their first successful login without requiring the manual creation of a user in the system prior to login:

- You create an auto provision rule for remote users (LDAP, RADIUS, or SAML).
- The user is created automatically on the first successful login.

FortiPAM allows you to automatically sync up users based on group membership without limiting the authentication protocol (LDAP, RADIUS, or SAML).

The auto provision rule includes information about the remote user group and users' role (access profile) on auto provision. The type of role depends on the user's group membership.

Based on the group, FortiPAM decides if the user can log in to FortiPAM and the type of permission the user is granted. Once the user logs in, the user is automatically created and listed in *User Management > User List*.

Name	Role	Type	Lastest Login	Status	Created By	Provision Rule
ldap_6	Standard User	Remote	2024-01-08 10:51:43	Enable	Auto Provision	Out of Sync
ldap_7	Standard User	Remote	2024-01-05 13:58:22	Enable	Auto Provision	Out of Sync
ldap_8	Standard User	Remote		Enable	Auto Provision	Out of Sync
ldap_9	Standard User	Remote	2024-01-08 11:11:55	Enable	Auto Provision	Out of Sync
ldap_12	Standard User	Remote	2024-01-08 11:15:57	Enable	Manual Creation	
ldap_14	Standard User	Remote	2024-01-08 11:21:55	Enable	Manual Creation	
ldap_15	Standard User	Remote	2024-01-08 11:24:44	Enable	Manual Creation	
ldap_16	Standard User	Remote	2024-01-08 11:35:07	Enable	Manual Creation	
ldap_18	Standard User	Remote	2024-01-08 11:50:13	Enable	Auto Provision	Out of Sync
ldap_19	Standard User	Remote	2024-01-08 11:51:36	Enable	Auto Provision	Out of Sync
ldap_21	Standard User	Remote	2024-02-28 14:09:54	Enable	Auto Provision	ldap_grp2_std
ldap_24	Standard User	Remote	2024-01-11 12:02:29	Enable	Auto Provision	Out of Sync
ldap_25	Standard User	Remote	2024-01-11 12:08:27	Enable	Auto Provision	Out of Sync
m1	Standard User	Local		Enable	Manual Creation	
m2	Standard User	Local		Enable	Manual Creation	
m3	Standard User	Local		Enable	Manual Creation	
pam15_rad2	Standard User	Remote	2024-02-28 14:12:27	Enable	Auto Provision	radius_grp1
role_audit	Standard User	Local		Enable	Manual Creation	



The order of the rules impacts the login matching. First, the rule is matched from top to bottom.



The rules can be reordered by dragging a rule up/down from the left-most row.



Disabling or deleting a rule, or changing the *From Remote Group* setting for a rule results in users becoming out-of-sync, which means the current user might not match any rule until the next successful login.



Out-of-sync users do not occupy license seats.

For each auto provision rule, the following columns are displayed by default:

- *Name*
- *Status*
- *Description*

- *As Role*
- *From Remote Group*

+	Create	🔍 Search				
<input type="checkbox"/>	Name	Status	Description	As Role	From Remote Group	
<input type="checkbox"/>	rule_1	Enabled		Standard User	test_user_grp	

The *Auto Provision Rules* tab contains the following options:

Create	Select to create a new auto provision rule. See Creating an auto provision rule on page 263 .
Search	Enter a search term in the search field, then hit Enter to search the auto provision rules list. To narrow down your search, see Column filter .
Edit	Select to edit the selected auto provision rule.
Enable/Disable	Select to enable/disable the selected auto provision rule.
Delete	Select to delete the selected auto provision rule.
List Provisioned Users	Select to see the list of provisioned users in a new window for the selected auto provision rule.

To set up auto provisioning rule using the CLI, see [Setting up remote user auto provisioning using the CLI on page 265](#).

Creating an auto provision rule

To create an auto provision rule:

1. Go to *User Management > Auto Provision Rules*.
2. In the auto provision rules list, select *Create*.
The *New Auto-provision Rule* window opens.

3. Enter the following information:

Name	The name of the auto provision rule.
Status	Enable/disable the auto provision rule (default = enable).

From Remote Group

From the dropdown, select the remote user group from where to auto provision users.

To create a new remote group:

1. Select +.
The *Create New User Group* window opens.
2. Follow the steps in [Creating a remote user group](#), starting step 4 to create a new remote user group.



Use the search bar to look up a remote user group.

As Role

From the dropdown, select a role (access profile) that is assigned to the user on successful login.

To create a new user role:

1. Select +.
The *New User Role* window opens.
2. Follow the steps in *To create a role* in [Role on page 243](#), to create a new user role.



Use the search bar to look up a user role.

Description

Optionally, enter a description about the auto provision rule.

Restricted Access**Login Schedule**

Enable, and from the dropdown, select a login schedule.
This is the schedule when auto provisioned users are allowed to log in.
Note: The option is disabled by default.



Use the search bar to look up a schedule.

See [Schedule on page 267](#).

Trust Host IPv4

Enable, and from the dropdown, select trusted IPv4 addresses users use to connect to FortiPAM.
Note: The option is disabled by default.



Use + button to add a new IPv4 address and x to delete an added IPv4 address.

4. Click *Submit*.

Setting up remote user auto provisioning using the CLI

To set up remote user auto provisioning:

1. In the CLI console, enter the following commands to configure a user group:

```
config user group
edit "test_user_grp"
set member "test_ldap_server" #LDAP server set as the member
config match
edit 1
set server-name "test_ldap_server"
set group-name "cn=PAM_Group,cn=users,dc=fortipam,dc=ca"
next
end
next
end
```

2. In the CLI console, enter the following commands to configure an auto provision rule:

```
config user auto-provision-rule
edit "test_rule"
set status enable
set remote-group "test_user_grp" #user group created in step 1
set accprofile "pam_standard_user" #user role
next
end
```

When a user from the `test_user_grp` user group logs in to FortiPAM, the user is automatically created with the *Standard User* role and listed in *User Management > User List*.

RADIUS servers

RADIUS servers can be configured in *User Management*.

The RADIUS servers store users' information including credentials and some attributes. This information can authenticate FortiPAM remote users and provide groups for authorization.

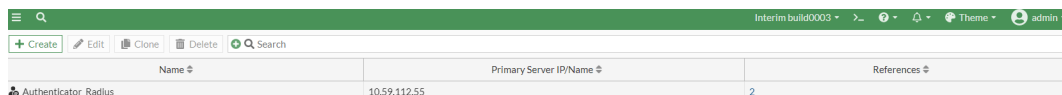

Name	Primary Server IP/Name	References
Authenticator_Radius	10.59.112.55	2

The *Radius servers* tab contains the following options:

Create	Select to create a new RADIUS server.
Edit	Select to edit the selected RADIUS server.
Clone	Select to clone the selected RADIUS server.
Delete	Select to delete the selected RADIUS servers.

Search Enter a search term in the search field, then hit **Enter** to search the RADIUS server list. To narrow down your search, see [Column filter](#).

To create a RADIUS server:

1. Go to *User Management > Radius Servers*, and select *Create*. The *New RADIUS Server* wizard opens.

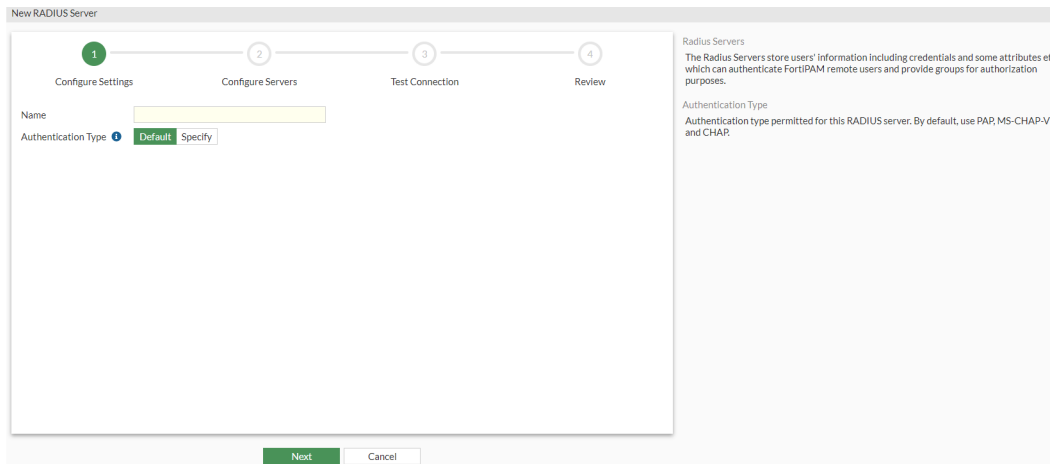

2. Enter the following information, and click *Next* after each tab:

Configure Settings

Name	The name of the RADIUS server.
Authentication Type	Select either <i>Default</i> or <i>Specify</i> . If <i>Specify</i> is selected, from the dropdown, select from the following authentication types: <ul style="list-style-type: none"> • <i>CHAP</i>: Challenge Handshake Authentication Protocol. • <i>MS-CHAP</i>: Microsoft Challenge Handshake Authentication Protocol. • <i>MS-CHAP-V2</i>: Microsoft Challenge Handshake Authentication Protocol version 2. • <i>PAP</i>: Password Authentication Protocol.

Configure Servers

Primary Server	The access request is always be sent to the primary server first. If the request is denied with an <code>Access-Reject</code> , then the user authentication fails.
IP/Name	The IP address or the FQDN.
Secret	The pre-shared passphrase used to access the RADIUS server.
Secondary Server	If there is no response from the primary server, the access request is sent to the secondary server.
IP/Name	The IP address or the FQDN.
Secret	The pre-shared passphrase used to access the RADIUS server.

3. Click *Test connection* to test the connection to the RADIUS server.
If the credentials to the server are valid, it shows *Successful*.
4. In the *Review* tab, verify the information you entered and click *Submit* to create the RADIUS server.



Use the pen icon to edit tabs.



Alternatively, use the CLI commands to create RADIUS servers.

CLI configuration to set up a RADIUS server - example:

```

config user radius
  edit <radius_server_name>
    set server <server_ip>
    set secret <secret>
  next
end
config authentication scheme
  edit "fortipam_auth_scheme"
    set method form
    set user-database "local-admin-db" <radius_server_name>
  next
end
    
```

Setting up RADIUS authentication includes the following steps:

1. Configure the RADIUS server. [Configuring a RADIUS server](#).
2. Adding the RADIUS server to a user group. [User groups on page 234](#).
3. Configuring a RADIUS user. [Creating a user on page 218](#).

Schedule

Schedule can be configured in *User Management*.

Set up a schedule to configure when the users can connect to FortiPAM.

Name	Days/Members	Start	End	Ref
Recurring				
always	Sunday Monday Tuesday Wednesday			2
default-darpp-optimize	Sunday Monday Tuesday Wednesday	01:00:00	01:30:00	0
none	None			0

The *Schedule* tab contains the following options:

Create	Select to create a new schedule.
Edit	Select to edit the selected schedule.
Clone	Select to clone the selected schedule.
Delete	Select to delete the selected schedules.
Search	Enter a search term in the search field, then hit Enter to search the schedule list.

To create a schedule:

1. Go to *User Management > Schedule*.
2. From the *Create* dropdown, select *Schedule*.
The *New Schedule* window opens.

The screenshot shows a 'New Schedule' dialog box with the following elements:

- Type:** Recurring (selected), One Time
- Name:** [Empty text field]
- Color:** [Color selection area] Change
- Days:** Monday, Tuesday, Wednesday, Thursday, Friday, Saturday, Sunday
- All day:**
- Start Time:** 12:00 AM
- Stop Time:** 12:00 AM
- Buttons:** OK, Cancel

3. In the *New Schedule* window, enter the following information:

Type	Select either <i>Recurring</i> or <i>One Time</i> .
Name	The name of the schedule.
Color	Select <i>Change</i> and then select a color.
Days	Select the days of the week when the schedule applies. Note: This option is only available when the <i>Type</i> is <i>Recurring</i> .
All day	Enable to apply the schedule all day. Note: This option is only available when the <i>Type</i> is <i>Recurring</i> .
Start Date	Enter the start date and time. Alternatively, select the calendar icon and then select a date. Similarly, select the clock icon and then select a time. Note: This option is only available when the <i>Type</i> is <i>One Time</i> .
Start Time	Enter the start time. Alternatively, select the clock icon and then select a start time. Note: This option is only available when the <i>Type</i> is <i>Recurring</i> and <i>All day</i> is disabled.
End Date	Enter the end date and time. Alternatively, select the calendar icon and then select a date. Similarly, select the clock icon and then select a time. Note: This option is only available when the <i>Type</i> is <i>One Time</i> .
Stop Time	Enter the stop time. Alternatively, select the clock icon and then select a stop time.  If the stop time is set earlier than the start time, the stop time is the same time the next day. Note: This option is only available when <i>Type</i> is <i>Recurring</i> and <i>All day</i> is disabled.
Pre-expiration event log	Select to create an event log <i>Number of days</i> before the <i>End Date</i> . Note: This option is only available when the <i>Type</i> is <i>One Time</i> .
Number of days before	Enter the number of days (1 - 100, default = 3). Note: This option is only available when the <i>Type</i> is <i>One Time</i> and <i>Pre-expiration event log</i> is enabled.



4. Click *OK*.

To create a schedule group:

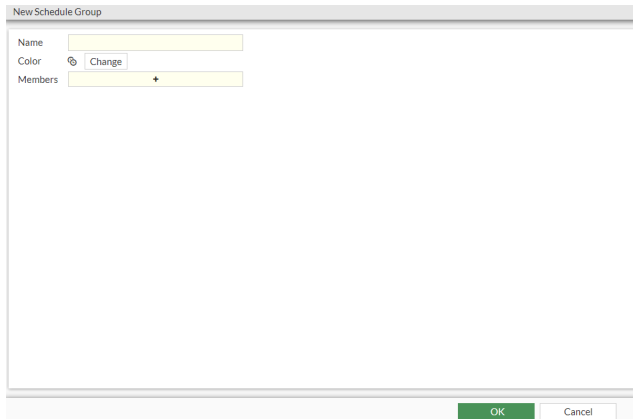
1. Go to *User Management > Schedule*.
2. From the *Create* dropdown, select *Schedule Group*.
The *New Schedule Group* window opens.



3. In the *New Schedule* window, enter the following information:

Name	The name of the schedule group.
Color	Select <i>Change</i> and then select a color.
Members	From the dropdown, select +, and in <i>Select Entries</i> , select members. If a new schedule is required, select <i>Create</i> then select the type of schedule to create a new schedule.
	Use the search bar to look for members.
	Use the pen icon next to a schedule to edit the schedule.

4. Click *Close*
5. Click *OK*.

FortiTokens

Go to *User Management > FortiTokens* to view a list of configured FortiTokens.



To access the *FortiTokens* page, you require *Read* or higher permission to *User Groups*, *Ldap Servers*, *Saml Single Sign-On*, and *Radius Servers*. See [Role on page 243](#).

For each FortiToken; type, serial number, status, user, drift, and comments are displayed by default.



To add the *License* column, click *Configure Table* when hovering over table headers, select *License*, and click *Apply*.



By default, two FortiTokens are available.

Type	Serial Number	Status	User	Drift	Comments
Mobile Token	FTKMOB23F364DDEE	Available		0	
Mobile Token	FTKMOB239B685F9	Available		0	



The following information is shown on the *FortiTokens* tab:

Create New	Create a new FortiToken.
Edit	Edit the selected FortiToken.
Delete	Delete the selected FortiToken(s).
Activate	Activate the selected FortiToken(s).
Provision	Provision the selected FortiToken(s).
Refresh	Refresh FortiToken(s).
Search	Search the FortiToken list.

To add FortiTokens:

1. Go to *User Management > FortiTokens*, and select *Create*.
The *New FortiToken* window opens.

2. Enter the following information:

Type	The token type: <ul style="list-style-type: none"> • <i>Hard Token</i> • <i>Mobile Token</i>
Comments	Optionally, enter comments about the token. Note: This option is only available when the <i>Type</i> is <i>Hard Token</i> .
Serial Number	The FortiToken serial number. <hr/>  To add multiple FortiTokens, select + and enter a new serial number. <hr/> Note: This option is only available when the <i>Type</i> is <i>Hard Token</i> .
Activation Code	The activation code. Note: This option is only available when the <i>Type</i> is <i>Mobile Token</i> .
Import	Select the option to import multiple tokens by selecting one of the following and clicking <i>OK</i> : <ul style="list-style-type: none"> • <i>Serial Number File</i>: Select <i>Upload</i> to load a CSV file that contains token serial numbers. <hr/>  FortiToken devices have a serial number barcode on the m used to create the import file. <hr/> <ul style="list-style-type: none"> • <i>Seed File</i>: Select <i>Upload</i> to load a CSV file that contains token serial numbers, encrypted seeds, and IV values. Note: This option is only available when the <i>Type</i> is <i>Hard Token</i> .

3. Click *OK*.**Monitoring FortiTokens**

You can also view the list of FortiTokens, their status, token clock drift, and which user they are assigned to from the FortiToken list found at *User Management > FortiTokens*.

Monitoring

Go to *Monitoring* to access the following tabs:

- [User monitor on page 273](#)
- [Active sessions on page 273](#)

User monitor

The *User Monitor* tab in *Monitoring* displays all the logged-in users along with information such as their role, logged-in IP address, the duration they have logged in for, traffic volume, timestamp of when they logged in last, and the location from where they have logged in. It is a helpful tool for monitoring the overall activities of the users on FortiPAM. For example, if the administrator sees an unusual amount of traffic from a specific user. It could indicate that a risky operation is being performed, and the administrator may deauthenticate the user if the administrator deems the user is a malicious actor.

For every login; username, role, IP address, duration, traffic volume, the last login date and time, and location are displayed.

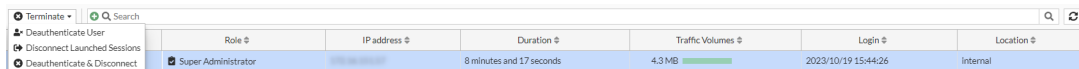

Role	IP Address	Duration	Traffic Volumes	Login	Location
Super Administrator	192.168.1.1	8 minutes and 17 seconds	4.3 MB	2023/10/19 15:44:26	Internal

The *User Monitor* tab contains the following options:

Terminate	From the dropdown, select from the following options for a selected user: <ul style="list-style-type: none">• <i>Deauthenticate User</i>: Kick out a logged in FortiPAM user.• <i>Disconnect Launched Sessions</i>: Terminate all the launched secret sessions associated with the user.• <i>Deauthenticate & Disconnect</i>: Kick out a logged in FortiPAM user and all the launched secret sessions associated with the user.
Search	Enter a search term in the search field, then hit <code>Enter</code> to search the user monitor list. To narrow down your search, see Column filter .
Refresh	To refresh the contents, click the refresh icon.

Active sessions

The *Active Sessions* tab in *Monitoring* provides a way to oversee activities of launched secrets from FortiPAM. The page lists out all the launched secrets with information such as source IP: Port, destination IP: Port, the application that is launched and username, etc.

Additionally, a *Disconnect* button is available when you select a secret session. Using the *Disconnect* button, you can terminate the selected launched secret session. This monitor is especially powerful in situations where there is malicious

activity being conducted by a user because the administrator will be able to terminate the session right away with the *Disconnect* button to protect the integrity of the secret.



Disconnecting native non-proxy sessions is currently not supported.

On the top, the following widget is displayed:

- *Username*: displays the total count of the users using secrets.

For every session, the following columns are displayed by default:

- *Session ID*
- *Username*
- *Account Name*
- *Token ID*
- *Source*
- *Source Port*
- *Source Location*
- *Destination*: The actual target server IP address.
- *Destination Port*
- *Gateway*: The gateway IP address.
- *Gateway Port*
- *Gateway Name*: The gateway name.
- *Application*
- *Duration (sec)*

Session ID	Username	Account Name	Token ID	Source	Source Port	Source Location	Destination	Destination Port	Gateway	Gateway Port	Gateway Name	Application	Duration(sec)
39063367	admin	N/A	3410516638		54286	internal		443	N/A	N/A	N/A	SSH over Web	5

The *Active Sessions* tab contains the following options:

Group by	Select to group the active sessions by either username or secret.
Refresh	To refresh the contents, click the refresh icon.
Search	Enter a search term in the search field, then hit <code>Enter</code> to search the active sessions list. To narrow down your search, see Column filter .

For an active secret session, you can terminate the session by clicking *Disconnect the current secret session* as you live stream the session.

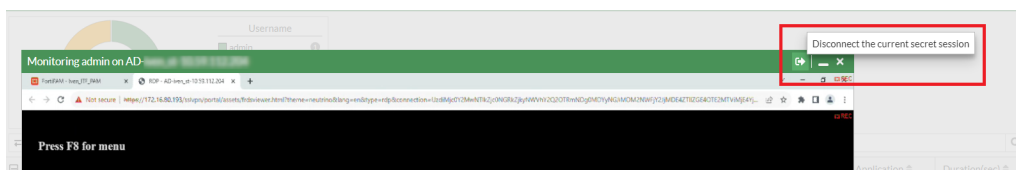

For information on over-the-shoulder monitoring, see [Over-the-shoulder monitoring \(Live recording\)](#) on page 275.

Over-the-shoulder monitoring (Live recording)

FortiPAM allows administrators to monitor the user session and actions in real-time.

Prerequisites:

- *Fortinet Privileged Access Agent 7.2.3* or above is required to support over-the-shoulder monitoring.
- When you launch a secret with *Session Recording* enabled, and given that *Live Recording* is enabled in the *Advanced* tab in *System > Settings*, you can monitor the user session in real-time.



To ensure seamless real-time video recording and transmission to FortiPAM, consider the following system resource guidelines for launching multiple concurrent sessions:

- CPU: 8 logical processors
- Memory: 16 GB

To monitor the user secret session in real-time:

1. Go to *Monitoring > Active Sessions*.
2. Select the secret session and click *Monitor*.



Secret sessions with a red video recording icon are ready to be live-streamed.

Session ID	Username	Account Name	Token ID	Source	Source Port	Source Location	Destination	Destination Port	Application	Duration(sec)
10.59.112.204.RDP.lvesh_st	lvesh	lvesh_st	1578684303	Internal	51617	Internal	3389		RDP-over-Web	21
138725657	ftal	ftal	1401868579	Internal	53909	Internal	3389		Remote desktop	2707

A new window opens. The window displays user activity in real-time.

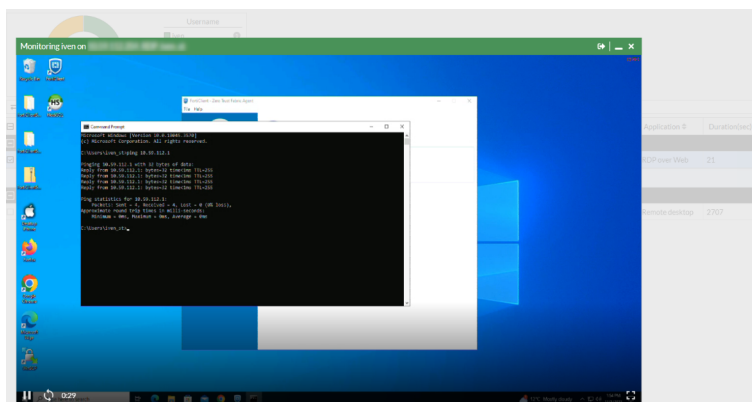



You can terminate an active session by clicking *Disconnect the current secret session* icon on the top-right as you live stream the session.

Log & report

Logging and reporting are valuable components to help you understand what is happening on your network and to inform you about network activities, such as system and user events.

Reports show the recorded activity in a more readable format. A report gathers all the log information that it needs, then presents it in a graphical format with a customizable design and automatically generated charts showing what is happening on the network.

Go to *Log & Report* to access the following tabs:

- [Secret on page 277](#)
- [Events on page 281](#)
- [ZTNA on page 284](#)
- [SSH on page 285](#)
- [Antivirus on page 287](#)
- [Date leak prevention on page 288](#)
- [Reports on page 288](#)
- [Log settings on page 295](#)
- [Email alert settings on page 302](#)
- [Debug settings on page 304](#)

Secret

Go to *Secret* in *Log & Report* to see logs related to the following:

- [Secret on page 278](#)
- [Clear Text on page 279](#)
- [Check-outs and Check-ins on page 279](#)
- [Password Changes on page 279](#)
- [Secret Video on page 280](#)
- [Secret Request on page 280](#)
- [Job on page 281](#)
- [Service Account on page 281](#)

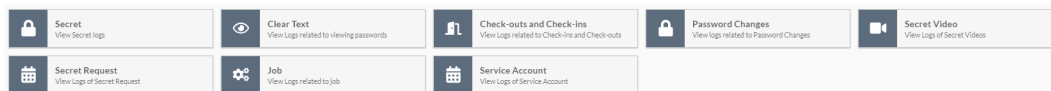

The following options are available in the tabs:

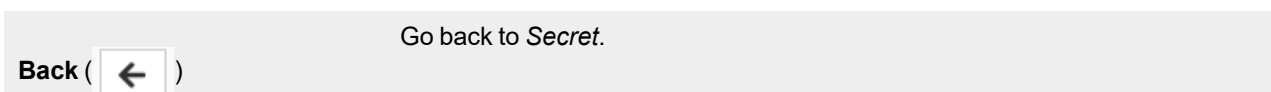

Export

From the *Export* dropdown, select to export the logs in the following three formats:

- *JSON*: Export the selected secret session log to your computer as a JSON file named as *secret-xyz-YYYY_MM_DD.json*
- *CSV*: Export the selected secret session log to your computer as a CSV file named as *secret-xyz-YYYY_MM_DD.csv*
- *TEXT*: Export the selected secret session log to your computer as a text file named as *secret-xyz-YYYY_MM_DD.txt*

Log location

Select a source from where to retrieve logs:

- *Disk* (default) (FortiPAM)
- *FortiAnalyzer*

See [FortiAnalyzer logging on page 320](#) for setting up FortiAnalyzer as the remote logging server.

Time frame

From the dropdown, select from the following time filters:

- *5 minutes*
- *1 hour*
- *24 hours*
- *7 days*
- *Custom*
- *View All*

Custom filter

1. From the dropdown, select *Custom*.
2. In the window that opens, you can set combinations of *=*, *Range*, *<=*, *>=*, and *NOT*.
3. Enter a date and time.
4. Click *Apply*.

For example, to create a range filter that filters and displays all the logs between 8:00 AM on 10th October, 2023 to 1:00 PM on 12th October 2023, we set up a filter that looks like the following:

Refresh

To refresh the contents, click the refresh icon.

Details

Select to see details for the selected log entry.

Search

Enter a search term in the search field, then hit *Enter* to search the secret video list. To narrow down your search, see [Column filter](#).

Secret

Selecting *Secret* opens all the secret logs. Different subcategories of secret logs are displayed when you click on a secret log.

Date/Time	Token Id	Secret name	User	Account	Operation	Action	Launcher	Application Type	Source IP	Secret Address	Destination IP	Gateway	Message
2024/03/25 10:29:42	3028636477	test_video	admin		✖ Fetching metadata	✔ Accepted	🖱 Web SSH	🔒 SSH					PAM token is fetched.
2024/03/25 10:29:40	3028636477	test_video	admin		🚀 Launched secret	✔ Accepted	🖱 Web SSH	🔒 SSH					PAM token is allocated.
2024/03/25 10:29:34	3028177725	test_secret	admin		🚀 Launched secret	✔ Accepted	🖱 PuTTY	🔒 SSH					PAM token is allocated.

where:

- **Secret Address:** The IP address or FQDN of the actual target server.
- **Gateway:** The gateway name for the secret.
- **Destination IP:** The next hop IP address. If the next hop is FortiPAM, this is the IP address of FortiPAM. If the next hop is the actual target server, this is the IP address of the actual target server. If the next hop is a gateway, this is the IP address of the gateway.

Clear Text

Selecting *Clear Text* shows logs related to viewing passwords. This category of the secret log shows all the information related to the launching of a secret, uploading of a video, termination of a launched session, and status of a FortiPAM token.

Date/Time	Secret name	User	Account	Operation	Message	Agent	Action
2024/02/16 14:15:02	Windows_AD_200 pwd_chg_ldaps186	admin	pwd_chg_ldaps186	👁 View credential	Clear text view allowed.	GUI	✔ Response
2024/02/16 13:38:59	Windows_AD_200 - Robert	admin	robert	👁 View credential	Clear text view allowed.	GUI	✔ Response
2024/02/16 13:33:33	Windows_AD_200 pam31_ldap1111	admin	pam31_ldap	👁 View credential	Clear text view allowed.	GUI	✔ Response
2024/02/15 14:39:36	Windows_AD_200 pam31_ldap	admin	pam31_ldap	👁 View credential	Clear text view allowed.	GUI	✔ Response
2024/02/15 14:31:36	hhkjhhkhk	admin	robert_ldap4	👁 View credential	Clear text view allowed.	GUI	✔ Response
2024/02/15 14:31:33	hhkjhhkhk	admin	robert_ldap4	👁 View credential	Clear text view allowed.	GUI	✔ Response
2024/02/15 14:30:47	hhkjhhkhk	admin	robert_ldap4	👁 View credential	Clear text view allowed.	GUI	✔ Response
2024/02/13 21:58:24	Windows_AD_200 pam31_ldap	admin	pam31_ldap	👁 View credential	Clear text view allowed.	GUI	✔ Response
2024/02/13 21:43:49	Windows_AD_200 robert_ldap2	admin	robert_ldap2	👁 View credential	Clear text view allowed.	GUI	✔ Response
2024/02/13 21:43:42	Windows_AD_200 robert_ldap3	admin	robert_ldap3	👁 View credential	Clear text view allowed.	GUI	✔ Response
2024/02/13 21:42:59	Windows_AD_200 robert_ldap3	admin	robert_ldap3	👁 View credential	Clear text view allowed.	GUI	✔ Response
2024/02/13 21:41:43	Windows_AD_200 robert_ldap2	admin	robert_ldap2	👁 View credential	Clear text view allowed.	GUI	✔ Response
2024/02/12 18:35:03	Windows_AD_200 pam31_ldap	admin	pam31_ldap	👁 View credential	Clear text view allowed.	GUI	✔ Response
2024/02/12 18:28:40	Windows_AD_200 robert_ldap2	admin	robert_ldap2	👁 View credential	Clear text view allowed.	GUI	✔ Response
2024/02/12 18:26:16	Windows_AD_200 robert_ldap2	admin	robert_ldap2	👁 View credential	Clear text view allowed.	GUI	✔ Response
2024/02/12 18:26:07	Windows_AD_200 pam31_ldap	admin	pam31_ldap	👁 View credential	Clear text view allowed.	GUI	✔ Response
2024/02/12 18:25:47	Windows_AD_200 pam14_ldap	admin	pam14_ldap	👁 View credential	Clear text view allowed.	GUI	✔ Response

Check-outs and Check-ins

Selecting *Check-outs and Check-ins* shows logs related to password check-ins and check-outs. It displays all the information related to secret check-out and check-in.

Date/Time	Secret name	User	Account	Operation	Message	Action	Agent
2024/02/16 17:55:48	test	admin		📄 Checkout	Successfully checkout secret.	✔ Response	GUI

Password Changes

Selecting *Password Changers* shows logs related to password changers. It displays all the information about when a password changer is triggered on a secret. It indicates whether the operation is successful and who initiated the operation. Operations such as password verification or change of password are recorded here.

Date/Time	Secret name	User	Account	Password Changer	Operation	Message	Action	Secret Address	Secret Port	Destination IP	Destination Port	Gateway
2024/03/25 11:12:47	test_password_changer	admin	admin	ESXi Password	Password Changed	Password change failed(Connection failure Connection timed out).	Connection Error		22		22	

For some column descriptions, see [Secret](#) on page 278.

Secret Video

Selecting *Secret Video* shows logs related to secret videos. This category of the secret log shows all the videos of launched secrets from FortiPAM. It is helpful to assist in auditing a user's behavior on the secret, ensuring that no malicious activity is performed.

Date/Time	Token Id	Secret name	User	Account	Operation	Action	Launcher	Application Type	Source IP	Secret Address	Destination IP	Gateway	Message
2024/03/25 10:29:...	3028636477	test_video	admin		Video upload start	Video upload start	Web SSH	SSH					Uploading.

To view a recorded video of a launched secret:

1. Select the log with the operation labelled as *Video upload finished*, then click the *Details* button located at the right of the menu.

Alternatively, double-click the log labelled as *Video upload finished*.

The video player opens, and the secret video is automatically played.

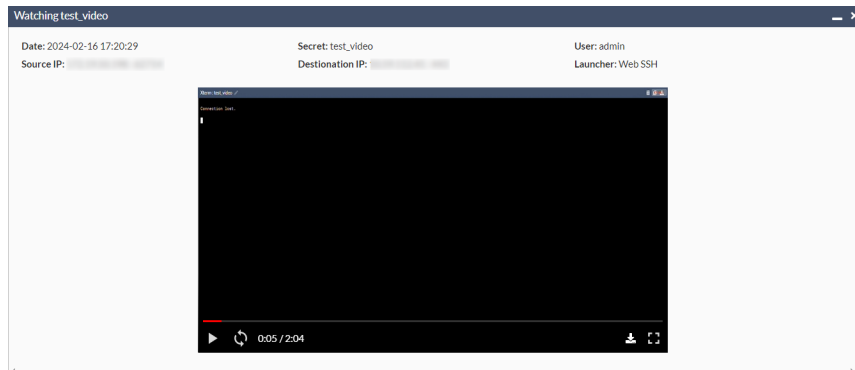

To download a recorded video of a launched secret:

1. Select the log with the operation labelled as *Video upload finished*, then click the *Details* button located at the right of the menu.

Alternatively, double-click the log labelled as *Video upload finished*.

2. From the window that opens, select the download icon (📄) to save the secret video on your computer in WebM format.

Secret Request

Selecting *Secret Request* shows logs related to secret requests. This category of the secret log shows all the information related to a secret that requires secret approval. It indicates when a request is submitted for a secret or when a request is approved or denied.

Date/Time	Secret name	User	Operation	Start Time	Expired Time	Message	Action
2024/02/20 13:00:40	test	admin	Approved access	2024-02-20 13:00:00	2024-02-20 14:00:00	Request has been changed.	Response
2024/02/20 13:00:30	test	admin	Request access	2024-02-20 13:00:00	2024-02-20 14:00:00	Created secret request.	Pass

Job

Selecting *Job* shows all logs related to jobs. This category of secret log keeps track of all the events related to an execution of a job on a secret. This includes the job name, the user who initiated the job, the type of the job, and whether the job is executed successfully.

Date/Time	Secret name	Job	Job Type	User	Account	Operation	Message	Action	Destination IP	Destination Port
-----------	-------------	-----	----------	------	---------	-----------	---------	--------	----------------	------------------

Service Account

Selecting *Service Account* shows all the logs related to service accounts. This category of the secret log shows information related to updating credentials related to a service account.

Date/Time	Secret name	User	Account	Updater	Updater Type	Secret Address	Operation	Action	Message	Agent
-----------	-------------	------	---------	---------	--------------	----------------	-----------	--------	---------	-------

Events

The following two tabs are available in *Events*:

- **Summary**

The *Summary* tab displays the top five most frequent events in each type of event log and a line chart to show aggregated events by each severity level. Clicking on a peak in the line chart will display the specific event count for the selected severity level.

There is an option for the line chart to change the time filter in which the events occurred, from 5 minutes to 7 days.

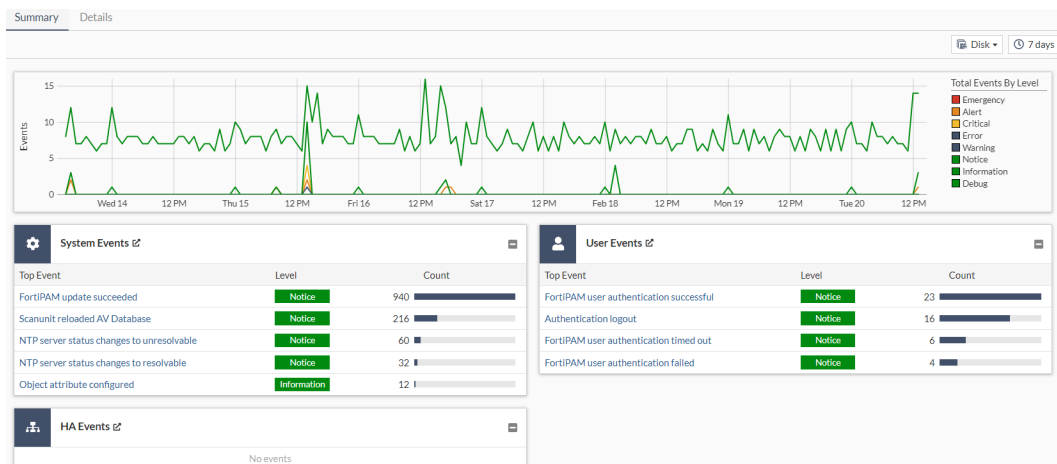

The *System Events* log contains events such as:

- Upgrade and downgrade of the system
- Change of system configuration, such as timezone and FortiPAM recording settings
- Deletion of outdated video files
- Report generation
- Reload of AntiVirus database

And more.

The *User Events* log contains events such as:

- IP address and time when the user logs in or logs out
- Login failure reason
- User login as a normal user or API user

And more.

The *HA Events* log contains events such as:

- Change in HA clusters
- Synchronization status with the HA peers

And more.

The following options and widgets are available in the *Summary* tab:

Log location	Logs sourced from the FortiPAM disk only.
Time frame	From the dropdown, select from the following time filters: <ul style="list-style-type: none"> • 5 minutes • 1 hour • 24 hours • 7 days
System Events	Top system events by count.
User Events	Top user events by count.
HA Events	Top HA events by count.



In *System Events*, *User Events*, or *HA Events* widgets, select an event to open the corresponding details tab with all the logs for the event listed in a table.

- *Details*

The tab displays the related information of each log for a specific event type. The event type can be toggled with the event type dropdown located right of the search bar. Different filters can be added, such as date/time to filter logs in a time range.

Date/Time	Level	User	Message	Description
24 seconds ago	Success		FortiPAM update now fsci=yes from 173.243.140.6:443	FortiPAM update succeeded
17 minutes ago	Success		FortiPAM update now fsci=yes from 173.243.140.6:443	FortiPAM update succeeded
28 minutes ago	Success		FortiPAM scheduled update fcnl=yes fdnl=yes fsci=yes cidb(0.00000) from 173.243.140.6:443	FortiPAM update succeeded
33 minutes ago	Success		FortiPAM update now fsci=yes from 173.243.140.6:443	FortiPAM update succeeded
38 minutes ago	Success	ntp_daemon	The IPv4 ntp server, ntp1.fortiguard.com(208.91.112.63), is determined resolvable at Tue ...	NTP server status changes to resolvable
50 minutes ago	Success		FortiPAM update now fsci=yes from 173.243.140.6:443	FortiPAM update succeeded
58 minutes ago	Success		scanunit=manager pid=1548 cause=signal AV database reload requested 1 times by up...	Scanunit reloaded AV Database
58 minutes ago	Success		FortiPAM scheduled update fcnl=yes fdnl=yes fsci=yes virdb(92.01754) etdb(92.01754) ...	FortiPAM update succeeded
Hour ago	Success	ntp_daemon	The IPv4 ntp server, ntp1.fortiguard.com(unresolved), is determined unresolvable at Tue ...	NTP server status changes to unresolvable
Hour ago	Success	ntp_daemon	The IPv4 ntp server, ntp2.fortiguard.com(unresolved), is determined unresolvable at Tue ...	NTP server status changes to unresolvable
Hour ago	Success		FortiPAM update now fsci=yes from 173.243.140.6:443	FortiPAM update succeeded
Hour ago	Success		FortiPAM update now fsci=yes from 173.243.140.6:443	FortiPAM update succeeded
Hour ago	Success		scanunit=manager pid=1548 cause=signal AV database reload requested 1 times by up...	Scanunit reloaded AV Database
Hour ago	Success		FortiPAM scheduled update fcnl=yes fdnl=yes fsci=yes virdb(92.01753) etdb(92.01753) ...	FortiPAM update succeeded
Hour ago	Success		FortiPAM update now fsci=yes from 173.243.140.6:443	FortiPAM update succeeded
Hour ago	Warning	admin	Configuration is changed in the admin session	Configuration changed
Hour ago	Success	admin	Add secret.request 1	Object attribute configured
Hour ago	Success	admin	Edit secret.database 2	Object attribute configured
Hour ago	Success	admin	Add secret.approval-profile test_profile	Object attribute configured
Hour ago	Success		FortiPAM update now fsci=yes from 173.243.140.6:443	FortiPAM update succeeded
Hour ago	Success		scanunit=manager pid=1548 cause=signal AV database reload requested 1 times by up...	Scanunit reloaded AV Database
Hour ago	Success		FortiPAM scheduled update fcnl=yes fdnl=yes fsci=yes virdb(92.01753) etdb(92.01753) ...	FortiPAM update succeeded
2 hours ago	Success		FortiPAM update now fsci=yes from 173.243.140.6:443	FortiPAM update succeeded

The following options are available in the *Details* tab:

Refresh

To refresh the contents, click the refresh icon.

Export

From the *Export* dropdown, select to export the logs in the following three formats:

- *JSON*: Export the selected log to your computer as a JSON file
- *CSV*: Export the selected log to your computer as a CSV file
- *TEXT*: Export the selected log to your computer as a text file

+Add Filter

From the dropdown, select a filter, select or add additional details about the filter to be used and hit *Enter*.

Note: Logs can be filtered by date and time. The log viewer can be filtered with a custom range or with specific time frames.



Time frame settings for each *Log & Report* page are independent. For example, changing the time frame on the *System Events* page does not automatically change the time frame on the *User Events* and *HA Events* pages.

System Events

From the dropdown, select from the following event types to display:

- *System Events*
- *User Events*
- *HA Events*

Log location

Select a source from where to retrieve logs:

- *Disk* (default) (FortiPAM)
- *FortiAnalyzer*

Time frame

From the dropdown, select from the following time filters:

- *5 minutes*
- *1 hour*
- *24 hours*

- 7 days
- Custom
- View All

Custom filter

1. From the dropdown, select *Custom*.
2. Click the search bar.
3. Select \leq , \geq , or A-B (date and time range).
4. Depending on your selection in step 3, enter a date and time or a date and time range.
5. Hit **Enter**.

Details

Select a log entry and then select *Details* to see more information about the log.

ZTNA

Go to ZTNA in *Log & Report* to see ZTNA related logs.

The ZTNA log keeps track of ZTNA related traffics. This can include when a ZTNA rule cannot be matched, an API gateway cannot be matched, or when a secret configured with device permission fails to connect.

Date/Time	Source IP	Access Proxy	Real Server	Service	Result	ZTNA Rule
Friday	admin	fortipam_access_proxy		HTTPS	918 B / 0 B	1
Friday	admin	fortipam_access_proxy		HTTPS	231.98 kB / 0 B	1
Friday	admin	fortipam_access_proxy		HTTP	13.98 kB / 1.49 MB	1
Friday	admin	fortipam_access_proxy		HTTPS	720 B / 0 B	1
Friday	admin	fortipam_access_proxy		HTTP	22.68 kB / 10.05 kB	1
Friday	admin	fortipam_access_proxy		HTTPS	712 B / 0 B	1
Friday	admin	fortipam_access_proxy		HTTP	10.72 kB / 1.44 MB	1
Friday	admin	fortipam_access_proxy		HTTP	13.98 kB / 2.71 kB	1
Friday	admin	fortipam_access_proxy		HTTPS	704 B / 0 B	1

The following options are available in the ZTNA tab:

Refresh	To refresh the contents, click the refresh icon.
Export	From the <i>Export</i> dropdown, select to export the ZTNA logs in the following three formats: <ul style="list-style-type: none"> • <i>JSON</i>: Export the selected ZTNA log to your computer as a JSON file • <i>CSV</i>: Export the selected ZTNA log to your computer as a CSV file • <i>TEXT</i>: Export the selected ZTNA log to your computer as a text file
+Add Filter	From the dropdown, select a filter, select or add additional details about the filter to be used and hit Enter . Note: Logs can be filtered by date and time. The log viewer can be filtered with a custom range or with specific time frames.
Log location	Select a source from where to retrieve logs: <ul style="list-style-type: none"> • <i>Disk</i> (default) (FortiPAM) • <i>FortiAnalyzer</i>

Time frame From the dropdown, select from the following time filters:

- 5 minutes
- 1 hour
- 24 hours
- 7 days
- Custom
- View All

See [Custom filter on page 284](#), for an example on how to set up custom filters.

Details Select to see details for the selected log entry.

SSH

Go to *SSH* in *Log & Report* to see SSH related logs.

For each SSH log, the following columns are displayed:

- Date/time
- Severity
- Action
- Command
- Secret ID
- User
- Token Id
- Event Type
- Group
- Source Port
- Destination IP
- Destination Port
- Protocol

Date/Time	Severity	Action	Command	Secret ID	User	Token Id	Event Type	Source Port	Destination IP	Destination Port
2023/06/07 09:05:46	■ ■ ■ ■ ■	Blocked	Is	9	admin	2866139722	ssh-command	50666	172.17.219.58	22
2023/06/06 19:10:48	■ ■ ■ ■ ■	Blocked	Is	9	admin	387790			172.17.219.58	22

Selecting the *Corresponding secret* or the *Corresponding secret video* buttons when you right-click an SSH log takes you to the corresponding secret log or the secret video log, respectively.



Date/Time	Token Id	Secret name	User	Account	Message	Action	Operation	Launcher	Application Type
2023/06/07 09:05:53	2866139722	VM-58	admin	admin	Remote session ended.	Max duration Exceeded	Connection Closed		
2023/06/07 09:05:47	2866139722	VM-58	admin	admin	Uploading.	Video Start	Uploading	PuTTY	SSH
2023/06/07 09:05:41	2866139722	VM-58	admin	admin	PAM token is fetched.	Accepted	Fetching		
2023/06/07 09:05:41	2866139722	VM-58	admin	admin	PAM token is allocated.	Accepted	Start		

The SSH log keeps track of all the events related to the SSH filter profile. It contains information such as the severity of a command, the destination IP and port used to execute the command, and the action associated with the log. The action may be *Blocked*, indicating the command has been blocked from executing on the secret or *Passthrough*, representing it is allowed to execute on the secret.

The following options are available in the SSH tab:

Back ()	Go back to SSH.
Export	<p>From the <i>Export</i> dropdown, select to export the SSH logs in the following three formats:</p> <ul style="list-style-type: none"> <i>JSON</i>: Export the selected SSH log to your computer as a JSON file named as <i>secret-xyz-YYYY_MM_DD.json</i> <i>CSV</i>: Export the selected SSH log to your computer as a CSV file named as <i>secret-xyz-YYYY_MM_DD.csv</i> <i>TEXT</i>: Export the selected SSH log to your computer as a text file named as <i>secret-xyz-YYYY_MM_DD.txt</i>
Log location	<p>Select a source from where to retrieve logs:</p> <ul style="list-style-type: none"> <i>Disk</i> (default) (FortiPAM) <i>FortiAnalyzer</i>
Time frame	<p>From the dropdown, select from the following time filters:</p> <ul style="list-style-type: none"> <i>5 minutes</i> <i>1 hour</i> <i>24 hours</i> <i>7 days</i> <i>Custom</i> <p>See Custom filter on page 278 for an example on how to set up custom filters.</p> <ul style="list-style-type: none"> <i>View All</i>

Refresh	To refresh the contents, click the refresh icon.
Details	Select to see details for the selected log entry.
Search	Enter a search term in the search field, then hit <code>Enter</code> to search the secret video list. To narrow down your search, see Column filter .

Antivirus

Go to *Log & Report > Antivirus* to see logs related to antivirus.

The antivirus log records when, during the antivirus scanning process, the FortiPAM unit finds a match within the antivirus profile, which includes the presence of a virus or grayware signature.

The following options are available in the *Antivirus* tab:

Refresh	To refresh the contents, click the refresh icon.
Export	From the <i>Export</i> dropdown, select to export the antivirus logs in the following three formats: <ul style="list-style-type: none"> • <i>JSON</i>: Export the selected antivirus log to your computer as a JSON file • <i>CSV</i>: Export the selected antivirus log to your computer as a CSV file • <i>TEXT</i>: Export the selected antivirus log to your computer as a text file
+Add Filter	From the dropdown, select a filter, select or add additional details about the filter to be used and hit <code>Enter</code> . Note: Logs can be filtered by date and time. The log viewer can be filtered with a custom range or with specific time frames.
Log location	Select a source from where to retrieve logs: <ul style="list-style-type: none"> • <i>Disk</i> (default) (FortiPAM) • <i>FortiAnalyzer</i>
Time frame	From the dropdown, select from the following time filters: <ul style="list-style-type: none"> • <i>5 minutes</i> • <i>1 hour</i> • <i>24 hours</i> • <i>7 days</i> • <i>Custom</i> See Custom filter on page 284, for an example on how to set up custom filters. • <i>View All</i>
Details	Select to see details for the selected log entry.

Date leak prevention

Go to *Log & Report > Data Leak Prevention* to see logs related to DLP.

The data leak prevention (DLP) log provides valuable information about the sensitive data trying to get through to your network as well as any unwanted data trying to get into your network.

The following options are available in the *Data Leak Prevention* tab:

Refresh	To refresh the contents, click the refresh icon.
Export	From the <i>Export</i> dropdown, select to export the DLP logs in the following three formats: <ul style="list-style-type: none"> • <i>JSON</i>: Export the selected DLP log to your computer as a JSON file • <i>CSV</i>: Export the selected DLP log to your computer as a CSV file • <i>TEXT</i>: Export the selected DLP log to your computer as a text file
+Add Filter	From the dropdown, select a filter, select or add additional details about the filter to be used and hit <i>Enter</i> . Note: Logs can be filtered by date and time. The log viewer can be filtered with a custom range or with specific time frames.
Log location	Select a source from where to retrieve logs: <ul style="list-style-type: none"> • <i>Disk</i> (default) (FortiPAM) • <i>FortiAnalyzer</i>
Time frame	From the dropdown, select from the following time filters: <ul style="list-style-type: none"> • <i>5 minutes</i> • <i>1 hour</i> • <i>24 hours</i> • <i>7 days</i> • <i>Custom</i> <p>See Custom filter on page 284, for an example on how to set up custom filters.</p> <ul style="list-style-type: none"> • <i>View All</i>
Details	Select to see details for the selected log entry.

Reports

Go to *Log & Reports > Reports* to access the following:

- [General on page 289](#)
- [Secret audit on page 294](#)

General

In *General*, you can generate and view general FortiPAM reports. You can also customize the report layout and schedule the generation of reports.

The following two tabs are available in *General*:

- [Reports on page 289](#)
- [Layout & schedule on page 290](#)

Reports

Reports displays a list of audit reports generated to comply with audit requirements.

For each report entry; name, data start, data end, layout, and the size are displayed.

The screenshot shows the 'Reports' tab in the FortiPAM interface. It displays a table with columns for Name, Data Start, Data End, Layout, and Size. The table contains 21 rows of report entries, each with a checkbox on the left. The reports are scheduled daily from 2023/09/06 to 2023/09/25. The layout for all reports is 'default', and the sizes range from 136.33 KIB to 136.43 KIB.

Name	Data Start	Data End	Layout	Size
Schedule-default-2023-09-26-000100	2023/09/25	2023/09/25	default	136.43 KIB
Schedule-default-2023-09-25-000100	2023/09/24	2023/09/24	default	136.33 KIB
Schedule-default-2023-09-24-000100	2023/09/23	2023/09/23	default	136.33 KIB
Schedule-default-2023-09-23-000100	2023/09/22	2023/09/22	default	136.33 KIB
Schedule-default-2023-09-22-000100	2023/09/21	2023/09/21	default	136.33 KIB
Schedule-default-2023-09-21-000100	2023/09/20	2023/09/20	default	136.33 KIB
Schedule-default-2023-09-20-000100	2023/09/19	2023/09/19	default	136.38 KIB
Schedule-default-2023-09-19-000100	2023/09/18	2023/09/18	default	136.38 KIB
Schedule-default-2023-09-18-000100	2023/09/17	2023/09/17	default	136.33 KIB
Schedule-default-2023-09-17-000100	2023/09/16	2023/09/16	default	136.33 KIB
Schedule-default-2023-09-16-000100	2023/09/15	2023/09/15	default	136.38 KIB
Schedule-default-2023-09-15-000100	2023/09/14	2023/09/14	default	136.33 KIB
Schedule-default-2023-09-14-000100	2023/09/13	2023/09/13	default	136.43 KIB
Schedule-default-2023-09-13-000100	2023/09/12	2023/09/12	default	136.38 KIB
Schedule-default-2023-09-12-000100	2023/09/11	2023/09/11	default	136.33 KIB
Schedule-default-2023-09-11-000100	2023/09/10	2023/09/10	default	136.33 KIB
Schedule-default-2023-09-10-000100	2023/09/09	2023/09/09	default	136.33 KIB
Schedule-default-2023-09-09-000100	2023/09/08	2023/09/08	default	136.38 KIB
Schedule-default-2023-09-08-000100	2023/09/07	2023/09/07	default	136.38 KIB
Schedule-default-2023-09-07-000100	2023/09/06	2023/09/06	default	136.43 KIB

A report generated using the default layout includes:

- User Login: Top successful logins, top failed logins, and top failed logins by reason.
- System: Maintenance mode, top maintenance mode activation by user, glass breaking mode, top glass breaking mode activation by user, and HA mode.
- Secret (includes the following):
 - Secret launch success
 - Top secret launch success by secret name
 - Top secret launch success by secret name and user
 - Password change
 - Top successful password change by secret name
 - Top successful password change by secret name and user
 - Top failed password change by secret name
 - Top failed password change by secret name and reason
 - Top failed password change by secret name, user and reason
 - Password verification

- Top successful password verification by secret name
- Top successful password verification by secret name and user
- Top failed password verification by secret name
- Top failed password verification by secret name and reason
- Top failed password verification by secret name, user and reason
- Clear text view
- Top clear text view by secret name
- Top clear text view by secret name and user

The *Reports* tab contains the following options:

Generate Report	Select <i>Generate Report</i> , from the <i>Layout</i> dropdown select a report layout, and click <i>OK</i> .
	 <p>Use the search bar to look up a report layout.</p>
Search	Enter a search term in the search field, then hit <i>Enter</i> to search the reports list. To narrow down your search, see Column filter .
Refresh	To refresh the contents, click the refresh icon.

The following options are available for each of the generated report:

View	Select to view the selected report.
Download	Select to export the selected report to your computer as a pdf file.
Delete	Select to delete the selected reports.

Layout & schedule

FortiPAM allows you to customize reports to display attributes according to your preference and schedule generation of reports.

The *Layout & Schedule* tab looks like the following:

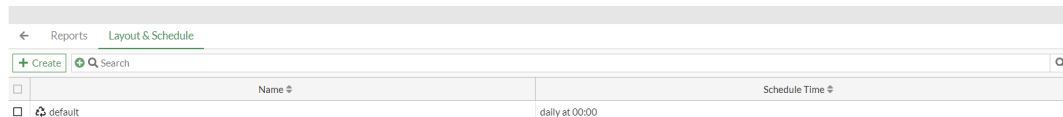

A *default* layout and schedule is available.
 The default layout and schedule generates a comprehensive report daily at 12:00 AM (midnight) with information on user login, system, and secret.
 This report is only available on FortiPAM and is not sent out as an email.

The *Layout & Schedule* tab contains the following options:

Create	Select to create a new report layout and schedule. See Creating a report layout and schedule on page 291 .
Search	Enter a search term in the search field, then hit <code>Enter</code> to search the layout and schedule list. To narrow down your search, see Column filter .

Creating a report layout and schedule

To create a report layout and schedule:

1. Go to *Log & Report > Reports* and select *General*.
2. Switch to the *Layout & Schedule* tab and select *Create*.
The *New Configure report layout* window opens.

3. To switch to either *Schedule* and *Email* tab, select the tab.

4. Enter the following information:

Name	The name of the custom report layout and schedule.
	 <p>Only alphanumeric characters are allowed.</p>
Configurations	

The report layout configurations.

User Login	<p>Select +, and from the dropdown, select a table to add:</p> <ul style="list-style-type: none"> • <i>Summary</i> • <i>Top Success</i> • <i>Top Failure</i> • <i>Top Failure By Reason</i> <p>For additional tables, select + and from the dropdown, select a table.</p>
Maintenance Mode	<p>Select +, and from the dropdown, select a table to add:</p> <ul style="list-style-type: none"> • <i>Summary</i> • <i>Top Activations By User</i> <p>For additional tables, select + and from the dropdown, select a table.</p>
Glassbreaking Mode	<p>Select +, and from the dropdown, select a table to add:</p> <ul style="list-style-type: none"> • <i>Summary</i> • <i>Top Activations By User</i> <p>For additional tables, select + and from the dropdown, select a table.</p>
HA Mode	<p>Select +, and from the dropdown, select a table to add:</p> <ul style="list-style-type: none"> • <i>Summary</i> <p>For additional tables, select + and from the dropdown, select a table.</p>
Secret Launch Success	<p>Select +, and from the dropdown, select a table to add:</p> <ul style="list-style-type: none"> • <i>Summary</i> • <i>Top Success By Secret Name</i> • <i>Top Success By Secret Name and User</i> <p>For additional tables, select + and from the dropdown, select a table.</p>
Password Change	<p>Select +, and from the dropdown, select a table to add:</p> <ul style="list-style-type: none"> • <i>Summary</i> • <i>Top Success By Secret</i> • <i>Top Success By Secret and User</i> • <i>Top Failure By Secret</i> • <i>Top Failure By Secret and Reason</i> • <i>Top Failure By Secret, User and Reason</i> <p>For additional tables, select + and from the dropdown, select a table.</p>
Password Verification	<p>Select +, and from the dropdown, select a table to add:</p> <ul style="list-style-type: none"> • <i>Summary</i> • <i>Top Success By Secret</i> • <i>Top Success By Secret and User</i> • <i>Top Failure By Secret</i> • <i>Top Failure By Secret and Reason</i> • <i>Top Failure By Secret, User and Reason</i> <p>For additional tables, select + and from the dropdown, select a table.</p>
Clear Text View	<p>Select +, and from the dropdown, select a table to add:</p> <ul style="list-style-type: none"> • <i>Summary</i>

- *Top View By Secret*
- *Top View By Secret and User*

For additional tables, select + and from the dropdown, select a table.

Page Break Before Add a page break before one of the following heading levels:

- *Heading 1* (default)
- *Heading 2*
- *Heading 3*

Schedule
Schedule for generating reports.

Automated Generate Enable/disable scheduled report generation.
Note: The option is disabled by default.

Schedule Select a frequency for automatic scheduled report generation:

- *Daily* (default)
- *Weekly*

Day Select a day of the week.
Note: The option is only available when *Schedule* is *Weekly*.

Time Enter the time or select the clock icon and then select the time from the dropdown.

Email
Report related email alerts.

Report to Email Enable/disable sending reports to the specified email.



Before enabling the option, you must configure an email messaging server in *System > Settings* and set up *Email Alert Settings*.
See [Email alert settings on page 302](#)

Note: The option is disabled by default.

Title The email subject starts with the title entered here.

Recipients The recipient email addresses.
Select + to include additional email addresses.

5. Click *Submit*.

CLI configuration to customize report attributes - example

```

config report layout
edit default
config body-item #Configure report body items.
show #By default, a report displays all the available charts.
delete 301 #Deletes Bandwidth and Application related charts.
end

end
execute report-config reset
y #Enter "y" to update the report layout based on the new configuration.
    
```

Secret audit

Secret Audit displays a list secret audit reports.

Secret audit reports make it easier for the management to understand the permission distribution of each secret in the system so that when users change, they can accurately and quickly grasp the addition and deletion of permissions. At the same time, it also allows auditors to globally observe the distribution of permissions of each user and the apparent ownership of each key.

A secret audit report contains the following information about each secret:

- target server
- user account accessing the secret
- folder where the secret resides
- secret name
- user/user group with access to the secret
- secret access permission level for the user accessing the secret

For each report entry; the report name and the date when the report was generated is displayed.



The report name follows the following naming convention:

`SecretAccessAuditReport-YYYY-MM-DD-HHMMSS.csv`

Generate Report		Search
Name	Time	
<input type="checkbox"/> SecretAccessAuditReport-2023-09-27-130847.csv	2023/09/27	
<input type="checkbox"/> SecretAccessAuditReport-2023-09-26-150416.csv	2023/09/26	

The *Secret Audit* tab includes the following options:

Generate Report	Select <i>Generate Report</i> to generate a new secret audit report.
Search	Enter a search term in the search field, then hit Enter to search the reports list. To narrow down your search, see Column filter .
Refresh	To refresh the contents, click the refresh icon.

The following options are available for each of the generated report:

View	Select to view the selected report. When viewed from within FortiPAM, a secret audit report looks like the following:
-------------	--

Target	Account	Folder	Secret Name	User(group)	Permission
		import	www	admin	Owner
		import	www	admin	Owner
	11	sss	test_new	admin	Owner
	11	sss	test_new	winson	List
	11	sss	test_new - copy	admin	Owner
	11	sss	test_new - copy	winson	List
	winson_test	admin	101	admin	Owner
	winson_test	admin	101	winson	View
	winson_test	admin	101 - coafasf	admin	Owner
	winson_test	admin	101 - copy	admin	Owner
	winson_test	admin	101 - copy	winson	View
	winson_test	admin	MR1420-1	admin	Owner
	winson_test	admin	MR1481	admin	Owner
	winson_test	admin	MR1529-Unix-password	admin	Owner
	winson_test	admin	long-template	admin	Owner
	winson_test	admin	putty-cust	admin	Owner
	winson_test	admin	putty-cust	everyone(group)	View

Download

Select to export the selected report to your computer as a csv file.

Delete

Select to delete the selected reports.

CLI configuration to generate secret audit report - example

1. In the CLI console, enter the following command:

```
execute audit secret-access
```

Log settings

Log settings determine what information is recorded in logs, where the logs are stored, and how often storage occurs.

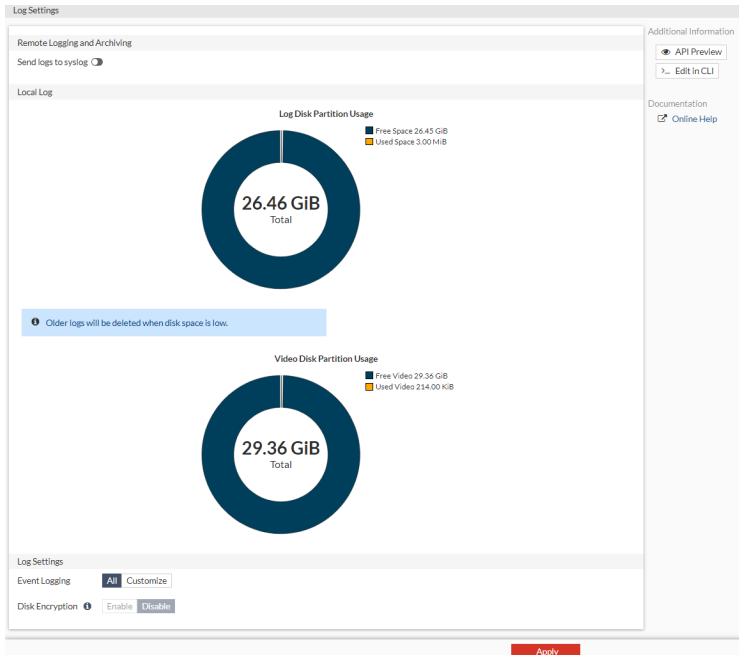

Remote Logging and Archiving

Send logs to syslog

Enable/disable sending logs to syslog.
 When enabled, enter the IP address/FQDN for the syslog.
 See [Configuring parameters to send logs to syslog server on page 297](#).
Note: The option is disabled by default.

Local Log

Log Disk Partition Usage

The disk usage (free and used space).

Video Disk Partition Usage

The video disk partition usage (free and used video disk partition).

Log Settings

Event Logging

By default, the system logs all the events: system activity, user activity, and HA. You can customize event logging by selecting *Customize* and then unselecting options under *Customize*.
Note: No event logs are recorded and displayed on the *Log & Report > Events* page for unselected events.

Disk Encryption

Enable/disable disk encryption on log and video disks. See [Configuring log and video disk encryption on page 298](#).



The setting can only be changed using `execute disk encryption {enable | disable}`.



You must be in maintenance mode to change the setting.



Older logs are deleted when disk space is low.

Disabling disk storage

Although it is not suggested that you disable the disk storage, FortiPAM allows you to disable the disk storage via the CLI.

To disable disk storage:



If you intend to disable the disk storage, ensure that the memory storage is enabled to make the log pages work correctly:

```
config log memory setting
  set status enable
end
```

1. In the CLI console, enter the following commands:

```
config log disk setting
  set status disable
end
```

Configuring parameters to send logs to syslog server

To configure parameters to send logs to syslog server:

1. Go to *Log & Report > Log Settings*.
2. In *Additional Information*, select *Edit in CLI*.
The CLI console opens.
3. Use the following parameters:

<code>status {enable disable}</code>	Enable/disable remote syslog logging (default = disable).
--	---

The following parameters are only available when the `status` is set as `enable`.

<code>server <string></code>	Address of the remote syslog server.
------------------------------------	--------------------------------------

<code>mode {legacy-reliable reliable udp}</code>	The remote syslog logging mode: <ul style="list-style-type: none"> • <code>legacy-reliable</code>: Legacy reliable syslogging by RFC3195 (Reliable Delivery for Syslog). • <code>reliable</code>: Reliable syslogging by RFC6587 (Transmission of Syslog Messages over TCP). • <code>udp</code>: syslogging over UDP (default).
--	--

<code>port <integer></code>	The server listening port number (default = 514, 0 - 65535).
-----------------------------------	--

```
facility {kernel | user | mail
| daemon | auth | syslog | lpr |
news | uucp | cron | authpriv | ftp
| ntp | audit | alert | clock | local0
| local1 | local2 | local3 | local4 |
local5 | local6 | local7}
```

The remote syslog facility (default = `local7`):

- `kernel`: Kernel messages.
- `user`: Random user-level messages.
- `mail`: Mail system.
- `daemon`: System daemons.
- `auth`: Security/authorization messages.
- `syslog`: Messages generated internally by syslog.
- `lpr`: Line printer subsystem.
- `news`: Network news subsystem.
- `uucp`: Network news subsystem.
- `cron`: Clock daemon.
- `authpriv`: Security/authorization messages (private).
- `ftp`: FTP daemon.
- `ntp`: NTP daemon.
- `audit`: Log audit.
- `alert`: Log alert.
- `clock`: Clock daemon.
- `local0` ... `local7`: Reserved for local use.

`source-ip` <string>

The source IP address of syslog.

```
format {cef | csv | default
| rfc5424}
```

The log format:

- `cef`: CEF (Common Event Format) format.
- `csv`: CSV (Comma Separated Values) format.
- `default`: Syslog format (default).
- `rfc5424`: Syslog RFC5424 format.

`priority` {default | low}

The log transmission priority:

- `default`: Set Syslog transmission priority to default (default).
- `low`: Set Syslog transmission priority to low.

`max-log-rate` <integer>

The syslog maximum log rate in MBps (default = 0, 0 - 100000 where 0 = unlimited).

```
interface-select-method {auto |
sdwan | specify}
```

Specify how to select outgoing interface to reach the server:

- `auto`: Set outgoing interface automatically (default).
- `sdwan`: Set outgoing interface by SD-WAN or policy routing rules.
- `specify`: Set outgoing interface manually.

4. After adjusting the parameters, click **x** to close the CLI console.

Configuring log and video disk encryption

FortiPAM allows you to encrypt disk to protect logs and videos. Turning on disk encryption on log and video disks is akin to putting a solid lock on a chest of sensitive information. This keeps all the data safe by making it unreadable to anyone

without a unique key or password. If someone tries to steal or get into the storage devices without permission, they cannot open and access the disk content. This is a crucial defence against any potential leaks or breaches.



Disks can only be encrypted using the CLI console.



Enabling/disabling disk encryption erases all the existing logs and videos.



When log and video disk is encrypted, read/write on disk is slower.

CLI commands for disk encryption

```
execute disk encryption {enable | disable}
execute disk encryption log
execute disk encryption status
execute disk encryption video
```

Command	Description
execute disk encryption enable	Enable disk encryption on log and video disk. Note: The option is only available when disk encryption is disabled.
execute disk encryption disable	Disable disk encryption on log and video disk. Note: The option is only available when disk encryption is enabled.
execute disk encryption log	Check the log disk encryption status.
execute disk encryption status	Check the disk encryption status.
execute disk encryption video	check the video disk encryption status.

To encrypt log and video disks:

1. Enable maintenance mode. See [Enable maintenance mode](#).

In the CLI console, enter the following commands:

```
config system maintenance
  set mode enable
end
```

Note: Disk operations are only allowed when the device is in maintenance mode.

2. In the CLI console, enter the following command:

```
execute disk encryption enable
```

Change disk encryption setting will erase all data in log and video disk.

```
And system will reboot!
Do you want to continue (y/n)y

Add into disk encryption list: /dev/vda1 LOGUSEDXEAE02C3F
Add into disk encryption list: /dev/vdb1 PAMVIDEOC5E34481

Performing encrypt on the requested disk(s) and rebooting, please wait...

Encrypting the disk...
- unmounting /data2 : ok
- unmounting /var/log : ok
- unmounting /var/storage/HD2-PAMVIDEOC5E34481 : ok
Formatting /dev/mapper/dm_log ...
Disk encryption is enabled on /dev/vda1 dm_log
Formatting /dev/mapper/dm_video ...
Disk encryption is enabled on /dev/vdb1 dm_video

The system is going down NOW !!

Please stand by while rebooting the system.
[ 528.501700] reboot: Restarting system

System is starting...
we have 2 interfaces
Serial number is FPAVUL2022103101

FPAVUL2022103101 login:

FortiPAM encrypts and formats both the log and video disks. All the content in log and video disk are erased and FortiPAM reboots.
```



FortiPAM only supports one log and one video disk.



Disk encryption cannot be enabled when there are more than one log or more than one video disk.



You must check the system storage using `configure system storage` and set unused storage status to disable.

3. FortiPAM then automatically generates a random disk-encryption-password and enables disk-encryption.

```
config secret setting
  set disk-encryption enable
  set disk-encryption-password ENC
r7Z4a0307If/m+mqn13p/XVypR6bde1bSTgx4nlmj5ml81/7giR7qHeEMcs7Kg+8sxUHMnR+ezp6HFG3S9yiaPEO
5lR4RzAxy5CxbCCr9WuNCwemr8P+lYOMj56Qaq897xykbd3c+0l+xgeRjNeHwmWo8KWEiRoVop9iQ1RUqO1FKy
```

```
zYmuJy0y5U8Rnv4TGqZpNw==  
end
```



`disk-encryption-password` and `disk-encryption` cannot be set manually.

4. In an HA setup, disk encryption configuration is not synced. All the HA members should have disk encryption configured before joining the cluster. Each HA member uses a different encryption password.
-



You must back up the system configuration of each member of an HA cluster.

To disable disk encryption:

1. Enable maintenance mode. See [Enabling maintenance mode](#).
2. In the CLI console of a FortiPAM device where disk encryption is enabled, enter the following command to disable disk encryption:

```
execute disk encryption disable  
Change disk encryption setting will erase all data in log and video disk.  
And system will reboot!  
Do you want to continue? (y/n)y
```

```
Add into disk decryption list: /dev/vda1 dm_log LOGUSEDXEAE02C3F  
Add into disk decryption list: /dev/vdb1 dm_video PAMVIDEOC5E34481
```

```
Performing decrypt on the requested disk(s) and rebooting, please wait...
```

```
Decrypting the disk...  
- unmounting /data2 : ok  
- unmounting /var/log : ok  
Add into format list: /dev/vda1 LOGUSEDXEAE02C3F  
Add into format list: /dev/vdb1 PAMVIDEOC5E34481
```

```
Formatting the disk...  
Formatting /dev/vda1 label LOGUSEDXEAE02C3F ... done  
Formatting /dev/vdb1 label PAMVIDEOC5E34481 ... done
```

```
The system is going down NOW !!
```

```
Please stand by while rebooting the system.  
[ 117.836312] reboot: Restarting system
```

```
System is starting...  
we have 2 interfaces  
Serial number is FPAVUL2022103101
```

```
FPAVUL2022103101 login:
```

FortiPAM decrypts and formats log and video disks. All the content in log and video disk are erased and FortiPAM reboots. FortiPAM then automatically removes `disk-encryption-password` and sets `disk-encryption` to disable.

For troubleshooting, see [Troubleshooting log and video disk encryption issues on page 389](#).

Email alert settings

Enabling *Email Alert Settings* allows FortiPAM to send alert emails to administrators.

To configure a mail service:

1. Go to *System > Settings*.
2. You can set up the email service from the *Email Service* pane. See [Settings on page 324](#).
By default, the Fortinet mail server is used. You can set up a custom email server by enabling *Use custom settings* in the *Email Service* pane and configuring the related settings.

To enable Email alert setting:

1. Go to *Log & Report > Email Alert Settings*, and select *Enable email notification*.
The following two tabs are available:
 - *Critical System Notification*: Includes setting up glass breaking and license expiring notifications.
 - *General*

2. In the *Critical System Notification* tab, enter the following information:

From	The email address of the sender.
To	The email address of the receiver.



Select + to add additional email addresses.

3. In the *General* tab, enter the following information:

From	The email address of the sender. fortipam@example.com
To	The email address of the receiver. admin1@example.com admin2@example.com
 Select + to add additional email addresses.	
Alert parameter	Select from the following two options: <ul style="list-style-type: none"> • <i>Events</i>: Alerts are sent when an event occurs, e.g., system or user events. See Events on page 281. • <i>Severity</i>: From the dropdown, select the minimum level of severity at which the alerts are sent.
Interval	The time interval at which the alerts are sent, in minutes (default = 5, 1-99999). Note: The option is only available when the <i>Alert parameter</i> is set as <i>Events</i> .
Security	
Note: The pane is only available when the <i>Alert parameter</i> is set as <i>Events</i> .	
Virus detected	Enable/disable sending alerts when virus detected.
Administrative	
Note: The pane is only available when the <i>Alert parameter</i> is set as <i>Events</i> .	
Configuration change	Enable/disable sending alerts when a configuration is changed. Note: The option is disabled by default.
HA status change	Enable/disable sending alerts when the HA status changes. Note: The option is disabled by default.

4. Click *Apply*.

Email alert when the glass breaking mode is activated - example

To set up email alerts when the glass breaking mode is activated:

1. Ensure that *Email Service* is set up in *System > Settings*. See [Settings on page 324](#).
2. Go to *Log & Report > Email Alert Settings*, and select *Enable email notification*.
3. In the *Critical System Notification* tab:
 - a. In *From*, enter the email address of the sender.
 - b. In *To*, enter the email address of the receiver.
4. Click *Apply*.



Setting up an email alert for glass breaking excludes other important notifications, e.g., administrative change (configuration and HA status) and security (virus detection).

Debug settings

Customer Support may request a copy of your debug logs for troubleshooting.

Go to *Log & Report > Debug Settings* and click *Download* in the *Debug Settings* pane to download the debug logs for troubleshooting.

Trace logs

FortiPAM trace GUI tool is available in the *Trace Logs* pane in *Log & Report > Debug Settings*.

To set up and download trace logs:

1. Go to *Log & Report > Debug Settings*.
The *Debug Settings* window opens.

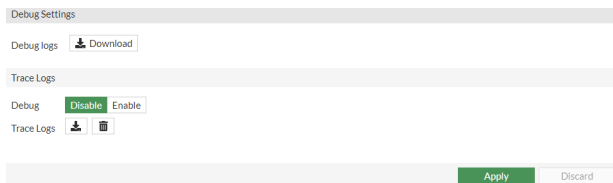

2. In the *Trace Logs* pane, enter the following information:

Debug

Enable/disable trace logs.

Note: The option is disabled by default.

Category

Select + and then select categories to trace from the *Select Entries* window. Click *Close* once you have selected all the required trace categories.



Use the search bar to look up a trace category.

Note: The option is only available when *Debug* is enabled.

Debug Level

From the dropdown, select a debug level for the trace:

- *Verbose*
- *Info* (default)
- *Warning*
- *Error*

Note: The option is only available when *Debug* is enabled.

Filter

From the dropdown, select a filter:

- *None* (default)
- *Internal*
- *TCP Forwarding*
- *Both*

See [FortiPAM HTTP filter on page 386](#).

Note: The option is only available when *Debug* is enabled.

Overwrite

Enable/disable overwriting when the file reaches maximum size.

Note:

- The option is disabled by default.
- The option is only available when *Debug* is enabled.

Drop Unknown Session

Enable to drop unknown sessions.

See [FortiPAM HTTP filter on page 386](#).

Note:

- The option is disabled by default.
- The option is only available when *Debug* is enabled.



Maximum File Size

The maximum size for each trace log file, in MB (default = 1, 1 - 10).

Note: The option is only available when *Debug* is enabled.

Trace Logs

Select from the following two options:

- : Download all the trace logs.
- : Clear all the log traces.

3. Click *Apply*.

When FortiPAM is recording trace logs, a list of the logs appears in *Trace Logs*. You can download or view a trace log by clicking the eye or the download icon next to the trace log.



Viewing does not stop the trace recording, but downloading turns off the trace recording.

Trace Logs			
File Name	Size	View	Download
wad_pwd-changer-0.log	1.29 KB		
wad_worker-0.log	384.81 KB		
wad_config-notify-0.log	95 Bytes		

When you click the eye icon next to a trace log, you can view it.

```

[1]_wad_dns_send_query :767 0:0: sending DNS request for remote peer google.ca id=0 IPv4
[1]_wad_dns_send_query :767 0:0: sending DNS request for remote peer linux-server.ca id=1
IPv4
[1]_wad_dns_send_query :767 0:0: sending DNS request for remote peer google.ca id=2 IPv4
[1]_wad_dns_parse_name_resp :205 0: DNS response received for remote host google.ca req-id=0
ipV4=1
[1]_wad_dns_parse_name_resp :205 0: DNS response received for remote host google.ca req-id=2
ipV4=1
[1]_wad_dns_parse_name_resp :205 0: DNS response received for remote host linux-server.ca req-
id=1 ipV4=1
[1]_wad_dns_send_query :767 0:0: sending DNS request for remote peer google.ca id=0 IPv4
[1]_wad_dns_send_query :767 0:0: sending DNS request for remote peer linux-server.ca id=1
IPv4
[1]_wad_dns_send_query :767 0:0: sending DNS request for remote peer google.ca id=2 IPv4
[1]_wad_dns_parse_name_resp :205 0: DNS response received for remote host google.ca req-id=2
ipV4=1
[1]_wad_dns_parse_name_resp :205 0: DNS response received for remote host google.ca req-id=0
ipV4=1
[1]_wad_dns_parse_name_resp :205 0: DNS response received for remote host linux-server.ca req-
id=1 ipV4=1
[1]_wad_dns_send_query :767 0:0: sending DNS request for remote peer google.ca id=0 IPv4
[1]_wad_dns_send_query :767 0:0: sending DNS request for remote peer linux-server.ca id=1
IPv4
[1]_wad_dns_send_query :767 0:0: sending DNS request for remote peer google.ca id=2 IPv4
[1]_wad_dns_parse_name_resp :205 0: DNS response received for remote host google.ca req-id=0
ipV4=1
[1]_wad_dns_parse_name_resp :205 0: DNS response received for remote host google.ca req-id=2
ipV4=1
[1]_wad_dns_parse_name_resp :205 0: DNS response received for remote host linux-server.ca req-
id=1 ipV4=1
[1]_wad_dns_send_query :767 0:0: sending DNS request for remote peer google.ca id=0 IPv4
[1]_wad_dns_send_query :767 0:0: sending DNS request for remote peer google.ca id=1 IPv4
[1]_wad_dns_parse_name_resp :205 0: DNS response received for remote host google.ca req-id=0
ipV4=1
[1]_wad_dns_parse_name_resp :205 0: DNS response received for remote host google.ca req-id=1
ipV4=1

```

4. When the diagnostic is finished, disable *Debug* to stop recording.

Automation trigger settings

FortiPAM can be configured to perform actions when an event log is triggered. This is in the system automation table.



Automation trigger settings can only be configured via the CLI.

Automation trigger settings via the CLI - Example

To configure automation trigger settings:

1. In the CLI console, enter the following commands:

```

config system automation-trigger
  edit "fold_chg"
    set event-type event-log
    set logid 44547 44548 #from the log id "0100044547". Remove the first 5 digits
(category/subcategory prefix)
    set category 1 #first 2 digits of the log ID "01"
    set logic and
  config fields
    edit 1
      set match regex
      set name "msg"
      set value "E*t"
    next
    edit 2
      set name "user"

```

```
    set value "ul"  
  next  
end  
next  
end
```



If the field is set to match regex, it uses the regular expression to match the field with the value `_name_`. Otherwise, it uses the default match, using `_*` character as a wildcard.



If the logic is set to `_and_`, all fields must match to trigger the action. Otherwise, if it is set to `_or_`, any field matching triggers the action.

Network

Go to *Network* to configure network related settings for FortiPAM.

The menu provides features for configuring and viewing basic network settings, such as the unit interfaces, static routes, Domain Name System (DNS) options, fabric connectors, and packet capture.

The *Network* tab contains the following tabs:

- [Interfaces on page 308](#)
- [Static routes on page 312](#)
- [DNS settings on page 315](#)
- [Fabric Connectors on page 317](#)
- [Packet capture on page 322](#)

Interfaces

In *Network > Interfaces*, you can configure the interfaces that handle incoming and outgoing traffic.

For each interface/zone; name, type, members, IP/Netmask, administrative access, and references are displayed.

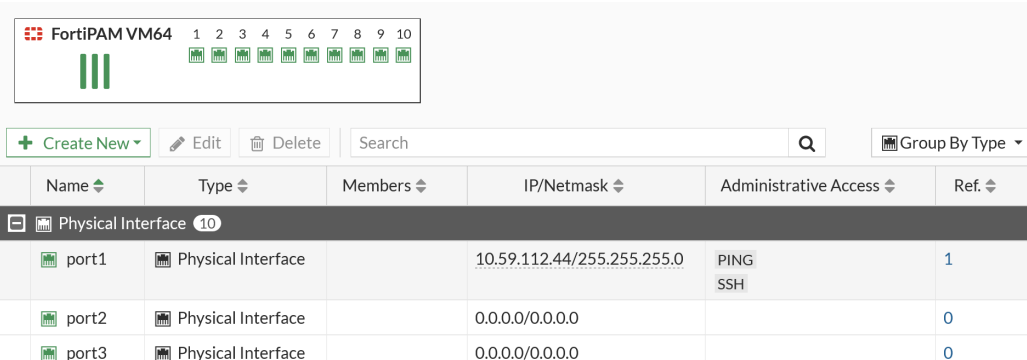

Name	Type	Members	IP/Netmask	Administrative Access	Ref.
port1	Physical Interface		10.59.112.44/255.255.255.0	PING SSH	1
port2	Physical Interface		0.0.0.0/0.0.0.0		0
port3	Physical Interface		0.0.0.0/0.0.0.0		0



Hover over the leftmost edge of the column heading to display the *Configure Table* icon, which you can use to select the columns to display or to reset all the columns to their default settings. You can also drag column headings to change their order.

The following options are available in the *Interface* tab:

+Create New

Select to create an interface or a zone. See [Creating an interface on page 309](#) and [Creating a zone on page 312](#).

Edit

Select to edit the selected interface or zone.

Delete

Select to delete the selected interfaces or zones.

Search	Use the search bar to look for an interface or a zone.
Group By Type	From the dropdown, group the list of interfaces or zones by type, role, status, or zone. You may also choose to set no grouping.
Refresh	To refresh the contents, click the refresh icon on the bottom-right.

Creating an interface



To create an interface:

1. Go to *Network > Interfaces*.
2. From **+Create New**, select *Interface*.

The *New Interface* window opens.

3. Enter the following information:

Name	Name of the interface.
Alias	Enter an alternate name for a physical interface on the FortiPAM device. This field appears when you edit an existing interface. The alias does not appear in logs. The maximum length of the alias is 25 characters.
Type	From the dropdown, select a configuration type: <ul style="list-style-type: none"> • <i>802.3ad Aggregate</i> • <i>Redundant Interface</i> • <i>VLAN</i> (default)
VLAN protocol	Select either <i>802.1Q</i> or <i>802.1AD</i> . Note: The field is available when <i>Type</i> is set to <i>VLAN</i> .
Interface	Select the name of the physical interface that you want to add a VLAN interface to. Once created, the VLAN interface is listed below its physical interface in the Interface list.

	 <p>You cannot change the physical interface of a VLAN interface.</p>
	 <p>Use the search bar to look for an interface.</p>
	 <p>Use the pen icon next to an interface to edit the interface.</p>
<p>Note: The field is available when <i>Type</i> is set to <i>VLAN</i>.</p>	
<p>VLAN ID</p>	<p>Enter the VLAN ID. The VLAN ID can be any number between 1 and 4094 and must match the VLAN ID added by the IEEE 802.1Q-compliant router or switch that is connected to the VLAN subinterface.</p> <p>The VLAN ID can be edited after the interface is added.</p> <p>Note: The field is available when <i>Type</i> is set to <i>VLAN</i>.</p>
<p>Interface members</p>	<p>Select members for some interface types.</p> <p>Note: The field is available when <i>Type</i> is set to <i>802.3ad Aggregate</i> or <i>Redundant Interface</i>.</p>
<p>Role</p>	<p>Set the role setting for the interface. Different settings will be shown or hidden when editing an interface depending on the role:</p> <ul style="list-style-type: none"> • <i>LAN</i>: Used to connected to a local network of endpoints. It is default role for new interfaces. • <i>WAN</i>: Used to connected to the internet. When <i>WAN</i> is selected, the <i>Estimated bandwidth</i> setting is available, and <i>Create address object matching subnet</i> is not available. • <i>DMZ</i>: Used to connected to the DMZ. • <i>Undefined</i>: The interface has no specific role. When selected, <i>Create address object matching subnet</i> is not available.
<p>Estimated bandwidth</p>	<p>The estimated WAN bandwidth, in kbps (upstream and downstream).</p> <p>The values can be entered manually, or saved from a speed test executed on the interface. These values are used to estimate WAN usage.</p> <p>Note: The option is only available when the <i>Role</i> is set as <i>WAN</i>.</p>
<p>Address</p>	
<p>Addressing mode</p>	<p>Select the addressing mode for the interface.</p> <ul style="list-style-type: none"> • <i>Manual</i>: Add an IP address and netmask for the interface. • <i>DHCP</i>: Get the interface IP address and other network settings from a DHCP server.
<p>IP/Netmask</p>	<p>If <i>Addressing mode</i> is set to <i>Manual</i>, enter an IPv4 address and subnet mask for the interface.</p>



FortiPAM interfaces cannot have IP addresses on the same subnet.

Note: The option is only available when the *Addressing mode* is *Manual*.

Retrieve default gateway from server

Enable to retrieve the default gateway from the server.
The default gateway is added to the static routing table.

Note: The option is enabled by default.

Note: The option is only available when the *Addressing mode* is *DHCP*.

Distance

Enter the administrative distance for the default gateway retrieved from the DHCP server (default = 5, 1 - 255).

Distance specifies the relative priority of a route when there are multiple routes to the same destination. A lower administrative distance indicates a more preferred route.

Note: The option is only available when *Retrieve default gateway from server* is enabled.

Override internal DNS

Enable to use the DNS addresses retrieved from the DHCP server instead of the DNS server IP addresses on the DNS page.

Note: The option is enabled by default.

Note: The option is only available when the *Addressing mode* is *DHCP*.

Create address object matching subnet

Enable to automatically create an address object that matches the interface subnet.

Note: The option is enabled by default.

Note: The option is available when *Role* is set to *LAN* or *DMZ*.

Secondary IP address

Add additional IPv4 addresses to this interface.

Note: The option is disabled by default.

Note: The option is only available when the *Addressing mode* is *Manual*.

Administrative Access

IPv4

Select the types of administrative access permitted for IPv4 connections to this interface:

- *PING*
- *SSH*
- *SNMP*
- *FTM*

Miscellaneous

Comments

Optionally, enter comments about the source interface.

Status

Enable/disable the source interface.

Explicit web proxy

Enable/disable explicit web proxy to proxy HTTP and HTTPS traffic.

4. Click *OK*.



Creating a zone

To create a zone:

1. Go to Network > Interface.
2. From **+Create New**, select **Zone**.

The **New Zone** window opens.

3. Enter the following information:

Name	Name of the zone. You can change the name of the zone after creating it.
Interface members	Select the ports to be included in the zone or create new ports.
	 Use the search bar to look for an interface.
	 Use the pen icon next to an interface to edit the interface.
Comments	Optionally, enter a description about the zone.

4. Click **OK**.

Static routes

Go to **Network > Static Routing** to see a list of static routes that control the flow of traffic through the FortiPAM device.

For each static route; destination, gateway IP address, interface, status, and comments are displayed.

Destination	Gateway IP	Interface	Status	Comments
0.0.0.0	10.59.112.1	port1	Enabled	



Hover over the leftmost edge of the column heading to display the *Configure Table* icon, which you can use to select the columns to display or to reset all the columns to their default settings. You can also drag column headings to change their order.

The following options are available in the **Static Routes** tab:

+Create New	From the dropdown, select to create an IPv4 static route. See Creating an IPv4 static route on page 313 .
--------------------	---

Edit	Select to edit the selected static route.
Clone	Select to clone the selected static route.
Delete	Select to delete the selected static route.
Search	Use the search bar to look for a static route.

Creating an IPv4 static route

To create an IPv4 static route:

1. Go to *Network > Static Routes*.
2. Select *Create New* to create a new IPv4 static route.

The *New Static Route* window opens.

NewStatic Route

Destination Subnet
0.0.0.0/0.0.0.0

Gateway Address
0.0.0.0

Interface
+
This field is required.

Administrative Distance 10



Comments
Write a comment... 0/255

Status Enabled Disabled

Advanced Options

OK Cancel

3. Enter the following information:

Destination	<p>The destination IP addresses and network masks of packets that the FortiPAM unit intercepts.</p> <p>Enter the IPv4 address and netmask of the new static route.</p>
Gateway Address	<p>The IP addresses of the next-hop routers to which intercepted packets are forwarded.</p> <p>Enter the gateway IP address for those packets that you intend to intercept.</p> <p>Note: <i>Gateway Address</i> is unavailable when the <i>Interface</i> is <i>Blackhole</i>.</p>
Interface	<p>The interface the static route is configured to.</p> <p>Select + and in <i>Select Entries</i>, select the interface or create a new interface.</p> <p>A blackhole route is a route that drops all traffic sent to it. Blackhole routes are used to dispose of packets instead of responding to suspicious inquiries. This provides added security since the originator will not discover any information from the target network. Blackhole routes can also limit traffic on a subnet. If some subnet addresses are not in use, traffic to those addresses, which may be valid or malicious, can be directed to a blackhole for added security and to reduce traffic on the subnet.</p> <hr/> <div style="display: flex; align-items: center;">  <p>Use the search bar to look for an interface.</p> </div> <hr/> <div style="display: flex; align-items: center;">  <p>Use the pen icon next to an interface to edit the interface.</p> </div> <hr/>
Administrative Distance	<p>The number of hops the static route has to the configured gateway.</p> <p>The administrative distance is used to determine the cost of the route. Smaller distances are considered "better" route that should be used when multiple paths exist to the same destination (default = 10, 1 - 255).</p> <p>The route with same distance are considered as equal-cost multi-path (ECMP).</p>
Comments	Optionally, enter a description about the static route.
Status	Enable/disable the static route.
Advanced Options	
Priority	<p>A number for the priority of the static route. Routes with a larger number will have a lower priority. Routes with the same priority are considered as ECMP (default = 1 when creating an IPv4 static route, 1 - 65535).</p> <hr/> <div style="display: flex; align-items: center;">  <p>Priority can only be customized for statically configured routes. The priority of routes dynamically learned from the routing protocols is always 1.</p> </div> <hr/>

API Preview

The *API Preview* allows you to view all REST API requests being used by the page. You can make changes on the page that are reflected in the API request preview.



The feature is not available if the user is logged in as an administrator that has read-only GUI permissions.

4. Click *OK*.

To use API preview:

1. Click *API Preview*.
The *API Preview* pane opens, and the values for the fields are visible (data). If a new object is being created, the POST request is shown.
2. Enable *Show modified changes only* (enabled by default) to show the modified changes instead of the full configuration in the preview.
3. Click *Copy to Clipboard* to copy the JSON code shown on the preview screen to the clipboard.
4. Click *Close* to leave the preview.

DNS settings

Domain name system (DNS) is used by devices to locate websites by mapping a domain name to a website's IP address.

You can specify the IP addresses of the DNS servers to which your FortiPAM unit connects.

To configure DNS settings, go to *Network > DNS Settings*.

To configure DNS settings:

1. Go to *Network > DNS Settings*.

DNS Settings

DNS servers Use FortiGuard Servers Specify

Primary DNS server 96.45.45.45 10ms

Secondary DNS server 96.45.46.46 10ms

Local domain name

DNS Protocols

DNS (UDP/53)

TLS (TCP/853)

HTTPS (TCP/443)



IPv6 DNS Settings

Primary DNS server

Secondary DNS server

Apply

2. In the *DNS Settings* window, enter the following information:

DNS servers	Select <i>Use FortiGuard Servers</i> or <i>Specify</i> . If you select <i>Specify</i> , enter the IP addresses for the primary and secondary DNS servers.
Primary DNS server	Enter the IPv4 or IPv6 address for the primary DNS server. Note: For an IPv4 address, the option is only available to edit when <i>DNS servers</i> is <i>Specify</i> .
Secondary DNS server	Enter the IPv4 or IPv6 address for the secondary DNS server. Note: For an IPv4 address, the option is only available to edit when <i>DNS servers</i> is <i>Specify</i> .
Local domain name	The domain name to append to addresses with no domain portion when performing DNS lookups. <hr/>  Select + to add additional local domain names. <hr/>  You can add up to 8 local domain names. <hr/>
DNS Protocols	
DNS (UDP/53)	Enable or disable the use of clear-text DNS over port 53. Note: The option is disabled by default and only available to edit when <i>DNS servers</i> is <i>Specify</i> .
TLS (TCP/853)	Enable or disable the use of DNS over TLS (DoT). Note: The option is enabled by default and only available to edit when <i>DNS servers</i> is <i>Specify</i> .
HTTPS (TCP/443)	Enable or disable the use of DNS over HTTPS (DoH). Note: The option is disabled by default and only available to edit when <i>DNS servers</i> is <i>Specify</i> .
SSL certificate	From the dropdown, select an SSL certificate or click <i>Create</i> to import a certificate (default = <code>Fortinet_Factory</code>). SSL certificate is used by the DNS proxy as a DNS server so that the DNS proxy can provide service over TLS as well as normal UDP/TCP. <hr/>  Use the search bar to look for an SSL certificate. <hr/>
Server hostname	The host name of the DNS server (default = <code>globalsdns.fortinet.net</code>).



You can add up to 4 server hostnames.

3. Click *Apply*.

To use API preview:

1. Click *API Preview*.

The *API Preview* pane opens, and the values for the fields are visible (data). If a new object is being created, the POST request is shown.

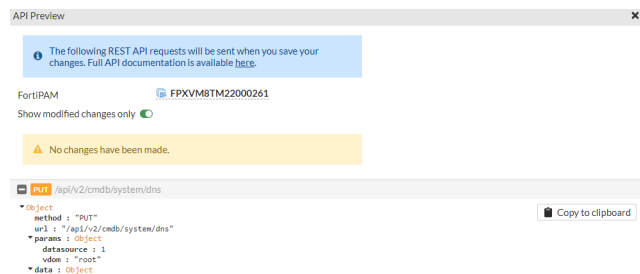

2. Enable *Show modified changes only* (enabled by default) to show the modified changes instead of the full configuration in the preview.
3. Click *Copy to Clipboard* to copy the JSON code shown on the preview screen to the clipboard.
4. Click *Close* to leave the preview.

Security fabric

The Security Fabric allows your network to automatically see and dynamically isolate affected devices, partition network segments, update rules, push out new policies, and remove malware.

The Security Fabric is designed to cover the entire attack surface and provide you with complete visibility into your network. It allows you to collect, share, and correlate threat intelligence between security and network devices, centrally manage and orchestrate policies, automatically synchronize resources to enforce policies, and coordinate a response to threats detected anywhere across the extended network. The unified management interface provides you with cooperative security alerts, recommendations, audit reports, and full policy control across the Security Fabric that will give you confidence that your network is secure.

See [Fabric Connectors](#) on page 317.

Fabric Connectors

Fabric connectors provide integration with Fortinet products to automate the process of managing dynamic security updates without manual intervention.

In HA and DR setup, the EMS configuration, such as server name and IP, can be synced to secondary and DR nodes. However, secondary and DR nodes need to be authorized by EMS individually. It is recommended that after configuring

HA, admin test failover, log in to the new primary, and follow the same procedure to authorize secondary and DR nodes on the EMS server.

To create a FortiClient EMS fabric connector:

1. Go to *Network > Fabric Connectors*.
2. In the *Core Network Security* pane, select *FortiClient EMS* and then select *Edit*. The *New Fabric Connector* pane opens.

3. Enter the following information:

Type	Select from the following two options: <ul style="list-style-type: none"> • <i>FortiClient EMS</i> • <i>FortiClient EMS Cloud</i>
	 <p>The <i>FortiClient EMS Cloud</i> option requires FortiClient EMS Cloud entitlementment.</p>
Name	The name of the FortiClient EMS connector.
IP/Domain name	The IP address or the domain name of the FortiClient EMS.
HTTPS port	The HTTPS port number for the FortiClient EMS (default = 443, 1 - 65535).
EMS Threat Feed	Enable to allow FortiPAM to pull FortiClient malware hash from FortiClient EMS. Note: The option is enabled by default.
Synchronize firewall addresses	Enable to automatically create and synchronize firewall addresses for all EMS tags. Note: The option is enabled by default.

4. Click *OK*.
FortiPAM attempts to verify the EMS server certificate.

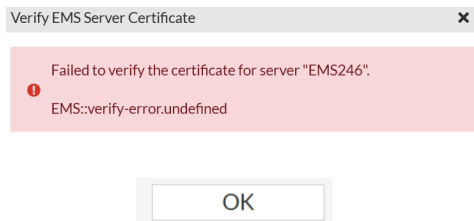

To delete a fabric connector, select *Delete* to delete the selected fabric connector.

5. Relogin to the EMS server.
Fabric Device Authorization Requests prompt appears.

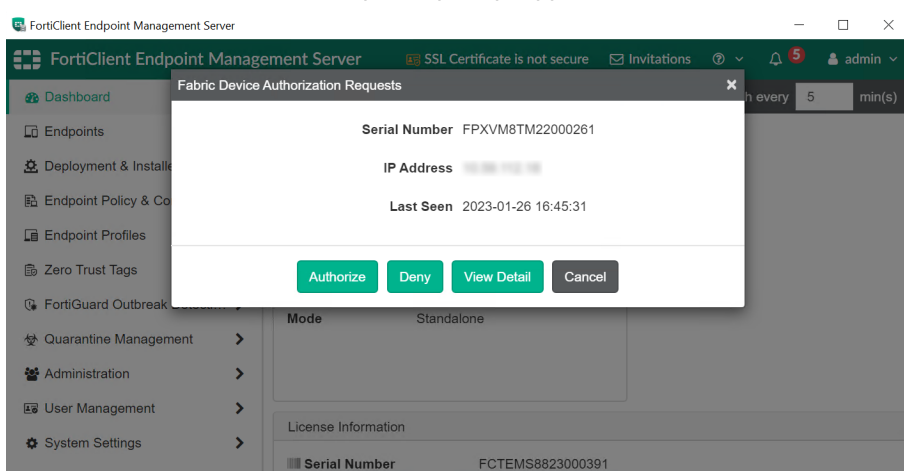

6. In *Fabric Device Authorization Requests*, click *Authorize* to authorize FortiPAM connection.
7. In the *Edit Fabric Connector* pane on FortiPAM (for the newly configured connector), click *Authorize* in *FortiClient EMS Status*.

Verify EMS Server Certificate window appears.

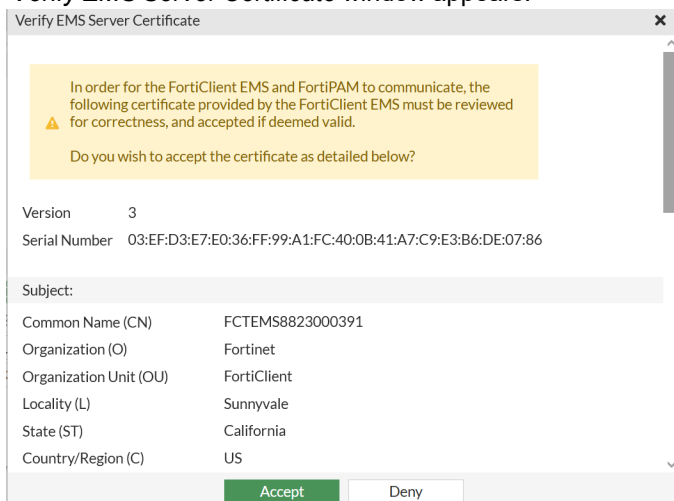

8. In the *Verify EMS Server Certificate* window, select *Accept* to accept the certificate from the EMS-side. FortiPAM is now successfully connected to the EMS server.

FortiAnalyzer logging

FortiAnalyzer is a remote logging server that helps keep an additional copy of logs from FortiPAM.

To configure FortiAnalyzer logging:

1. Go to *Network > Fabric Connectors*.
Core Network Security opens.

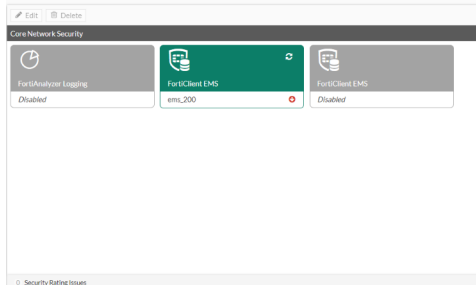

2. Select *FortiAnalyzer Logging* and select *Edit*.
The *Edit Fabric Connector* window opens.

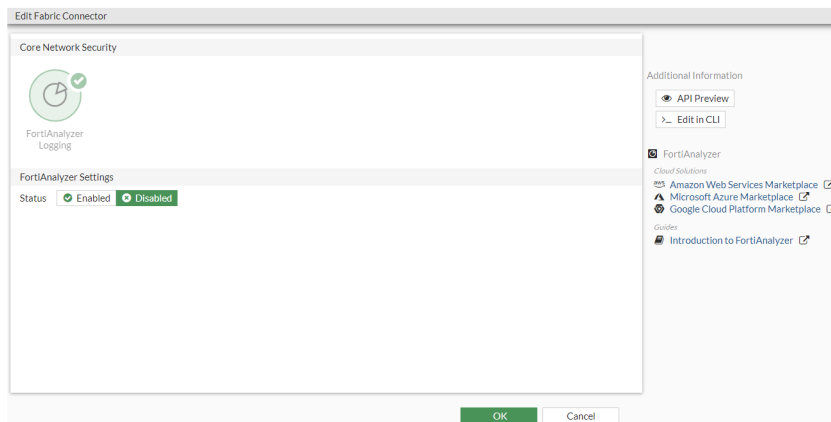

3. In the *FortiAnalyzer Settings* pane, set the *Status* as *Enabled*.
You now see new options in the *Edit Fabric Connector* window.

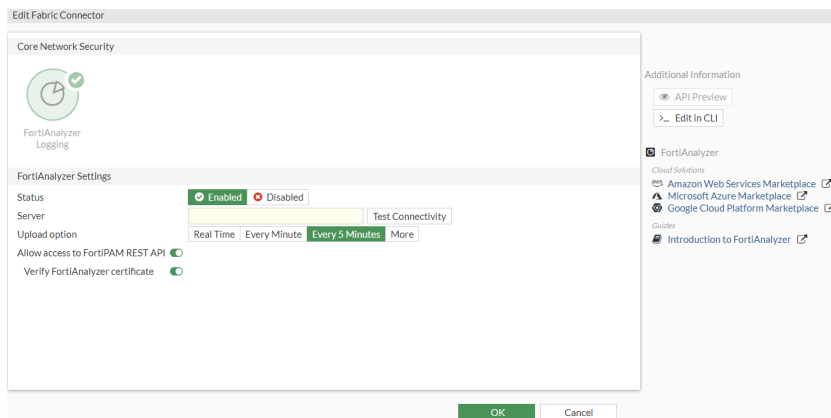

4. Enter the following information:

Server	Enter the server IP address or the FQDN. Select <i>Test Connectivity</i> to test the connection to the server.
Upload option	Select an upload interval: <ul style="list-style-type: none"> • <i>Real Time</i> • <i>Every Minute</i> • <i>Every 5 Minute</i> (default) • <i>More</i>
Upload interval	Select an upload interval: <ul style="list-style-type: none"> • <i>Daily</i> (default) • <i>Weekly</i> • <i>Monthly</i> <p>Note: The option is only available when the <i>Upload option</i> is set to <i>More</i>.</p>
Day	From the dropdown, select a day. Note: The option is only available when the <i>Upload interval</i> is <i>Weekly</i> .
Date	Enter a date for the month. Note: The option is only available when the <i>Upload interval</i> is <i>Monthly</i> .
Time	Enter a time or select the clock icon to select a time.
Allow access to FortiPAM REST API	Enable/disable FortiPAM REST API access (default = enable).
Verify FortiAnalyzer certificate	Enable/disable verifying the FortiAnalyzer certificate (default = enable). Note: The option is only available when <i>Allow access to FortiPAM REST API</i> is enabled.

5. Click *OK*.6. In the window that opens, verify the FortiAnalyzer serial number and click *Accept*.7. Check the *FortiAnalyzer Status*. If the connection is unauthorized, click *Authorize* to log in to FortiAnalyzer and authorize FortiPAM.

After establishing a connection between FortiPAM and FortiAnalyzer, subsequent logs are accessible in the corresponding FortiAnalyzer.



When reviewing logs in *Log & Report*, you can choose *FortiAnalyzer* as the log source. See [Log & report on page 277](#).

To configure FortiAnalyzer logging via the CLI - Example

```
config log fortianalyzer setting
  set status enable
  set server faz.fortipam.ca
end
```

Packet capture

You can create a filter on an interface to capture a specified number of packets to examine.

Go to *Network > Packet Capture* to see existing packet capture filters.

For each packet capture filter the following are displayed:

- Interfaces
- Host filter
- Port filter
- VLAN filter
- Protocol filter
- Packets
- Maximum packet count
- Status

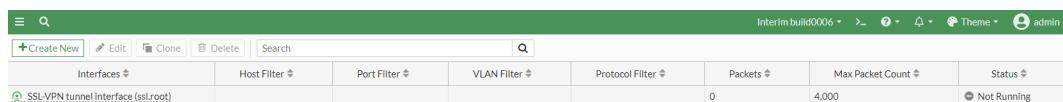

Interfaces	Host Filter	Port Filter	VLAN Filter	Protocol Filter	Packets	Max Packet Count	Status
SSLVPN tunnel interface (ssl.root)					0	4,000	Not Running



Hover over the leftmost edge of the column heading to display the *Configure Table* icon, which you can use to select the columns to display or to reset all the columns to their default settings. You can also drag column headings to change their order.

The following options are available in the *Packet Capture* tab:

+Create New	Select to create a new packet capture filter. See Creating a packet capture filter on page 322 .
Edit	Select to edit the selected packet capture filter.
Clone	Select to clone the selected packet capture filter.
Delete	Select to delete the selected packet capture filter.
Search	Use the search bar to look for a packet capture filter.

Creating a packet capture filter

To create a packet capture filter:

1. Go to *Network > Packet Capture*.
2. Select **+Create New**.

The *New Packet Capture Filter* window opens.

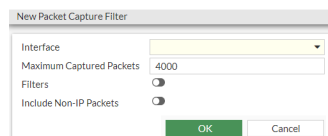

New Packet Capture Filter





Interface:

Maximum Captured Packets:

Filters:

Include Non-IP Packets:

3. Enter the following information:

Interface	<p>Select or create a new interface.</p> <hr/> <div style="display: flex; align-items: center;">  <p>Use the search bar to look for an interface.</p> </div> <hr/> <div style="display: flex; align-items: center;">  <p>Use the pen icon next to an interface to edit the interface.</p> </div>
Maximum Captured Packets	<p>Enter how many packets to collect (default = 4000, 1 - 1000000).</p>
Filters	<p>Enable <i>Filters</i>, you can create filters for host names, ports, VLAN identifiers, and protocols.</p> <hr/> <div style="display: flex; align-items: center;">  <p>Use commas to separate items. Use a hyphen to specify a range.</p> </div> <hr/> <p>Note: The option is disabled by default.</p>
Include Non-IP Packets	<p>Select this option if you want to include packets from non-IP protocols.</p> <p>Note: The option is disabled by default.</p>
API Preview	<p>The <i>API Preview</i> allows you to view all REST API requests being used by the page. You can make changes on the page that are reflected in the API request preview.</p> <hr/> <div style="display: flex; align-items: center;">  <p>This feature is not available if the user is logged in as an administrator that has read-only GUI permissions.</p> </div>

4. Click *OK*.**To use API preview:**

1. Click *API Preview*.
The *API Preview* pane opens, and the values for the fields are visible (data). If a new object is being created, the POST request is shown.
2. Enable *Show modified changes only* (enabled by default) to show the modified changes instead of the full configuration in the preview.
3. Click *Copy to Clipboard* to copy the JSON code shown on the preview screen to the clipboard.
4. Click *Close* to leave the preview.

System

Go to *System* to manage and configure the basic system options for FortiPAM.

You can also manage certificates, edit replacement messages, set up HA cluster and SNMP, and configure ZTNA related settings, automated backup, firmware upgrades, FortiPAM and FortiGuard licenses.

System contains the following tabs:

- [Settings on page 324](#)
- [ZTNA on page 332](#)
- [High availability on page 341](#)
- [Certificates on page 349](#)
- [Replacement messages on page 359](#)
- [SNMP on page 367](#)
- [Backup on page 374](#)
- [Firmware on page 380](#)
- [FortiPAM license on page 381](#)
- [FortiGuard license on page 382](#)

Settings

Go to *System > Settings* to access system configuration that you can update after installing FortiPAM.

To update System Settings:

1. Go to *System > Settings*.
The *General* tab in the *System Settings* window opens.

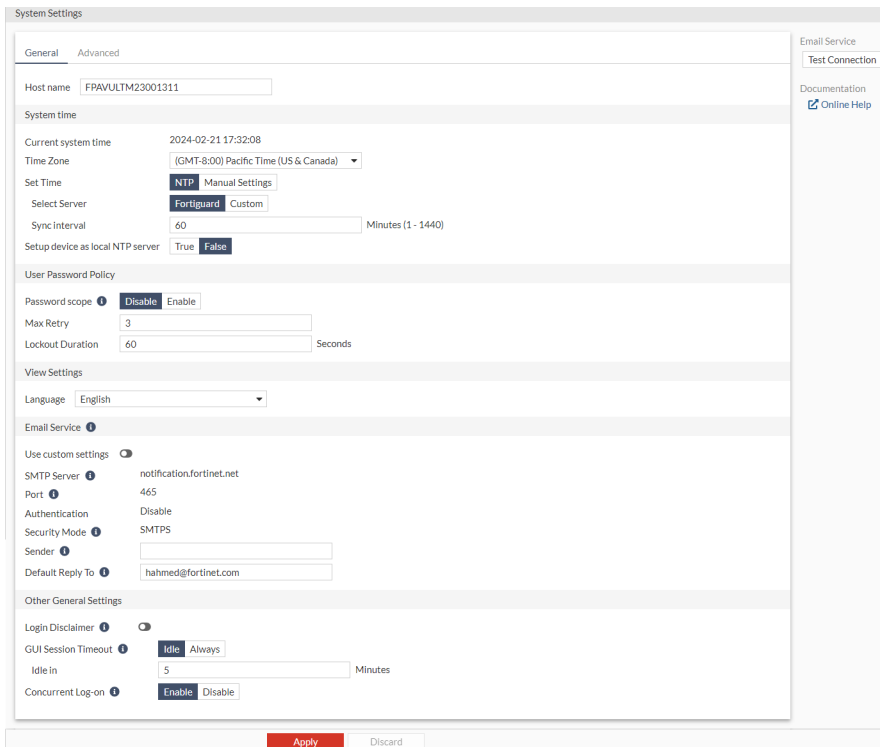

2. To switch to the *Advanced* tab, select *Advanced*.

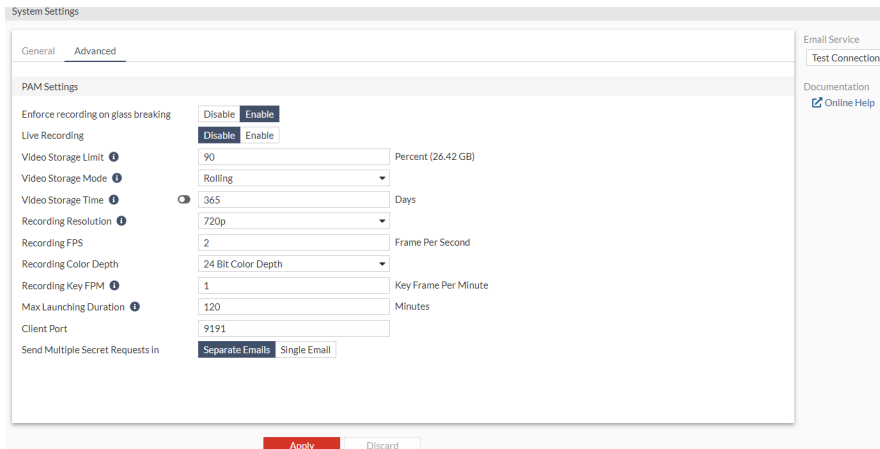

3. In *System Settings*, enter the following information:

General tab

Host name The identifying name assigned to this FortiPAM unit.

System time pane

System time

Current system time The current date and time on the FortiPAM internal clock or NTP servers.

Time Zone From the dropdown, select a timezone.

Set Time	Select from the following options: <ul style="list-style-type: none"> • <i>NTP</i>: The NTP (Network Time Protocol) server (default). • <i>Manual Settings</i>
Select Server	Select a server from the following two options: <ul style="list-style-type: none"> • <i>FortiGuard</i> (default) • <i>Custom</i> <p>Note: The option is only available when <i>Set Time</i> is <i>NTP</i>.</p>
Custom Server IP Address	The custom server IP address.
	<div style="text-align: center;">  <p>Custom NTP server details must be configured via the CLI.</p> </div> <p>Note: The option is only available when <i>Set Time</i> is <i>NTP</i> and the <i>Select Server</i> is <i>Custom</i>.</p>
Sync internal	Enter how often, in minutes, that the device synchronizes its time with the NTP server (default = 60, 1 - 1440). <p>Note: The option is only available when <i>Set Time</i> is <i>NTP</i>.</p>
Date	Enter the date or select the calendar icon, and from the dropdown, select a date. <p>Note: The option is only available when <i>Set Time</i> is <i>Manual Settings</i>.</p>
Time	Enter the time or select the clock icon, and from the dropdown, select a time. <p>Note: The option is only available when <i>Set Time</i> is <i>Manual Settings</i>.</p>
Setup device as local NTP server	Select <i>True</i> to configure the FortiPAM as a local NTP server (default = <i>False</i>).
Listen on Interfaces	Set the interface or interfaces that the FortiPAM will listen for NTP requests on. <p>Note: The option is only available when <i>Setup device on local NTP server</i> is set as <i>True</i>.</p>

User Password Policy pane



User Password Policy	
Password scope	Enable/disable password scope (default = disable). <p>Note: This applies to local user passwords.</p>
Minimum length	The minimum length of the password (default = 8, 1 - 128).
Minimum number of new characters	Enter the minimum number of new characters required in the password (default = 0, maximum = 200).
Character requirements	Enable/disable character requirements (default = disable). <p>When enabled, enter the number of upper case, lower case, numbers, and special (non-alphanumeric) characters required in the password.</p> <p>Note: Special characters are non-alphanumeric.</p>

Allow password reuse	Enable/disable password reuse (default = enable).
Password expiration	Enable and enter the number of days after which the password expires (default = 90, 0 - 999).
Max Retry	Enter the maximum number of allowed failed login attempts (default = 3, 1 - 10).
Lockout Duration	Specify the length of the lockout period, in seconds (default = 60, 1 - 2147483647). Note: After the lockout duration expires, the <i>Max Retry</i> number applies again.

View *Settings* pane

View Settings	
Language	From the dropdown, select a language.

Email *Service* pane

Email Service	
See Testing the email service connection example on page 330 .	
Use custom settings	Enable to edit options in the <i>Email Service</i> pane.
SMTP Server	The SMTP server IP address or the hostname, e.g., <code>smtp.example.com</code> and <code>notification.fortinet.net</code> .
Port	The recipient port number. <hr/>  The default port value depends on the chosen <i>Security Mode</i> . For <i>None</i> and <i>STARTTLS</i> , the default value is 25. For <i>SMTPS</i> , the default value is 465. <hr/>
Authentication	If required by the email server, enable authentication. If enabled, enter the <i>Username</i> and <i>Password</i> .
Security Mode	Set the connection security mode used by the email server: <ul style="list-style-type: none"> • <i>None</i> • <i>SMTPS</i> (default) • <i>STARTTLS</i>
Sender	Enter the email address used to send emails. <hr/>  For the email to be sent, depending on the <i>SMTP Server</i> used and <i>Authentication</i> being enabled, the <i>Sender</i> email address may be required to be a specific email address. <hr/>  If the <i>Sender</i> email address is incorrect, the email is not sent. <hr/>

Default Reply To

Optionally, enter the reply to email address, such as `noreply@example.com`.

This address will override the *Email from* email address that is configured for an alert email. See [Email alert settings on page 302](#).

*Other General Settings pane***Login Disclaimer**

Enable/disable displaying a disclaimer message once a user successfully logs in.

Once enabled, enter a disclaimer in the text box. Alternatively, you can use the default login disclaimer.

Last Successful Login displays when the last successful login has occurred.

Last Failed Login displays when the last failed login has occurred.

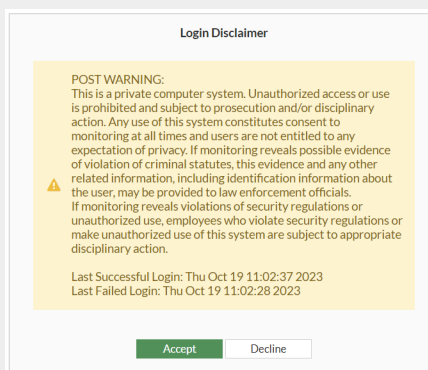

Click the eye icon to preview the login disclaimer.

Note: The option is disabled by default.

GUI Session Timeout

Select from the following two options:

- *Idle*: Enforce timeout after the entered time in *Idle in* has elapsed, in minutes (default = 5, 1 - 480).
- *Always*: Enforce user logout after the entered time in *Force logout in* has elapsed, in minutes (default = 480, 5 - 480).



A shorter *GUI Session Timeout* duration is more secure.

Concurrent Log-on

A concurrent session occurs when multiple users access FortiPAM using the same account from different locations or web browsers.

Select from the following two options:

- *Enable*: Enable user concurrent login.
- *Disable*: Disable user concurrent login.

Note: The option is disabled by default.



Once disabled, concurrent logins are disallowed.

Advanced tab

PAM Settings pane

PAM Settings

Enforce recording on glass breaking

In glass breaking mode, the administrator has permission to launch all secrets. This setting is to enforce video recording on all launching sessions (default = enable).

Live Recording

Enable/disable live recording (default = disable).



Before downgrading from FortiPAM version 1.2.x to 1.1.x, disable *Live Recording*. Otherwise, you cannot replay videos on FortiPAM 1.1.x.

See [Over-the-shoulder monitoring \(Live recording\)](#) on page 275.

Video Storage Limit

The maximum percentage of the video disk partition size that can be used for storing FortiPAM session video recordings (default = 90, 10 - 90).

Video Storage Mode

From the dropdown, select a PAM session video recording storage mode (default = *Rolling*):

- *Rolling*: Evict the oldest PAM video recording within the *Video Storage Time* when the video storage limit is reached.
- *Stop*: Stop storing new PAM video recordings when the disk quota is full.

Video Storage Time

The number of days for which a video is stored. Video files are removed from FortiPAM once the time has elapsed (default = 365, 0 - 36500).



Enable the toggle or enter 0 for no time limit.

Note: The option is only available when the *Video Storage Mode* is *Rolling*.

Recording Resolution

From the dropdown, select a resolution for the PAM video recordings:

- 480p
- 720p (default)
- 1080p

Recording FPS	Enter the PAM video recording frame rate (default = 2, 1 - 15).
Recording Color Depth	From the dropdown, select a color depth: <ul style="list-style-type: none"> • <i>24 Bit Color Depth</i> (default) • <i>32 Bit Color Depth</i>
Recording Key FPM	Enter the PAM video recording key frame rate per minute (default = 1, 1 - 60).
Max Launching Duration	Enter the maximum duration for all the secret launching sessions, in minutes (default = 120, 1 - 10000).
Client Port	Enter the port number that FortiPAM uses to connect to FortiClient (default = 9191, 1 - 65536).
Send Multiple Secret Requests in	When sending multiple secret request notifications to a reviewer: <ul style="list-style-type: none"> • <i>Separate Emails</i>: Send the secret request notifications as separate emails (default). • <i>Single Email</i>: Send the secret request notifications as a single email.
Period	Enter the time interval at which multiple secret request notifications are sent, in seconds (default = 60, 60 - 600). Note: The option is only available when <i>Send Multiple Secret Requests in</i> is set to <i>Single Email</i> .

4. Click *Apply*.

Testing the email service connection - example

To test the email service connection:

1. Go to *System > Settings*.
In this example, we use the default Fortinet mail server (`notification.fortinet.net`).
2. In the *Email Service* pane:
 - a. In *Default Reply To*, enter the email address that is used to send emails.
3. Click *Apply*.
To configure alert emails, see [Email alert settings on page 302](#).
4. Once the email service settings have been set up, click *Test Connection* from the top-right. The *Test Email Service Connectivity* dialog opens.

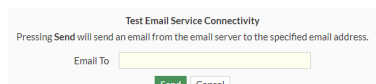

5. In *Email To*, enter an email address where the test email is sent to.
6. Click *Send*.
Once the email is successfully sent, you see the following message on the bottom-right:

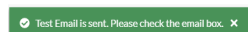

The test email looks like the following:



Test email for checking
FortiPAM email service. Inbox



noreply 3:46 PM
to me ▾



This is a test email from FortiPAM to confirm that the email service is set up correctly. If you have received this email, that means that the email service is working as intended.

To test the email service connection via the CLI:

1. In the CLI console, enter the following command:

```
diagnose log alertmail test
```

If the email service is correctly setup, you should receive a test email that looks like the following:

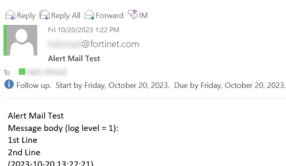

2. If you do not receive the test email:

- a. In the CLI console, enter the following CLI commands to collect the debug logs:

```
diagnose debug reset
diagnose debug enable
diagnose debug console timestamp enable
diagnose debug application alertmail -1
```

- b. In the CLI console, enter the following CLI command to send a test email:

```
diagnose log alertmail test
```

- c. In the CLI console, enter the following CLI commands to disable debugging:

```
diagnose debug disable
diagnose debug reset
```

3. To save the output, select *Download* from the top-right of the CLI window or use PuTTY to log the output.

How FortiPAM chooses the sender email address

1. FortiPAM uses the sender email address in *Log & Report > Email Alert Settings* to send alert emails.
2. FortiPAM uses the sender email address from the *Email Service* pane in *System > Settings*.

3. A concatenation of `system.email-server.user` and `system.email-server.server` (`user@server`).
4. The default email (`fortipam@fortinet.com`).

ZTNA

For an introduction to Zero Trust Network Access (ZTNA), see [Zero Trust Network Access introduction](#) in the [FortiOS Admin Guide](#).

In *System > ZTNA*, you can set up proxy rules and ZTNA tags.



ZTNA servers can only be set via the CLI (`config firewall access-proxy`).

The *ZTNA* tab looks like the following:

Proxy Rules		ZTNA Tags			
Name	From	ZTNA Control	ZTNA Tag	Access Proxy	Bytes
FortiPAM_Default	<input type="checkbox"/> any	<input checked="" type="checkbox"/> Disabled		<input checked="" type="checkbox"/> fortipam_access_proxy	1.72 MB
no_ZTNA	<input type="checkbox"/> any	<input checked="" type="checkbox"/> Disabled		<input checked="" type="checkbox"/> noztna	39.05 MB

The following options are available in all the *ZTNA* tabs:

+Create New Group	Select to create a ZTNA tag group. See Creating a ZTNA tag group on page 335
Edit	Select to edit the selected proxy rule or a tag group. See Editing a proxy rule on page 332 .
Delete	Select to delete the selected proxy rules and tag groups.
Search	Use the search bar to look for a proxy rule or a tag.
	
	To narrow down your search in the <i>ZTNA Tags</i> tabs, see Column filter .
Export	From the dropdown, select to export the list of proxy rules to your computer as a CSV file or a JSON file.
Refresh	To refresh the contents, click the refresh icon on the bottom-right. Note: The option may not be available in all the tabs.

Editing a proxy rule

A proxy rule is used to enforce access control. ZTNA tags or tag groups can be added into a rule to enforce zero trust role based access.



On the FortiPAM GUI, you can only edit an existing proxy rule. Use the CLI to create new proxy rules (`config firewall policy`).



A default *FortiPAM_Default* proxy rule is available in the proxy rules list.

To configure a proxy rule:

1. Go to *System > ZTNA*.
2. In the proxy rules list, select a proxy rule and then select *Edit*.
Alternatively, in the proxy rules list, double-click a proxy rule to edit it.

The *Edit Proxy Rule* window opens.

Statistics (since last reset)	
ID	1
Last used	3 day(s) ago
First used	3 day(s) ago
Active sessions	0
Hit count	213
Total bytes	1.72 MB
Current bandwidth	0 bps

3. Enter the following information:

Enable this rule

Toggle on to enable the proxy rule.

Name

The name of the proxy rule.



Names are not fixed and can be changed later.

Incoming Interface

Select incoming interfaces or create new interfaces.



Use the search bar to look for an interface.



Use the pen icon next to the interface to edit it.

Access Proxy

The corresponding access proxy and VIP.

The *Access Proxy* pane is read-only.**ZTNA Control**

Enable/disable ZTNA control for the proxy rule.

ZTNA control is equivalent to `client-cert` in the access proxy.**ZTNA Tag**Add the ZTNA tags or tag groups that are allowed access.
ZTNA tags are synchronized from the EMS side.

Use the search bar to look for a ZTNA tag.

[Creating a ZTNA tag group on page 335](#)**Match ZTNA tags**If multiple tags are included, select *Any* or *All* (default = *Any*).Under *Connected EMS* on the right, you can see connected EMS(s).
Hovering over one of the EMS displays a tooltip with additional details about that EMS.

- Click *OK*.

Creating a ZTNA tag group

After FortiPAM connects to the FortiClient EMS, it automatically synchronizes ZTNA tags.

ZTNA tags related information is listed in the ZTNA tags list. You can customize ZTNA tag groups to categorize user access based on multiple tags.



Hover over a tag name to see more information about the tag, such as its resolved address.

To create a ZTNA group:

- Go to *System > ZTNA* and select the *ZTNA Tags* tab.
- Select *+Create New Group*.

The *New ZTNA Tag Group* window opens.

- In *Name*, enter a name for the group.
- In *Members*, select *+*, and from the *Select Entries* window, select members or create new members.



Use the search bar to look for a member.

- Optionally, enter comments about the ZTNA tag group.
- Click *OK*.

ZTNA user control

When ZTNA control is set up on FortiPAM, you can only connect to FortiPAM and launch a secret from the endpoint PC with allowed ZTNA tags. The endpoint PC must install FortiClient and connect to the same EMS server.

To use the FortiPAM ZTNA control feature:

- You must connect to the same EMS server for the client where the FortiClient runs.
- You must enable the *ZTNA Control* option when editing a proxy rule. See [Editing a proxy rule on page 332](#).
- You must configure another access proxy with a different VIP and client certificate disabled to launch secrets without ZTNA control successfully for clients not connected to the same EMS as FortiPAM.



In FortiClient EMS 7.2.x, you must set the `<gateways_enabled>` flag to 1 to enable proxy based connections.

In FortiClient EMS 7.4.x and later, you do not need to set the `<gateways_enabled>` flag for accessing proxy based connections using FortiPAM.

To set up EMS in the GUI:

1. Go to *Network > Fabric Connectors*.
2. Select *FortiClient EMS* and click *Edit*.
3. In *Name*, enter the EMS name.
4. In *IP/Domain name*, enter the IP address or the domain name of the EMS.
5. In *HTTPS port*, enter the HTTPS port for the EMS.
6. Click *OK*.



Refer to *FortiClient EMS Status* to check the status of the FortiClient EMS.

If there is an error connecting to the EMS server, log in to the EMS server, authorize FortiPAM in *Administration > Fabric Device*, and click *Accept* in *Verify EMS Server Certificate*.

For more information, see [Fabric Connectors on page 317](#).

To set EMS using the CLI:

1. In the CLI console, enter the following commands to configure an EMS:

```
config endpoint-control fctems
  edit "ems_200"
    set server "10.59.112.200"
  next
end
```

2. After adding an EMS server, the CLI asks you to verify using `execute fctems verify ems_200`.

-example

```
execute fctems verify ems_200
Subject: C = US, ST = California, L = Sunnyvale, O = Fortinet, OU = FortiClient, CN
= FCTEMS8822002925, emailAddress = support@fortinet.com
Issuer: C = US, ST = California, L = Sunnyvale, O = Fortinet, OU = Certificate
Authority, CN = support, emailAddress = support@fortinet.com
Valid from: 2022-04-25 18:17:42 GMT
Valid to: 2038-01-19 03:14:07 GMT
Fingerprint: 35:12:95:DA:A5:2E:20:F9:8F:99:88:75:25:BC:D8:A3
Root CA: No
Version: 3
Serial Num:
a4:35:c8
Extensions:
Name: X509v3 Basic Constraints
Critical: no
Content:
CA:FALSE
```

EMS configuration needs user to confirm server certificate.

Do you wish to add the above certificate to trusted remote certificates? (y/n)y

Certificate successfully configured and verified.

If authentication is denied, log in to the EMS server and authorize FortiPAM in *Administration > Fabric Device*.

Using EMS tag for endpoint control

You can create Zero Trust tagging rules for endpoints on an EMS server based on operating system versions, logged-in domains, running processes, and other criteria. EMS uses the rules to dynamically group endpoints with different tags. FortiPAM can use these ZTNA tags in proxy rules (firewall policy) to control which endpoint has access to FortiPAM. For this, at least one FortiClient EMS must be added in *Network > Fabric Connectors*, and FortiPAM must be successfully connected to this EMS server.

FortiClient EMS is a security management solution that enables scalable and centralized management of endpoints. See [ZTNA tag control example on page 337](#).

ZTNA tag control - example

To add ZTNA tag control using the CLI:

In the access proxy, `client-cert` must be enabled. You can use `ztna-ems-tag` to give FortiPAM access to endpoints with this tag.

1. In the CLI console enter the following commands:

```
config firewall access-proxy
  edit "fortipam_access_proxy"
    set vip "fortipam_vip"
    set client-cert enable #Must be enabled
  config api-gateway
    edit 1
      set url-map "/pam"
      set service pam-service
    next
    edit 2
      set url-map "/tcp"
      set service tcp-forwarding
    config realservers
      edit 1
        set address "all"
      next
    end
  next
  edit 3
    set service gui
    config realservers
      edit 1
        set ip 127.0.0.1
        set port 80
      next
    end
  next
end
next
end
next
end
config firewall policy
  edit 1
    set type access-proxy
    set name "FortiPAM_Default"
    set srcintf "any"
```

```

set srcaddr "all"
set dstaddr "all"
set action accept
set schedule "always"
set access-proxy "fortipam_access_proxy"
set ztna-ems-tag "FCTEMS8822002925_pam-ems-tag-office" #Only endpoints with this
tag can access FortiPAM
set utm-status enable
set groups "SSO_Guest_Users"
set ssl-ssh-profile "deep-inspection"
next
end

```

ZTNA-based FortiPAM access control

When ZTNA control is enforced on FortiPAM, devices without FortiClient installed cannot access FortiPAM.



If you want to grant access to the user using the browser extension-only solution, you can create multiple proxy rules to achieve this. See [CLI configuration for a user with browser extension-only solution example on page 340](#).

Enable ZTNA control to only allow endpoints with selected tags to access FortiPAM

To enable ZTNA control:

1. Go to *System > ZTNA*.
2. In the proxy rules list, select the *FortiPAM_Default* proxy rule and then select *Edit*.
3. Enable *ZTNA Control*.
4. In *ZTNA Tag*, add the ZTNA tags or tag groups that are allowed access.



When selecting ZTNA tags, you can view all the ZTNA tags from the EMS server.

5. Click *OK*.
6. From the user dropdown on the top-right, select *Logout*.
7. When attempting to log in, a certificate check appears on the browser.
Click *OK* to proceed with logging in to FortiPAM.

CLI configuration for a user from endpoint installed with FortiClient (multiple proxy rules) - example

In this example, a user from an endpoint installed with FortiClient can access FortiPAM via VIP 192.168.1.109 provided that the endpoint contains `FCTEMS8822008307_Office_Windows_PC` or `FCTEMS8822008307_MIS_Team` ZTNA tag.

1. In the CLI console, enter the following commands:

```
config firewall vip
```

```
edit "fortipam_vip"
  set type access-proxy
  set extip 192.168.1.109
  set extintf "any"
  set server-type https
  set extport 443
  set ssl-certificate "Fortinet_SSL"
next
end
config firewall access-proxy
edit "fortipam_access_proxy"
  set vip "fortipam_vip"
  set client-cert enable
  config api-gateway
  edit 1
    set url-map "/pam"
    set service pam-service
  next
  edit 2
    set url-map "/tcp"
    set service tcp-forwarding
  config realservers
  edit 1
    set address "all"
  next
  end
next
edit 3
  set service gui
  config realservers
  edit 1
    set ip 127.0.0.1
    set port 80
  next
  end
next
end
next
end
config firewall policy
edit 1
  set type access-proxy
  set name "FortiPAM_Default"
  set srcintf "any"
  set srcaddr "all"
  set dstaddr "all"
  set action accept
  set schedule "always"
  set access-proxy "fortipam_access_proxy"
  set ztna-ems-tag "FCTEMS8822008307_Office_Windows_PC" "FCTEMS8822008307_MIS_
  Team"
  set groups "SSO_Guest_Users"
  set ssl-ssh-profile "deep-inspection"
next
end
```

CLI configuration for a user with browser extension-only solution - example

In this example, users with IP address 192.168.1.2 access FortiPAM via the VIP 192.168.1.108 from an endpoint with no FortiClient installed or no match with the ZTNA policy in the previous example.

The firewall policy is more restrictive than the previous example and allows fewer source addresses. Two VIPs are required for this setup. Also, you can set it up to allow access within a certain schedule only.

The `access-proxy` setting links to the name of the corresponding firewall access-proxy. The VIP setting links to the name of the corresponding firewall VIP. The VIP represents the FortiPAM ZTNA gateway to which clients make HTTPS connections. The service/server mappings define the virtual host matching rules and the actual server mappings of the HTTPS requests. When creating an access proxy, it is recommended to copy the default access proxy and modify only the VIP and `client-cert` settings to ensure proper configuration.

1. In the CLI console, enter the following commands:

```
config firewall vip
  edit "fortipam_vip-no-ztna"
    set type access-proxy
    set extip 192.168.1.108
    set extintf "any"
    set server-type https
    set extport 443
    set ssl-certificate "Fortinet_SSL"
  next
end
config firewall access-proxy
  edit "fortipam_access_proxy-no-ztna"
    set vip "fortipam_vip-no-ztna"
    config api-gateway
      edit 1
        set url-map "/pam"
        set service pam-service
      next
      edit 2
        set url-map "/tcp"
        set service tcp-forwarding
        config realservers
          edit 1
            set address "all"
          next
        end
      next
      edit 3
        set service gui
        config realservers
          edit 1
            set ip 127.0.0.1
            set port 80
          next
        end
      next
    end
  next
end
config firewall address
  edit "192.168.1.2"
```

```

        set subnet 192.168.1.2 255.255.255.255
    next
end
config firewall policy
    edit 2
        set type access-proxy
        set name "no ZTNA"
        set srcintf "any"
        set srcaddr "192.168.1.2"
        set dstaddr "all"
        set action accept
        set schedule "always"
        set access-proxy "fortipam_access_proxy-no-ztna"
        set groups "SSO_Guest_Users"
        set ssl-ssh-profile "deep-inspection"
    next
end

```

High availability

Multiple FortiPAM units can operate as an high availability (HA) cluster to provide even higher reliability.

FortiPAM can operate in Active-Passive HA mode.

Active-Passive: Clustered fail-over mode where all of the configuration is synchronized between the devices.

PAM configurations, such as users and secrets, are automatically synced to secondary devices to ensure PAM services can be operated or recovered when the primary device is down. All tasks are handled by the primary device as long as system events and logs are only recorded on the primary device.

Your FortiPAM device can be configured as a standalone unit, or you can configure up to three FortiPAM devices in HA, one Active and up to two Passive mode devices, for failover protection and/or disaster recovery.



HA requires an additional license for each cluster unit with the same number of seats as you have for the primary FortiPAM. Each FortiPAM device in HA must be the same device model and version number.



Logs recorded in HA are not synchronized between the primary and the secondary unit's disks. Further, secret videos recorded in HA mode are not available from FortiAnalyzer. FortiPAM displays the device's serial number that exclusively contains the log records.

The following shows FortiPAM devices in Active-Passive mode:

Status	Priority	Hostname	Serial No.	Role	System Uptime	Sessions	Throughput
Synchronized	129	FPXVM20220211006	FPXVM20220211006	Primary	4d 23h	0	4.55 Mbps
Synchronized	128	FPAVM20221206010	FPAVM20221206010	Secondary	4d 22h	0	19.00 kbps

Status, priority, hostname, serial number, role, system uptime, sessions, and throughput are displayed for each unit in the HA cluster.



- Click *Refresh* to fetch the latest information on the HA topology in use.
- Select a FortiPAM unit and select *Remove device from HA cluster* to remove the FortiPAM unit from the HA cluster.
- To edit a FortiPAM unit in an HA cluster, select the FortiPAM unit and then select *Edit*.



The primary unit in an Active-Passive cluster cannot be removed from the cluster.



Before configuring an HA cluster, ensure that interfaces are not using the DHCP mode to get IP addresses.

Configuring HA and cluster settings

To configure HA and cluster settings:

1. Go to *System > HA*.
2. Configure the following settings:

Mode	<p>From the dropdown, select <i>Standalone</i> or <i>Active-Passive</i>.</p> <hr/> <div style="display: flex; align-items: center;"> <p>If you select <i>Standalone</i>, no other options are displayed.</p> </div>
Device priority	<p>You can set a different device priority for each cluster member to control the order in which cluster units become the primary unit (HA primary) when the primary unit fails. The device with the highest device priority becomes the primary unit (default = 128, 0 - 255).</p> <hr/> <div style="display: flex; align-items: center;"> <p>Since all videos and logs are only stored on the primary device, one FortiPAM should be configured with higher priority. And with override enabled, the primary unit with the highest device priority will always become the primary unit.</p> </div> <hr/> <div style="display: flex; align-items: center;"> <p>The override setting and device priority value are not synchronized to all cluster units. You must enable override and adjust device priority manually and separately for each cluster unit.</p> </div>

Cluster Settings**Group name**

Enter a name to identify the cluster.

Password

Select *Change* to enter a password to identify the HA cluster. The maximum password length is 15 characters. The password must be the same for all cluster FortiPAM units before the FortiPAM units can form the HA cluster. It is suggested that you add a password to protect the HA cluster



Each HA cluster device on the same network must have different passwords.

Monitor interfaces

Select the specific ports to monitor or create new interfaces.



Use the search bar to look for an interface.



Use the pen icon next to the interface to edit it.

If a monitored interface fails or is disconnected from its network, the interface leaves the cluster and a link failover occurs. The link failover causes the cluster to reroute the traffic being processed by that interface to the same interface of another cluster that still has a connection to the network. This other cluster becomes the new primary unit.

Heartbeat interfaces

Select to enable or disable the HA heartbeat communication for each interface in the cluster and then set the heartbeat interface priority. You can also create new interfaces.



Use the search bar to look for an interface.



Use the pen icon next to the interface to edit it.

The heartbeat interface with the highest priority processes all heartbeat traffic. You must select at least one heartbeat interface. If the interface functioning as the heartbeat fails, the heartbeat is transferred to another interface configured as a heartbeat interface. If heartbeat communication is interrupted, the cluster stops processing traffic. Priority ranges from 0 to 512.



Heartbeat interfaces should use dedicated interfaces and not share the VIP interface.

Management Interface Reservation

Enable or disable the management interface reservation.

Note: The option is disabled by default.

You can provide direct management access to individual cluster units by reserving a management interface as part of the HA configuration. After this management interface is reserved, you can configure a different IP address, administrative access, and other interface settings for this interface for each cluster unit. You can also specify static routing settings for this interface. Then by connecting this interface of each cluster unit to your network, you can manage each cluster unit separately from a different IP address.



Only by using SSH can you access a FortiPAM node via HA management interface reservation.

Interface

Select the management interface or create a new interface.



Use the search bar to look for an interface.



Use the pen icon next to the interface to edit it.



Management interfaces should use dedicated interfaces.

Gateway

Enter the IPv4 address for the remote gateway.

IPv6 gateway

Enter the IPv6 address for the remote gateway.

Destination subnet

Enter the destination subnet.

Unicast Status

There are two options for setting up the HA heartbeat: unicast and broadcast.

Broadcast is the default HA heartbeat configuration. However, the broadcast configuration is not ideal for the VM platform because it requires special host settings. In most cases, the unicast configuration is preferable.

Enable the unicast HA heartbeat in virtual machine (VM) environments that do not support broadcast communication.

Note: The option is disabled by default.

Note: The pane is only available when the *Mode* is *Active-Passive*.



When disabling this option to change from HA unicast to broadcast, you must reboot all units in the cluster for the change to take effect.

When the broadcast mode is used, as a best practice, isolate the heartbeat devices from the user network by connecting the heartbeat devices to a dedicated switch not connected to any network.

The heartbeat packet contains sensitive information about the cluster configuration and may use a considerable amount of bandwidth.

If the cluster consists of two FortiPAM devices, connect the heartbeat device interfaces back to back using a crossover cable.

If there are more than two FortiPAM devices, each heartbeat interface should be connected to a dedicated switch. For example, in a three member HA cluster with two heartbeat interfaces, there are two switches, one switch dedicated to each interface.

Peer IP

Enter the IP address of the HA heartbeat interface of the other FortiPAM-VM in the HA cluster.

Note: The option is only available when *Unicast Heartbeat* is enabled.

Override

Enable to use the primary server by default whenever it is available.

Note: The option is enabled by default.

3. Click OK.

HA failover

When primary FortiPAM is down, secondary will take the primary role and permanently enter maintenance mode. Under maintenance mode, all critical processes will be temporarily suspended. Admin can bring up the original primary device or disable maintenance mode on the new primary device to resume all FortiPAM features.

HA active-passive cluster setup

An HA Active-Passive (A-P) cluster can be set up using the GUI or CLI.

This example uses the following network topology:

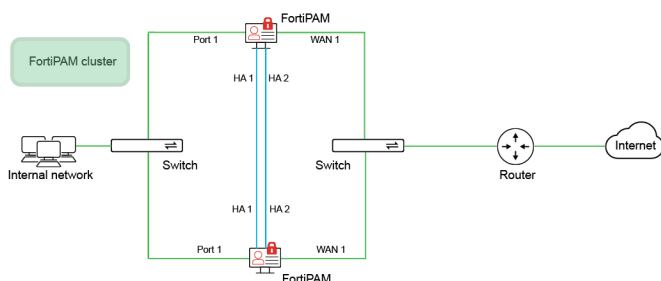

To set up an HA A-P cluster using the GUI:

1. Make all the necessary connections as shown in the topology diagram.
2. Log into one of the FortiPAM devices.

- Go to *System > HA* and set the following options:

Mode	<i>Active-Passive.</i>
Device priority	128 or higher.
Group name	Example_cluster.
Heartbeat interfaces	ha1 and ha2.



Except for the device priority, these settings must be the same on all FortiPAM devices in the cluster.

- Leave the remaining settings on default. They can be changed after the cluster is in operation.
- Click **OK**.



The FortiPAM negotiates to establish an HA cluster. Connectivity with the FortiPAM may be temporarily lost.

- Factory reset the other FortiPAM that will be in the cluster, configure GUI access, then repeat steps 1 to 5, omitting setting the device priority, to join the cluster.

To set up an HA A-P cluster using the CLI:

- Make all the necessary connections as shown in the topology diagram.
- Log into one of the FortiPAM devices.
- Change the host name of the FortiPAM:

```
config system global
  set hostname Example1_host
end
```



Changing the host name makes it easier to identify individual cluster units in the cluster operations.

- Enable HA

```
config system ha
```

```
set mode active-passive
set group-name Example_cluster
set hbdev ha1 10 ha2 20
end
```

5. Leave the remaining settings as their default values. They can be changed after the cluster is in operation.
6. Repeat steps 1 to 5 on the other FortiPAM devices to join the cluster, giving each device a unique hostname.

Upgrading FortiPAM devices in an HA cluster

You can upgrade the firmware on an HA cluster in the same way as on a standalone FortiPAM. During a firmware upgrade, the cluster upgrades the primary unit and all of the secondary units to the new firmware image.



Before upgrading a cluster, back up your configuration. See [Backup and restore on page 23](#).

Uninterrupted upgrade

An uninterrupted upgrade occurs without interrupting communication in the cluster.

To upgrade the cluster firmware without interrupting communication, the following steps are followed. These steps are transparent to the user and the network, and might result in the cluster selecting a new primary unit.

1. The administrator uploads a new firmware image using the GUI or CLI. See [Uploading a firmware on page 22](#).
2. The firmware is upgraded on all of the secondary units.
3. A new primary unit is selected from the upgraded secondary units.
4. The firmware is upgraded on the former primary unit.
5. Primary unit selection occurs, according to the standard primary unit selection process.

If all of the secondary units crash or otherwise stop responding during the upgrade process, the primary unit will continue to operate normally, and will not be upgraded until at least one secondary rejoins the cluster.

Interrupted upgrade

An interrupted upgrade upgrades all cluster members at the same time. This takes less time than an uninterrupted upgrade, but it interrupts communication in the cluster.



Interrupted upgrade is disabled by default.

To enable interrupted upgrade:

```
config system ha
set uninterruptible-upgrade disable
end
```

Disaster recovery

FortiPAM supports adding a disaster recovery node in a remote site. It uses HA to implement this feature.



Disaster recovery can only be set up using the CLI commands.

The HA primary and secondary nodes are set up in a location while HA disaster recovery node is set up in a remote location. The 3 nodes form an HA cluster.

On the disaster recovery node, use the following CLI command to enable it:

```
config system ha
  set disaster-recovery-node enable
end
```

HA primary node - CLI example

```
config system ha
  set override enable
  set priority 200
  set unicast-status enable
  set unicast-gateway 10.1.2.33
config unicast-peers
  edit 35
    set peer-ip 10.1.3.35
  next
  edit 37
    set peer-ip 10.1.2.37
  next
end
```

HA secondary node - CLI example

```
config system ha
  set override enable
  set priority 100
  set unicast-status enable
  set unicast-gateway 10.1.2.33
config unicast-peers
  edit 35
    set peer-ip 10.1.3.35
  next
  edit 36
    set peer-ip 10.1.2.36
  next
end
```

Disaster recovery node - CLI example

```
config system ha
  set override enable
  set disaster-recovery-node enable
  set unicast-status enable
  set unicast-gateway 10.1.3.33
config unicast-peers
  edit 36
    set peer-ip 10.1.2.36
```

```

next
edit 37
    set peer-ip 10.1.2.37
next
end

```



The disaster recovery node has a lower heartbeat interval, in ms (default = 600).

Use the following CLI command to change the interval:

```

config system ha
    set disaster-recovery-hb-interval <integer>
end

```

A disaster recovery node on a remote site is most likely under a different network segment from the primary. You must configure different interface IP, VIP, and gateway for the disaster recovery node based on the network design. In this case, the below setting should be configured. So that the VIP, system interface, static route, SAML server, and FortiToken Mobile push configuration among the primary, secondary, and disaster recovery nodes do not sync. When HA fails over to the disaster recovery node, FortiPAM can operate on the disaster recovery node's VIP as long as other services.

```

config system vdom-exception
edit 1
    set object firewall.vip
next
edit 2
    set object system.interface
next
edit 3
    set object router.static
next
edit 4
    set object user.saml
next
edit 5
    set object system.ftm-push
next
end

```



If you do wish to sync the above settings from the primary to the secondary, you need to edit them on the secondary manually.

When HA primary, secondary, and disaster recovery nodes use different VIPs, they must be added individually as service providers on a SAML server. And the SAML server configurations on FortiPAM HA members are also different.

Certificates

Go to *System* > *Certificates* to manage certificates.

Name	Subject	Comments	Issuer	Expires	Status	Source
Local CA Certificate						
Fortinet_CA_SSL	C = US, ST = California, L = Sunnyvale, O = Fortinet, OU = Certificate Aut...	This is the default CA certificate the SSL Inspection will use when genera...	Fortinet	2032/08/30 11:02:36	Valid	Factory
Fortinet_CA_Untrusted	C = US, ST = California, L = Sunnyvale, O = Fortinet, OU = Certificate Aut...	This is the default CA certificate the SSL Inspection will use when genera...	Fortinet	2032/07/05 17:03:49	Valid	Factory
Local Certificate						
Fortinet_Factory	C = US, ST = California, L = Sunnyvale, O = Fortinet, OU = FortiProxy, CN = ...	This certificate is embedded in the hardware at the factory and is unique ...	Fortinet	2056/01/18 19:14:07	Valid	Factory
Fortinet_Factory_Backup	C = US, ST = California, L = Sunnyvale, O = Fortinet, OU = FortiProxy, CN = ...	This certificate is embedded in the hardware at the factory and is unique ...	Fortinet	2038/01/18 19:14:07	Valid	Factory
Fortinet_SSL	C = US, ST = California, L = Sunnyvale, O = Fortinet, OU = FortiGate, CN = ...	This certificate is embedded in the hardware at the factory and is unique ...	Fortinet	2024/12/02 10:02:36	Valid	Factory
Fortinet_SSL_DSA1024	C = US, ST = California, L = Sunnyvale, O = Fortinet, OU = FortiGate, CN = ...	This certificate is embedded in the hardware at the factory and is unique ...	Fortinet	2024/12/02 10:02:38	Valid	Factory
Fortinet_SSL_DSA2048	C = US, ST = California, L = Sunnyvale, O = Fortinet, OU = FortiGate, CN = ...	This certificate is embedded in the hardware at the factory and is unique ...	Fortinet	2024/12/02 10:02:38	Valid	Factory
Fortinet_SSL_ECDSA256	C = US, ST = California, L = Sunnyvale, O = Fortinet, OU = FortiGate, CN = ...	This certificate is embedded in the hardware at the factory and is unique ...	Fortinet	2024/12/02 10:02:38	Valid	Factory
Fortinet_SSL_ECDSA384	C = US, ST = California, L = Sunnyvale, O = Fortinet, OU = FortiGate, CN = ...	This certificate is embedded in the hardware at the factory and is unique ...	Fortinet	2024/12/02 10:02:38	Valid	Factory
Fortinet_SSL_ECDSA512	C = US, ST = California, L = Sunnyvale, O = Fortinet, OU = FortiGate, CN = ...	This certificate is embedded in the hardware at the factory and is unique ...	Fortinet	2024/12/02 10:02:38	Valid	Factory
Fortinet_SSL_ED448	C = US, ST = California, L = Sunnyvale, O = Fortinet, OU = FortiGate, CN = ...	This certificate is embedded in the hardware at the factory and is unique ...	Fortinet	2024/12/02 10:02:38	Valid	Factory
Fortinet_SSL_ED25519	C = US, ST = California, L = Sunnyvale, O = Fortinet, OU = FortiGate, CN = ...	This certificate is embedded in the hardware at the factory and is unique ...	Fortinet	2024/12/02 10:02:38	Valid	Factory
Fortinet_SSL_RSA1024	C = US, ST = California, L = Sunnyvale, O = Fortinet, OU = FortiGate, CN = ...	This certificate is embedded in the hardware at the factory and is unique ...	Fortinet	2024/12/02 10:02:36	Valid	Factory
Fortinet_SSL_RSA2048	C = US, ST = California, L = Sunnyvale, O = Fortinet, OU = FortiGate, CN = ...	This certificate is embedded in the hardware at the factory and is unique ...	Fortinet	2024/12/02 10:02:36	Valid	Factory
Fortinet_SSL_RSA4096	C = US, ST = California, L = Sunnyvale, O = Fortinet, OU = FortiGate, CN = ...	This certificate is embedded in the hardware at the factory and is unique ...	Fortinet	2024/12/02 10:02:38	Valid	Factory
Fortinet_WiFi	C = US, ST = California, L = Sunnyvale, O = "Fortinet, Inc.", CN = auth-cert...	This certificate is embedded in the firmware and is the same on every unli...	DigiCert Inc	2021/12/25 15:59:59	Expired	Factory
Remote CA Certificate						
Fortinet_CA	C = US, ST = California, L = Sunnyvale, O = Fortinet, OU = Certificate Aut...		Fortinet	2056/05/27 13:27:39	Valid	Factory
Fortinet_CA_Backup	C = US, ST = California, L = Sunnyvale, O = Fortinet, OU = Certificate Aut...		Fortinet	2038/01/19 14:34:39	Valid	Factory
Fortinet_Sub_CA	C = US, ST = California, L = Sunnyvale, O = Fortinet, OU = Certificate Aut...		Fortinet	2056/05/27 13:48:33	Valid	Factory
Fortinet_WiFi_CA	C = US, O = DigiCert Inc, CN = DigiCert TLS RSA SHA256 2020 CA1		DigiCert Inc	2030/09/23 16:59:59	Valid	Factory

There are three types of certificates that FortiPAM uses:

- **Local certificates:** Local certificates are issued for a specific server or web site. Generally they are very specific and often for an internal enterprise network.
- **CA certificates:** External CA certificates are similar to local certificates, except they apply to a broader range of addresses or to whole company. A CA certificate would be issued for an entire web domain, instead of just a single web page. External CA certificates can be deleted, downloaded, and their details can be viewed, in the same way as local certificates.
- **Remote certificates:** These remote certificates are public certificates without private keys. They can be deleted, imported, and downloaded, and their details can be viewed in the same way as local certificates.

The *Certificates* tab contains the following options:

+Create/Import	From the dropdown, select <i>Certificate</i> , <i>Generate CSR</i> , <i>CA Certificate</i> , <i>Remote Certificate</i> , and <i>CRL</i> . See: <ul style="list-style-type: none"> • Creating a certificate on page 351 • Generating a CSR (Certificate Signing Request) on page 353 • Importing CA certificate on page 356 • Uploading a remote certificate on page 357 • Importing a CRL (Certificate revocation list) on page 357
Edit	Select to edit the selected certificate.
Delete	Select to delete the selected certificates.
View Details	Select to see details about the selected certificate.
Download	Select to download the selected certificate.
Search	Use the search bar to look for a certificate.

Creating a certificate

To create a certificate

1. Go to *System > Certificates*.
2. From *+Create/Import*, select *Certificate*.
The *Create Certificate* wizard opens.

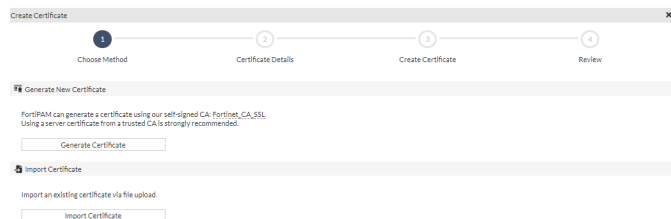

3. Enter the following information:

Choose Method**Generate New Certificate**

Select *Generate Certificate* to generate a certificate using the self-signed Fortinet_CA_SSL CA.



Using a server certificate from a trusted CA is strongly recommended.

Import Certificate

Select *Import Certificate* to import an existing certificate by uploading the file.

Certificate Details

Enter the certificate details and click *Create* to create a certificate.

Generate New Certificate**Certificate authority**

The certificate authority.

Note: The option is only available when the *Chosen Method* is *Generate New Certificate*.

Certificate name

The certificate name.

Common name

The common name of the certificate. Enter an FQDN or an IPv4 address.



The common name should match the FQDN or the IP address of the primary SSL-VPN interface.

Note: The option is only available when the *Chosen Method* is *Generate New Certificate*.

Subject alternative name

An IP address or FQDN.

Subject alternative names (SAN) allow you to protect multiple host names with a single SSL certificate. SAN is part of the X.509 certificate standard.

Note: The option is only available when the *Chosen Method* is *Generate New Certificate*.

Update Your List of Trusted Certificate Authorities

Select *Download CA Certificate* to download Fortinet_CA_SSL CA to your computer.



Fortinet_CA_SSL is a local CA certificate. To avoid certificate warnings, you must download it and install it on each client machine.

Note: The option is only available when the *Chosen Method* is *Generate New Certificate*.

Import Certificate**Type**

Select from the following three options:

	<ul style="list-style-type: none"> • <i>Local Certificate</i> • <i>PKCS #12 Certificate</i> • <i>Certificate</i> <p>Note: The option is only available when the <i>Chosen Method</i> is <i>Import Certificate</i>.</p>
Certificate file	Select <i>+Upload</i> and locate the certificate file on your local computer. Note: The option is only available when the <i>Chosen Method</i> is <i>Import Certificate</i> and the <i>Type</i> is either <i>Local Certificate</i> or <i>Certificate</i> .
Certificate with key file	Select <i>+Upload</i> and locate the certificate with key file on your local computer. Note: The option is only available when the <i>Chosen Method</i> is <i>Import Certificate</i> and the <i>Type</i> is <i>PKCS #12 Certificate</i> .
Password	Enter the password. Note: The option is only available when the <i>Chosen Method</i> is <i>Import Certificate</i> and the <i>Type</i> is either <i>PKCS #12 Certificate</i> or <i>Certificate</i> .
Confirm Password	Reenter the password to confirm. Note: The option is only available when the <i>Chosen Method</i> is <i>Import Certificate</i> and the <i>Type</i> is <i>PKCS #12 Certificate</i> or <i>Certificate</i> .
Key file	Select <i>+Upload</i> and locate the key file on your local computer. Note: The option is only available when the <i>Chosen Method</i> is <i>Import Certificate</i> and the <i>Type</i> is <i>Certificate</i> .
Review	
Update Your List of Trusted Certificate Authorities	If you have not already downloaded the <code>Fortinet_CA_SSL</code> CA to your computer, select <i>Download CA Certificate</i> to download it. Note: The option is only available when the <i>Chosen Method</i> is <i>Generate New Certificate</i> .

4. Click **OK**.

Generating a CSR (Certificate Signing Request)

Whether you create certificates locally or obtain them from an external certificate service, you need to generate a Certificate Signing Request (CSR).

When a CSR is generated, a private and public key pair is created for FortiPAM. The generated request includes the public key of the device, and information such as the unit's public static IP address, domain name, or email address. The device private key remains confidential on the unit.

After the request is submitted to a CA, the CA verifies the information and register the contact information on a digital certificate that contains a serial number, an expiration date, and the public key of the CA. The CA then signs the certificate, after which you can install the certificate on FortiPAM.

To generate a CSR:

1. Go to *System > Certificates*.
2. From *+Create/Import*, select *Generate CSR*.

The *Generate Certificate Signing Request* window opens.

Generate Certificate Signing Request

Certificate Name

Subject Information

ID Type **Host IP** Domain Name E-Mail

IP

Optional Information

Organization Unit

Organization

Locality(City)

State / Province

Country / Region

E-Mail

Subject Alternative Name

Password for private key



Key Type **RSA** Elliptic Curve

Key Size 1024 Bit 1536 Bit **2048 Bit** 4096 Bit

Enrollment Method **File Based** Online SCEP

OK Cancel

3. Enter the following information:

Certificate Name	Enter a unique name for the certificate request, such as the host name or the serial number of the device.
	 <p>Do not include spaces in the certificate to ensure compatibility as a PKCS12 file.</p>
Subject Information	
ID Type	<p>Select the ID type:</p> <ul style="list-style-type: none"> • <i>Host IP</i>: Select if the unit has a static IP address. Enter the device IP address in the <i>IP</i> field (default). • <i>Domain Name</i>: Enter the device domain name or FQDN in the <i>Domain Name</i> field. • <i>E-mail</i>: Enter the email address of the device administrator in the <i>E-mail</i> field.
Optional Information	Optional information to further identify the device.
Organizational Unit	The name of the department.
	 <p>Up to 5 OUs can be added.</p>
Organization	The legal name of the company or organization.
Locality (City)	The name of the city where the unit is located.
State/Province	The name of the state or province where the unit is located.
Country/Region	Enable and then enter the country where the unit is located. Select from the dropdown.
	 <p>The option is disabled by default.</p>
E-mail	The contact email address.
Subject Alternative Name	<p>One or more alternative names, separated by commas, for which the certificate is also valid.</p> <p>An alternative name can be: email address, IP address, URI, DNS name, or a directory name.</p> <p>Each name must be preceded by its type, for example: IP:1.2.3.4, or URL: http://your.url.here/.</p>
Password for private key	The password for the private key.

Key Type	Select <i>RSA</i> or <i>Elliptic Curve</i> . Note: The default is <i>RSA</i> .
Key Size	If you selected <i>RSA</i> for the <i>Key Type</i> , select the <i>Key size</i> : <i>1024 Bit</i> , <i>1536 Bit</i> , <i>2048 Bit</i> (default), or <i>4096 Bit</i> .
	 <p>Larger key sizes are more secure but slower to generate.</p>
	If you selected <i>Elliptic Curve</i> for the <i>Key Type</i> , select the <i>Curve Name</i> : <i>secp256r1</i> (default), <i>secp384r1</i> , or <i>secp521r1</i> .
Enrollment Method	Select the enrollment method. <ul style="list-style-type: none"> • <i>File Based</i>: Generate the certificate request (default). • <i>Online SCEP</i>: Obtain a signed, Simple Certificate Enrollment Protocol (SCEP) based certificate automatically over the network. Enter the CA server URL and challenge password in their respective fields.

4. Click *OK*.

Importing CA certificate

CA root certificates are similar to local certificates, however they apply to a broader range of addresses or to whole company; they are one step higher up in the organizational chain. Using the local certificate example, a CA root certificate would be issued for all of `www.example.com` instead of just the smaller single web page.

You can import a CA certificate to FortiPAM.

To import a CA certificate:

1. Go to *System > Certificates*.
2. From *+Create/Import*, select *CA Certificate*.
The *Import CA Certificate* window opens.

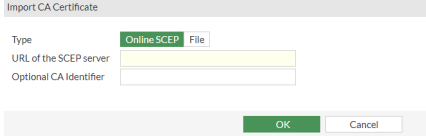

- Enter the following information:

Type	Select either <i>Online SCEP</i> or <i>File</i> .
URL of the SCEP server	The URL of the SCEP server. Note: The option is only available when the <i>Type</i> is <i>Online SCEP</i> .
Optional CA Identifier	Optionally, enter the CA identifier. Note: The option is only available when the <i>Type</i> is <i>Online SCEP</i> .
+Upload	Select and locate the certificate file on your computer. Note: The option is only available when the <i>Type</i> is <i>File</i> .

- Click *OK*.

Uploading a remote certificate

Remote certificates are public certificates without a private key. Remote certificates can be uploaded to the FortiPAM unit.

To upload a remote certificate:

- Go to *System > Certificates*.
- From *+Create/Import*, select *Remote Certificate*.
The *Upload Remote Certificate* window opens.



- Select *+Upload* and locate the certificate file on your computer.
- Click *OK*.

Importing a CRL (Certificate revocation list)

Certificate revocation list (CRL) is a list of certificates that have been revoked and are no longer usable. This list includes certificates that have expired, been stolen, or otherwise compromised. If your certificate is on this list, it will not be accepted. CRLs are maintained by the CA that issues the certificates and includes the date and time when the next CRL will be issued as well as a sequence number to help ensure you have the most current version of the CRL.

CRLs can be imported to FortiPAM.

To import a CRL:

- Go *System > Certificates*.
- From *+Create/Import*, select *CRL*.
The *Import CRL* window opens.

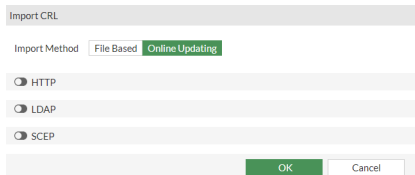

3. Enter the following information:

Imported Method Select either *File Based* or *Online Updating*.

+Upload Select and locate the certificate file on your computer.
Note: The option is only available when the *Imported Method* is *File Based*.

HTTP
 Enable HTTP updating and enter the *URL of the HTTP server*.
Note: The option disabled by default.
Note: The pane is only available when the *Imported Method* is *Online Updating*.

LDAP
 Enable LDAP updating and select an LDAP server from the dropdown or create a new one.



Use the search bar to look for an LDAP server.



Use the pen icon next to an LDAP server to edit the server.

Enter the *Username* and the *Password*.
Note: The option disabled by default.
Note: The pane is only available when the *Imported Method* is *Online Updating*.

SCEP
 Enable SCEP updating and select a local certificate or create a new certificate for SCEP communication for the online CRL.



Use the search bar to look for a certificate.

Enter the *URL of the SCEP server*.
Note: The option disabled by default.
Note: The pane is only available when the *Imported Method* is *Online Updating*.

4. Click **OK**.

Replacement messages

Replacement Messages in *System* displays a list of replacement messages.

You can customize the appearance of some web pages to fit your style requirements, e.g., the login page can be customized to include organization name and logo.

There are two types of replacement messages in FortiPAM:

- **Plain text:** Simpler customization where only the text content can be changed.
- **HTML:** Supports advanced customization.
You can customize text, re-layout or apply styles to the web components using CSS and insert images using image tags.

For every replacement message, the following columns are displayed:

- *Name*
- *Description*
- *Format*
- *Modified:* If a default replacement message is edited, a green check mark is displayed in the *Modified* column.

<input type="checkbox"/>	File Filter Block Message	Replacement text for file filter block message	text	<input checked="" type="checkbox"/>
--------------------------	---------------------------	--	------	-------------------------------------

<input type="checkbox"/>	Name	Description	Format	Modified
Admin				
<input type="checkbox"/>	Post-login Disclaimer Message	Replacement message for post-login disclaimer	text	
Authentication				
<input type="checkbox"/>	Login Page	Replacement HTML for PAM login page	html	
<input type="checkbox"/>	Login Token Page	Replacement HTML for PAM login two-factor authentication page	html	
Security Profiles				
<input type="checkbox"/>	DLP Block Page	Replacement HTML for DLP block page	html	
<input type="checkbox"/>	DLP Block Message	Replacement text for DLP block message	text	
<input type="checkbox"/>	AV Engine Load Error File Block Message	Replacement text for AV engine load error file block message	text	
<input type="checkbox"/>	File Filter Block Page	Replacement HTML for file filter block message	html	
<input type="checkbox"/>	File Filter Block Message	Replacement text for file filter block message	text	
<input type="checkbox"/>	Oversized File Block Page	Replacement HTML for oversized file block page	html	
<input type="checkbox"/>	Oversized File Block Message	Replacement text for oversized file block message	text	
<input type="checkbox"/>	Virus Outbreak Prevention Block Page	Replacement HTML for Virus Outbreak Prevention block page	html	
<input type="checkbox"/>	Virus Outbreak Prevention Block Message	Replacement text for Virus Outbreak Prevention block message	text	
<input type="checkbox"/>	AV Engine Load Error Transfer Block Message	Replacement text for AV engine load error transfer block message	text	
<input type="checkbox"/>	Oversized Transfer Block Message	Replacement text for oversized transfer block message	text	
<input type="checkbox"/>	Virus Block Page	Replacement HTML for antivirus block page	html	
<input type="checkbox"/>	Virus Block Message	Replacement text for antivirus block message	text	
Web-proxy				
<input type="checkbox"/>	Web-proxy IP Blackout Page	Replacement HTML for web-proxy IP Blackout page	html	
<input type="checkbox"/>	Web-proxy Authentication Failed Page	Replacement HTML for web-proxy authentication failed page	html	
<input type="checkbox"/>	Web-proxy Block Page	Replacement HTML for web-proxy block page	html	
<input type="checkbox"/>	Web-proxy HTTP Error Page	Replacement HTML for web-proxy HTTP error page	html	
<input type="checkbox"/>	Web-proxy ZTNA device tag block page	Replacement HTML for web-proxy ZTNA device tag block page	html	

- The following options are available in *Replacement Messages*:

Manage Images	Select to view the available images and their respective tags and add new images. By default, images are embedded in replacement messages instead of using a URL. See Managing images on page 364 .
Search	Enter a search term in the search field, then hit <code>Enter</code> to search the replacement messages list. To narrow down your search, see Column filter .
Edit	Select to edit the selected replacement message. See Editing a replacement message on page 362 .



To define a filter, see [Filters on page 25](#) in [Tables on page 25](#).



For column related settings, see [Column settings on page 28](#) in [Tables on page 25](#).

Tags

Dynamic values can be inserted to replacement message templates to provide additional information. This can be achieved by inserting tags (template variables) to the replacement message template (`%%<VARIABLE_NAME>%%`).

For example, in the *Post-login Disclaimer Message*, tags `%%LAST_SUCCESSFUL_LOGIN%%` and `%%LAST_FAILED_LOGIN%%` are present:

```
POST WARNING:
This is a private computer system. Unauthorized access or use
is prohibited and subject to prosecution and/or disciplinary
action.
...
...

%%LAST_SUCCESSFUL_LOGIN%%
%%LAST_FAILED_LOGIN%%
```

When the message is displayed to the user, these variables are replaced with the correct information.

For example:

```
POST WARNING:
This is a private computer system. Unauthorized access or use
is prohibited and subject to prosecution and/or disciplinary
action.
...
...

Last Successful Login: Thu Feb 22 13:46:28 2024
Last Failed Login: Thu Feb 22 13:46:28 2024
```

Both the HTML and the plain text template support `%%<VARIABLE_NAME>%%` variable.

Further, there is a special variable for inserting images (`%%IMAGE:<IMAGE_NAME>%%`), which can only be used in the HTML message format. When an image URL is required as part of a replacement message, the image tag can be used.



Note that when using the image tag, double quotation marks should not be used.

For example:

The following image tag is correct:

```
<img src=%%IMAGE:logo_fnet%%>
```

The following image tag is incorrect:

```

```

Another example:

```
<style>
  .logo {
    background-image: url(%%IMAGE:logo_fnet%%); #correct
  }
  .bad-logo {
    background-image: url("%%IMAGE:logo_fnet%%"); #incorrect #Don't use ""
  }
</style>
```

For information on managing images, see [Managing images on page 364](#).

Replacement messages descriptions

The following table outlines all the messages that can be customized and their descriptions.

Admin

<i>Post-login Disclaimer Message</i>	Replacement message for the post-login disclaimer.
--------------------------------------	--

Authentication

<i>Login Page</i>	Replacement HTML for the FortiPAM login page.
<i>Login Token Page</i>	Replacement HTML for the FortiPAM login two-factor authentication page.

Security Profiles

<i>DLP Block Page</i>	Replacement HTML for the DLP block page.
<i>DLP Block Message</i>	Replacement text for the DLP block message.
<i>AV Engine Load Error File Block Message</i>	Replacement text for the AV engine load error file block message.
<i>File Filter Block Page</i>	Replacement HTML for the file filter block message.

<i>File Filter Block Message</i>	Replacement text for the file filter block message.
<i>Oversized File Block Page</i>	Replacement HTML for the oversized file block page.
<i>Oversized File Block Message</i>	Replacement text for the oversized file block message.
<i>Virus Outbreak Prevention Block Page</i>	Replacement HTML for the Virus Outbreak Prevention block page.
<i>Virus Outbreak Prevention Block Message</i>	Replacement text for the Virus Outbreak Prevention block message.
<i>AV Engine Load Error Transfer Block Message</i>	Replacement text for the AV engine load error transfer block message.
<i>Oversized Transfer Block Message</i>	Replacement text for the oversized transfer block message.
<i>Virus Block Page</i>	Replacement HTML for the AntiVirus block page.
<i>Virus Block Message</i>	Replacement text for the AntiVirus block message.

Web Proxy

<i>Web-proxy IP Blackout Page</i>	Replacement HTML for the web proxy IP Blackout page.
<i>Web-proxy Authentication Failed Page</i>	Replacement HTML for the web proxy authentication failed page.
<i>Web-proxy Block Page</i>	Replacement HTML for the web proxy block page.
<i>Web-proxy HTTP Error Page</i>	Replacement HTML for the web proxy HTTP error page.
<i>Web-proxy ZTNA device tag block page</i>	Replacement HTML for the web proxy ZTNA device tag block page.

Editing a replacement message

Editor features

There are two panes in the replacement message editor in *System > Replacement Messages*:

- *Preview*
- *Editor*

Depending on the display layout that you select from the right, the panes can be hidden or arranged differently. See step 3 in [To edit a replacement message](#).

Any change that you make in the editor pane is reflected instantly in the preview pane.

The code editor supports:

- Syntax highlighting
HTML tags, attributes, embedded CSS, and embedded Javascript are colored differently to make it easier to understand the replacement message.

Variables, e.g., `%%<VARIABLE_NAME>%%` are highlighted. Variable color indicates validity, e.g., green indicates a valid variable and red indicates error, i.e., the variable was not found.

- Semantic-aware code folding
 - The replacement message code can be collapsed based on the code hierarchy.
- Hover over the HTML tag to see additional information.
 - For example, hovering over `%%<VARIABLE_NAME>%%` tag gives the example value.
 - Hovering on an image tag `%%IMAGE:logo_fnet%%` gives you a preview of the image.
- Code suggestion.
 - A suggestion is triggered when you insert a text. The suggestion includes HTML tags, attributes, and variables.
 - A suggestion pane opens when `%%` is entered. As you enter more characters the suggestion is filtered. Use up and down arrow to navigate the list. Hit enter to accept a suggestion.
- Click the arrow beside the line number to expand or collapse.
- Use *Load Default* from the top-left to restore the content to its default value.
- Use *Insert Tag* to insert `%%` at the current position of the cursor and trigger suggestions.
- User *Insert Image* to insert the image tag at the current position of the cursor and trigger suggestions.
 - The *Insert Image* button is only displayed for HTML type replacement messages.
- The *html* or *text* tag indicates the type of the message.
- *? used / ? max* indicates the current message length and the maximum message length.



A replacement message cannot exceed the maximum size.

To edit a replacement message:

1. Go to *System > Replacement Messages*.
2. In the *Replacement Messages* tab, select a message in the replacement message list and then select *Edit*. The *Edit Message* page opens.

Here, the *Login Page* replacement message was selected.

3. Edit the plain text code in the right pane.







Click the insert buttons to add variable, image tags, or:

- Enter %% to show all the available variables.
- Hit `Ctrl + Space` to display the auto-completion pane.
- Use the preview pane to preview the changes in realtime.



From the options on the right, select:

- *Preview* (): Preview the subject.
- *Editor* (): Open the plain text code editor.
- *Horizontal Split* (): Editor and preview screens are horizontally split.
- *Vertical Split* (): Editor and preview screens are vertically split.

4. To insert a tag, see [Inserting a tag](#).

5. To insert an image, see [Inserting an image](#).

6. When you are finished editing the message, select *Save* to save your changes.

7. If you have made an error when editing the message, select *Load Default* to restore the message to its default value.

See [Adding an image on page 365](#).

Managing images



To manage the images used in replacement messages, go to *System > Replacement Messages* and select *Manage Images*.

By default, the following three images are available:

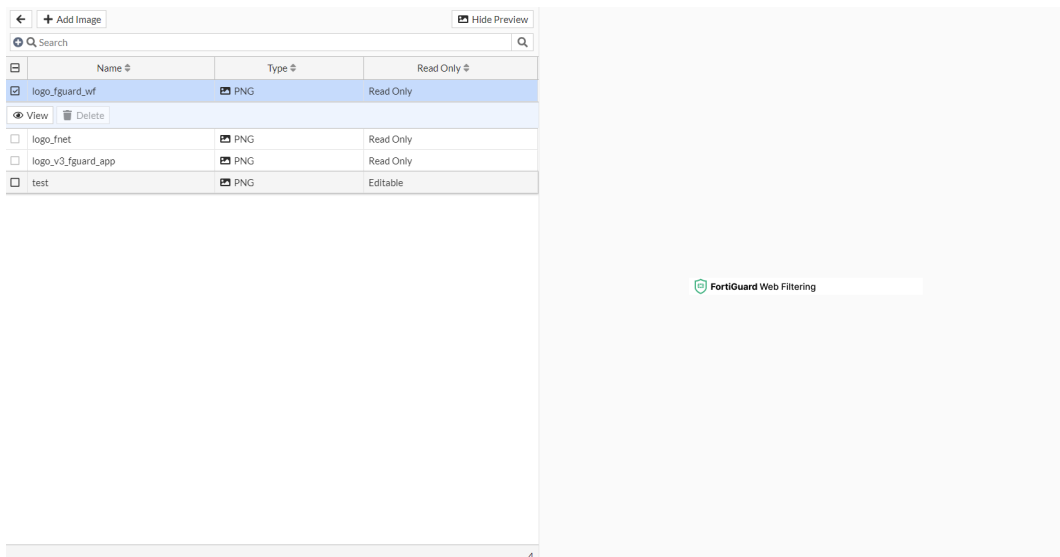
- `logo_fgward_wf`: FortiGuard Web Filtering logo.
- `logo_fnet`: Fortinet logo.
- `logo_v3_fgward_app`: Fortinet background.



In the *Managing images* page, the following options are available:

Add Image	Select to add a new image file. See Adding an image on page 365 .
Hide Preview	Select to hide the selected image preview.
Search	Enter a search term in the search field, then hit <code>Enter</code> to search the images list. To narrow down your search, see Column filter .
Edit	Select <i>Edit</i> to edit the selected image. <hr/>  The default images cannot be edited. <hr/>
View	Select <i>View</i> to view the selected default image.
Delete	Select to delete the selected images. <hr/>  The default images cannot be deleted. <hr/>

Adding an image

To add an image:

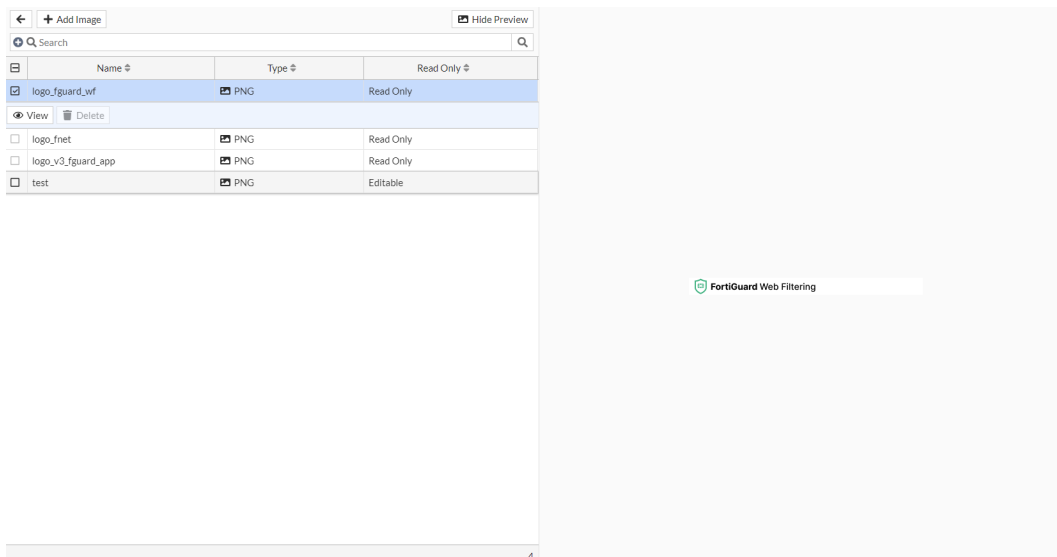

1. Go to *System > Replacement Messages* and select *Manage Images*. The *Manage Images* window opens.

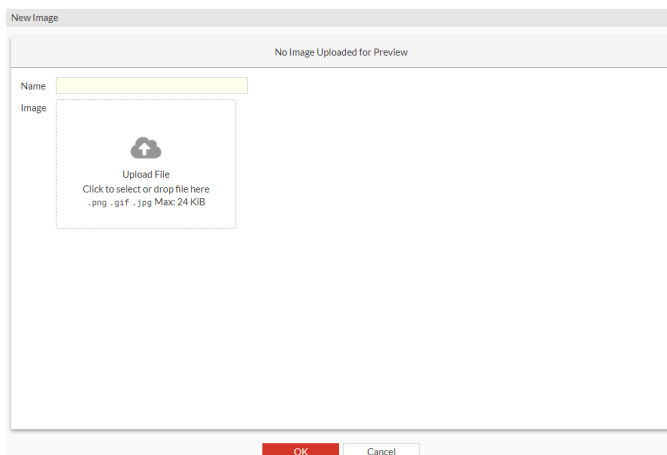

2. Select *Add Image*. The *New Image* window opens.



3. Enter the following information:

Name	The name of the image.
Image	<p>Click <i>Upload File</i>, locate the image from your computer, and click <i>Open</i>. Once the image is uploaded, you can preview it.</p> <hr/> <p> The following image file types are supported:</p> <ul style="list-style-type: none"> • .png • .gif • .jpg <hr/> <p> The maximum file size for the image is 24 KB</p>

4. Click *OK*.

To insert an image to a replacement message:

1. Go to *System > Replacement Messages*.
2. In the *Replacement Messages* tab, select a message in the replacement message list and then select *Edit*. The *Edit Message* page opens.
3. In the plain text code where you intend to add an image, select *Insert Image*. The cursor goes to `%%IMAGE :`, a list of all the images with preview appears. Alternatively, enter `%%IMAGE :`, from the dropdown, select an image, and skip to step 5.
4. Select an image from the list.
5. Click *Save*.

SNMP

The Simple Network Management Protocol (SNMP) allows you to monitor hardware on your network. You can configure the hardware, such as the FortiPAM SNMP agent, to report system information and traps.

SNMP traps alert you to events that happen, such as a log disk becoming full, or a virus being detected. These traps are sent to the SNMP managers. An SNMP manager (or host) is typically a computer running an application that can read the incoming traps and event messages from the agent and can send out SNMP queries to the SNMP agents.

By using an SNMP manager, you can access SNMP traps and data from any FortiPAM interface configured for SNMP management access. Part of configuring an SNMP manager is to list it as a host in a community on the FortiPAM unit it will be monitoring. Otherwise, the SNMP manager will not receive any traps from, and be unable to query, that FortiPAM unit.

When using SNMP, you must also ensure you have added the correct Management Information Base (MIB) files to the unit, regardless of whether or not your SNMP manager already includes standard and private MIBs in a ready-to-use, compiled database. A MIB is a text file that describes a list of SNMP data objects used by the SNMP manager. See [Fortinet MIBs on page 369](#) for more information.

The FortiPAM SNMP implementation is read-only. SNMP v1, v2c, and v3 compliant SNMP managers have read-only access to FortiPAM system information through queries and can receive trap messages from the unit.

The FortiPAM SNMP v3 implementation includes support for queries, traps, authentication, and privacy. Authentication and privacy can be configured in the CLI or the GUI.



For security reasons, Fortinet recommends that neither “public” nor “private” be used for SNMP community names.



If you want to allow SNMP access on an interface, you must go to *Network > Interfaces* and select *SNMP* in *Administrative Access* in the settings for the interface that you want the SNMP manager to connect to.

For SNMP configuration, go to *System > SNMP*.

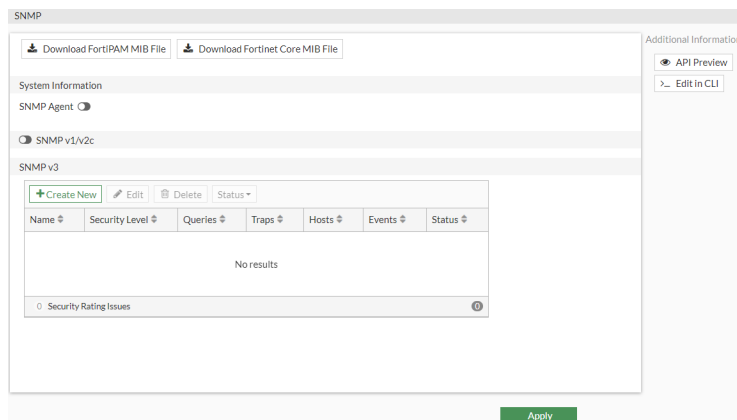



Hover over the leftmost edge of the column heading to display the *Configure Table* icon, which you can use to select the columns to display or to reset all the columns to their default settings. You can also drag column headings to change their order.

Configure the following settings and click *Apply*.

Download FortiPAM MIB File	Download the FortiPAM MIB file.
Download Fortinet Core MIB File	Download the Fortinet MIB file. See Fortinet MIBs on page 369 .
System Information	
SNMP Agent	Enable the FortiPAM SNMP agent. See SNMP agent on page 370 .
SNMP v1/v2c	
Enable to see the list of the communities for SNMP v1/v2c (disabled by default). From within this section, you can create, edit or remove SNMP communities.	
Create New	Creates a new SNMP community. When you select <i>Create New</i> , the <i>New SNMP Community</i> page opens. See Creating or editing an SNMP community on page 371 .
Edit	Modifies settings within an SNMP community. When you click <i>Edit</i> , the <i>Edit SNMP Community</i> page opens.
Delete	Removes an SNMP community from the list. To remove multiple SNMP communities, select multiple rows in the list by holding down the <code>Ctrl</code> or <code>Shift</code> keys and then select <i>Delete</i> .
Status	Enable or disable the SNMP community.
Name	The name of the community.
Queries	Indicates whether queries protocols (v1 and v2c) are enabled or disabled. A green check mark indicates that queries are enabled; a red x indicates that queries are disabled.
Traps	Indicates whether trap protocols (v1 and v2c) are enabled or disabled. A green check mark indicates that traps are enabled; a red x indicates that traps are disabled.
Hosts	List of hosts that are part of the SNMP community.
Events	Number of events that have occurred.
Status	Indicates whether the SNMP community is enabled or disabled.
SNMP v3	
Lists the SNMP v3 users. From within this section, you can edit, create or remove an SNMP v3 user.	
Create New	Creates a new SNMP v3 user. When you select <i>Create New</i> , the <i>Create New SNMP User</i> page opens. See Creating or editing an SNMP user on page 373 .
Edit	Modifies settings within the SNMP v3 user. When you click <i>Edit</i> , the <i>Edit SNMP User</i> page opens.

Delete	Removes an SNMP v3 user from the page. To remove multiple SNMP v3 users, select multiple rows in the list by holding down the Ctrl or Shift keys and then select <i>Delete</i> .
Status	Enable or disable the SNMP v3 user.
Name	The name of the SNMP v3 user.
Security Level	The security level of the user.
Queries	Indicates whether queries are enabled or disabled. A green check mark indicates that queries are enabled; a red x indicates that queries are disabled.
Traps	Indicates whether trap protocols (v1 and v2c) are enabled or disabled. A green check mark indicates that traps are enabled; a red x indicates that traps are disabled.
Hosts	List of hosts.
Events	Number of SNMP events associated with the SNMPv3 user.
Status	Indicates whether the SNMPv3 user is enabled or disabled.

Fortinet MIBs

The FortiPAM SNMP agent supports Fortinet proprietary MIBs, as well as standard RFC 1213 and RFC 2665 MIBs. RFC support includes support for the parts of RFC 2665 (Ethernet-like MIB) and the parts of RFC 1213 (MIB II) that apply to FortiPAM unit configuration.

There are two MIB files for FortiPAM units; both files are required for proper SNMP data collection:

- **Fortinet MIB:** contains traps, fields, and information that is common to all Fortinet products.
- **FortiPAM MIB:** contains traps, fields, and information that is specific to FortiPAM units.

The Fortinet MIB and FortiPAM MIB, along with the two RFC MIBs, are listed in the table in this section.

To download the MIB files, go to *System > SNMP* and select a MIB link in the SNMP section. See [SNMP on page 367](#).

Your SNMP manager may already include standard and private MIBs in a compiled database that is ready to use. You must add the Fortinet proprietary MIB to this database to have access to the Fortinet-specific information.



MIB files are updated for each version of FortiPAM. When upgrading the firmware, ensure that you update the Fortinet FortiPAM MIB file compiled in your SNMP manager as well.

MIB file name	Description
FORTINET-CORE-MIB.mib	The Fortinet MIB includes all system configuration information and trap information that is common to all Fortinet products. Your SNMP manager requires this information to monitor FortiPAM unit configuration settings and receive traps from the FortiPAM SNMP agent.

MIB file name	Description
FORTINET-FORTIPAM-MIB.mib	The FortiPAM MIB includes all system configuration information and trap information that is specific to FortiPAM units. Your SNMP manager requires this information to monitor FortiPAM configuration settings and receive traps from the FortiPAM SNMP agent. FortiManager systems require this MIB to monitor FortiPAM units.

SNMP get command syntax

Normally, to get configuration and status information for a FortiPAM unit, an SNMP manager would use an SNMP get command to get the information in a MIB field. The SNMP get command syntax would be similar to:

```
snmpget -v2c -c <community_name> <address_ipv4> {<OID> | <MIB_field>}
```

where:

- `<community_name>` refers to the SNMP community name added to the FortiPAM configuration. You can add more than one community name to a FortiPAM SNMP configuration. The most commonly used community name is public. For security reasons, Fortinet recommends that neither public nor private be used for SNMP community names.
- `<address_ipv4>` is the IP address of the FortiPAM interface that the SNMP manager connects to
- `{<OID> | <MIB_field>}` is the object identifier for the MIB field or the MIB field name itself.

For example, to retrieve the serial number of the FortiPAM device, the following command could be issued:

```
snmpget -v2c -c fortinet 192.168.1.110 1.3.6.1.4.1.12356.100.1.1.1.0
iso.3.6.1.4.1.12356.100.1.1.1.0 = STRING: "FPXVM2TM22000445"
```

In this example, the community name is fortinet, the IP address of the interface configured for SNMP management access is 192.168.1.110. The serial number of the FortiPAM device is queried using the OID:

```
1.3.6.1.4.1.12356.100.1.1.1.0.
```

SNMP agent

The FortiPAM SNMP agent must be enabled before configuring other SNMP options. Enter information about the FortiPAM unit to identify it so that when your SNMP manager receives traps from the FortiPAM unit, you will know which unit sent the information.

To configure the SNMP agent in the GUI:

1. Go to *System > SNMP*.
2. Enable *SNMP Agent*.
3. Enter a description for the agent. The description can be up to 255 characters long.
4. Enter the physical location of the unit. The system location description can be up to 255 characters long.
5. Enter the contact information for the person responsible for this FortiPAM unit. The contact information can be up to 255 characters.
6. Click *Apply* to save your changes.

To configure the SNMP agent with the CLI:

Enter the following CLI commands:

```
config system snmp sysinfo
  set status enable
  set contact-info <contact_information>
  set description <description_of_FortiPAM>
  set location <FortiPAM_location>
end
```

Creating or editing an SNMP community

An SNMP community is a grouping of devices for network administration purposes. Within that SNMP community, devices can communicate by sending and receiving traps and other information. One device can belong to multiple communities, such as one administrator terminal monitoring both a firewall SNMP and a printer SNMP community.

Add SNMP communities to your FortiPAM unit so that SNMP managers can view system information and receive SNMP traps. You can add up to three SNMP communities. Each community can have a different configuration for SNMP queries and traps and can be configured to monitor the FortiPAM unit for a different set of events. You can also add the IP addresses of up to sixteen SNMP managers to each community.

Enabling *SNMP v1/v2c* and selecting *Create New* in the *SNMP v1/v2c* pane opens the *New SNMP Community* page, which provides settings for configuring a new SNMP community. Double-clicking a community from the *SNMP v1/v2c* table opens the *Edit SNMP Community* page. Alternatively, select a community from the list and then select *Edit* to edit the SNMP community.

New SNMP Community

Community Name

Enabled

Hosts

IP Address

Host Type

IP Address

Host Type

Queries

v1 Enabled

Port

v2c Enabled

Port

Traps

v1 Enabled

Local Port

Remote Port

v2c Enabled

Local Port

Remote Port

SNMP Events

- CPU usage too high
- Available memory is low
- Available log space is low
- Interface IP address changed
- HA cluster status change
- HA heartbeat interface failure
- AV detected virus
- HA cluster member up
- HA cluster member down
- Entity config change (RFC4133)
- Disconnected from FortiAnalyzer
- Per CPU usage is high

Configure the following settings in the *New SNMP Community* page or *Edit SNMP Community* page and click *OK*:

Community Name	Enter a name to identify the SNMP community. After you create the SNMP community, you cannot edit the name.
Enabled	Enable or disable the SNMP community.
Hosts Settings for configuring the hosts of an SNMP community.	
IP Address	Enter the IP address/netmask of the SNMP managers that can use the settings in this SNMP community to monitor the unit. You can also set the IP address to 0.0.0.0 so that any SNMP manager can use this SNMP community.
Host Type	Select one of the following: <i>Accept queries and send traps</i> , <i>Accept queries only</i> , or <i>Send traps only</i> .
X	Removes an SNMP manager from the list within the <i>Hosts</i> section.
+	Select to add a blank line to the Hosts list. You can add up to 16 SNMP managers to a single community.
Queries Settings for configuring queries for both SNMP v1 and v2c.	
v1 Enabled	Enable or disable SNMP v1 queries.
Port	Enter the port number (161 by default) that the SNMP managers in this community use for SNMP v1 and SNMP v2c queries to receive configuration information from the unit. The SNMP client software and the unit must use the same port for queries.
v2c Enabled	Enable or disable SNMP v2c queries.
Traps Settings for configuring local and remote ports for both v1 and v2c.	
v1 Enabled	Enable or disable SNMP v1 traps.
Local Port	Enter the local port numbers (162 by default) that the unit uses to send SNMP v1 or SNMP v2c traps to the SNMP managers in this community. The SNMP client software and the unit must use the same port for traps.
Remote Port	Enter the remote port number (162 by default) that the unit uses to send SNMP traps to the SNMP managers in this community. The SNMP client software and the unit must use the same port for traps.
v2C Enabled	Enable or disable SNMP v2c traps.
SNMP Events Enable each SNMP event for which the unit should send traps to the SNMP managers in this community. Note: The CPU usage too high trap's sensitivity is slightly reduced by spreading values out over 8 polling cycles. This reduction prevents sharp spikes due to CPU intensive short-term events such as changing a policy.	

Creating or editing an SNMP user

Selecting *Create New* in the *SNMP v3* pane opens the *New SNMP User* page, which provides settings for configuring a new SNMP v3 user. Double-clicking a user from the *SNMP v3* table opens the *Edit SNMP User* page. Alternatively, select an SNMP user and then select *Edit* to edit the SNMP user.

The screenshot shows the 'New SNMP User' configuration window. It contains several sections:

- User Name:** A text input field.
- Enabled:** A radio button set with 'Enabled' selected.
- Security Level:** Radio buttons for 'No Authentication', 'Authentication', 'No Private', and 'Private'. 'No Authentication' is selected.
- Hosts:** A table with 'IP Address' and a search icon.
- Queries:** A radio button set with 'Enabled' selected and a 'Port' input field.
- Traps:** A radio button set with 'Enabled' selected, and 'Local Port' and 'Remote Port' input fields.
- SNMP Events:** A list of events with checkboxes, including 'CPU usage too high', 'Available memory is low', 'Interface IP address changed', etc.

 At the bottom, there are 'OK' and 'Cancel' buttons.

Configure the following settings in the *New SNMP User* page or *Edit SNMP User* page and click *OK*:

User Name

Enter the name of the user. After you create an SNMP user, you cannot change the user name.

Enabled

Enable or disable this SNMP user.

Security Level

Select the type of security level the user will have:

- *No Authentication*
- *Authentication* and *No Private*—Select the authentication algorithm and enter password to use.
- *Authentication* and *Private*—Select the authentication and encryption algorithm and enter the passwords to use.

Authentication/Encryption Algorithm

If the security level is set to *Authentication* and *No Private*, you can select from the following authentication algorithms:

- *MD5*
- *SHA1* (default)
- *SHA224*
- *SHA256*
- *SHA384*
- *SHA512*

If the security level is set to *Authentication* and *Private*, you can also select from the following encryption algorithms in addition to authentication algorithms:

- *AES* (default)
- *DES*
- *AES256*

- *AES256 Cisco*

Password

If the security level is set to *Authentication*, select *Change* and enter a password in the *Password* field.

Hosts

Settings for configuring the hosts of an SNMP community.

IP Address

Enter the IP address of the notification host. If you want to add more than one host, select + to add another host. Up to 16 hosts can be added. Select X to delete any hosts.

Queries

Settings for configuring queries for both SNMP v1 and v2c.

Enabled

Enable or disable the query. By default, the query is enabled.

Port

Enter the port number in the *Port* field (161 by default).

Traps

Settings for configuring local and remote ports for both v1 and v2c.

Enabled

Enable or disable the trap.

Local Port

Enter the local port number (162 by default).

Remote Port

Enter the remote port numbers (162 by default).

SNMP Events

Select the SNMP events that will be associated with the user.

Backup

FortiPAM configuration contains not only the system settings but also all user information and secret data. It is crucial to have a backup to avoid data loss. Whenever a hardware failure or system relocation is needed, a new FortiPAM can be easily set up by restoring the previous backup configuration. In the case of accidentally deleting data, you can retrieve the original configuration from the backup and paste the data back.

FortiPAM has two ways to back up its configuration:

- Manually trigger from the user menu. See *Backup and restore* in [Admin on page 21](#).
- Configure automatically and periodically backup to an FTP, SFTP, HTTP or HTTPS server in *System > Backup* as discussed here.



System Events, secret logs, and videos are not contained in backup configuration file.



Whenever restoring a backup configuration, keep in mind that the secret password or key may not be the most recent one.

To ensure that all credentials are correct in a configuration file, you can enable maintenance mode first so that no password changer is executed. And then manually trigger the configuration backup. See *Activate maintenance mode in Admin on page 21*.



Generally speaking, the configuration should be backed up consistently and regularly to minimize the amount of data loss between backup copies. The lesser the frequency of backup configurations, the more the risk for data loss when recovering from a backup.



To update automated backup settings:

1. Go to *System > Backup*.

The *Edit Automated backup* window opens.

2. Enter the following information:

Status	Enable or disable automatic backup. Note: The option is enabled by default.
Backup Type	Select from the following two options: <ul style="list-style-type: none"> • <i>Time based trigger</i>: FortiPAM sends the backup configuration to the server every <i>Interval</i> minutes. • <i>Change based trigger</i>: FortiPAM checks the configuration every <i>Interval</i> minutes and if the configuration has changed, FortiPAM sends it to the server (default).
Interval	The time interval required in backup, in minutes (default = 60, 60 - 4294967295).
Server Type	Select from the following server types: <ul style="list-style-type: none"> • <i>FTP server</i> (default) • <i>SFTP server</i> • <i>HTTP server</i> • <i>HTTPS server</i>

	 <p>To successfully configure an HTTP/HTTPS server to backup with user authentication, ensure that you have filled in the username and password fields. The backup process will not function correctly if you leave either field empty. Alternatively, you can leave both fields empty if you want to avoid user authentication.</p>
Encrypt File	<p>Enable and enter cipher key to encrypt the backup file.</p> <hr/>  <p>The administrator must enter the same cipher key when restoring the configuration to FortiPAM.</p> <hr/> <p>Note: The option is disabled by default.</p>
Server Address	<p>The IP address of the server.</p>
Server Path	<p>The path to store the backup file in the server.</p>
Port	<p>The port of the file server.</p> <p>Default values:</p> <ul style="list-style-type: none"> • 21 (FTP server) (default) • 22 (SFTP server) • 80 (HTTP server) • 443 (HTTPS server)
	 <p>When upgrading, the port number is set according to the server type (ftp = 21, sftp = 22, http = 80, and https = 443).</p>
Identifier Name	<p>The variable name that server uses to identify the file.</p> <p>Note: Only required for <i>HTTP/HTTPS server</i> type.</p>
Server Certificate Check	<p>Enable/disable server identity check. This verifies the server domain name/IP address against the server certificate.</p> <p>Note: The option is disabled by default.</p> <p>Note: The option is only available for <i>HTTPS server</i>.</p>
Server CA Certificate	<p>From the dropdown, select a server CA certificate for server certificate check.</p> <p>Note: The option is only available when <i>Server Certificate Check</i> is enabled.</p>
Username	<p>Username to log in to the server.</p>
Password	<p>Password to log in to the server.</p>
Filename	<p>Filename pattern of the backup configuration.</p> <p>Valid variables are: \$SN \$YYYY \$MM \$DD \$hh \$mm \$ss \$ID.</p> <p>Note: The \$ID variable is mandatory in the filename pattern</p>



Enter \$ to get the list of variables.

Limit ID

Enable to limit the value of \$ID in the file name.

The option allows administrators to set a maximum number of backup files (default = 1, 1 - 4294967295) to be stored on a backup server using specific filename patterns.

For example, if the backup filename follows the format PAM-\$SN-\$ID.conf, where \$ID represents the backup ID, when \$ID reaches the maximum limit, it is reset to 0. The new backup file overwrites the old backup file using the same name.

Last backup version

The last backup version (noneditable).

Last updated time

The date and time when automatic backup was last done (noneditable).

3. Click *Apply*.
4. Click *Test Connectivity* to test the connection to the backup server.

Configuring automated backup settings on the CLI

```
config system backup
  set status {enable | disable}
  set cipher <passwd>
  set type {time-based | change-based}
  set server-type {ftp | sftp | http | https}
  set server-address <string>
  set server-path <path>
  set port <integer>
  set file-field-name <string>
  set server-user <string>
  set server-pass <passwd>
  set filename-pattern {$SN $YYYY $MM $DD $hh $mm $ss $ID}
  set ca-cert <string>
  set server-identity-check {enable | disable}
  set interval <integer>
  set max-id <integer>
  set backup-id <integer>
  set last-version <integer>
  set updated-time <integer>
end
```

Variables	Description
status {enable disable}	Enable/disable automatic backup (default = enable).
cipher <passwd>	Enter the cipher key.
type {time-based change-based}	Set the backup type: <ul style="list-style-type: none"> • time-based: Time based trigger. • change-based: Change based trigger (default).

Variables	Description
server-type {ftp sftp http https}	Set the server type: <ul style="list-style-type: none"> ftp (default) sftp http https
server-address <string>	Enter the address of file server.
server-path <path>	Enter the path of file server (default = /).
port <integer>	Enter the port number of the file server (default = 21, 1 - 65535).
file-field-name <string>	Enter the field name for file upload (default = files).
server-user <string>	Enter the username of the server account.
server-pass <passwd>	Enter the password of the server account.
filename-pattern {\$SN \$YYYY \$MM \$DD \$hh \$mm \$ss \$ID}	Enter the file name pattern of the backup configuration (default = \$ID.conf). Note: The \$ID variable is mandatory in the filename pattern.
ca-cert <string>	Enter the CA certificate name.
server-identity-check {enable disable}	Enable/disable server identity check (verify server domain name/IP address against the server certificate) (default = disable).
interval<integer>	Enter an interval for the backup, in minutes (60 - 4294967295, default = 60).
max-id <integer>	Enter the limit for backup-id (default = 0). Note: Use 0 to set no limit.
backup-id <integer>	The current backup id number. Note: The variable cannot be modified.
last-version <integer>	The last backup version. Note: The variable cannot be modified.
updated-time <integer>	The time when the last update was done. Note: The variable cannot be modified.

Example CLI configuration - Example

Backup to SFTP/FTP server

```

config system backup
  set status enable
  set server-type sftp
  set server-address "10.59.112.254"
  set server-path "backup/"
  set port 22
  set server-user "sftp_user"
  set server-pass <sftp_user_password>
  set filename-pattern "$SN-$YYYY-$MM-$DD-$hh-$mm-$ss-$ID.conf"
end

```

Backup to HTTPS/HTTP server

```
config system backup
  set status enable
  set server-type https
  set server-address "10.59.112.254"
  set server-path "/http_user/upload.php"
  set port 443
  set file-field-name "file"
  set server-user "http_user"
  set server-pass QA@fortinet
  set filename-pattern "$SN-$ID.conf"
  set ca-cert "ACCVRAIZ1"
  set server-identity-check enable
end
```

If user authentication is not required for HTTP and HTTPS servers, `server-user` and `server-pass` variables are not required.

Following is an example of php file to accept the submitted backup file.

```
fwd-svr@fwdsvr-virtual-machine:/var/www/html/http_user$ cat upload.php
<?php
$name = $_FILES['file']['name'];
$temp = $_FILES['file']['tmp_name'];
if(move_uploaded_file($temp,"backup/".$name)){
echo "Your file was uploaded";
}
else
{
echo "Your file couldn't upload";
}
?>
```

Sending backup file to a server - Example

The example shows how an administrator can verify system backup configuration and the connection to the backup server.

To send a backup file to a server:

1. In the CLI console, enter the following commands:

```
diagnose debug enable
diagnose test application wad 1000
....
....
```

```
Process [13]: type=secret-approval(14) index=0 pid=1080 state=running
diagnosis=yes debug=enable valgrind=supported/disabled
```

2. Find the process with the `type secret-approval` and the index.
In the example above, the process type is 14 and index is 0.
3. Generate the diagnosis process using `2<process type><index>`.
In the example above, the diagnosis process is 21400.
4. Enter the following command:

```
diagnose test application wad 21400
```

Set diagnosis process: type=secret-approval index=0 pid=1080

5. Enter the following command:

```
diagnose test application wad
WAD process 1080 test usage:
```

....

```
701: Test sending file using backup config
```

6. Enter the following command:

```
diagnose test application wad 701
Sending backup to server using system.backup settings manually.
Finished sending backup to server. Check to see if backup file was successfully
uploaded.
```

Additionally, you can check *System Events* in *Log & Report > Events* to determine whether the system configuration backup process was successful.

Date/Time	Level	User	Message	Log Description	Log Details
2 minutes ago	INFO	daemon_admin	Automatic backup sent the configuration to https://10.59.112.234/backup.php	System configuration backed up	General Absolute Date/Time: 2023/02/21 10:57:17 Time: 10:57:17 Vdom: root Log Description: System configuration backed up
4 hours ago	INFO	daemon_admin	Automatic backup sent the configuration to https://10.59.112.234/backup.php	System configuration backed up	Source User: daemon_admin
2 hours ago	INFO	daemon_admin	Automatic backup sent the configuration to https://10.59.112.234/backup.php	System configuration backed up	Action Action: backup
3 hours ago	INFO	daemon_admin	Automatic backup sent the configuration to https://10.59.112.234/backup.php	System configuration backed up	Security Level: INFO
4 hours ago	INFO	daemon_admin	Automatic backup sent the configuration to https://10.59.112.234/backup.php	System configuration backed up	Event User: wad Interface: wad Message: Automatic backup sent the configuration to https://10.59.112.234/backup.php
5 hours ago	INFO	daemon_admin	Automatic backup sent the configuration to https://10.59.112.234/backup.php	System configuration backed up	Other Event Time: 1677020837644200700 Timezone: 0900 Log ID: 0100032142 Type: event Sub-Type: system
6 hours ago	INFO	daemon_admin	Automatic backup sent the configuration to https://10.59.112.234/backup.php	System configuration backed up	
7 hours ago	INFO	daemon_admin	Automatic backup sent the configuration to https://10.59.112.234/backup.php	System configuration backed up	
8 hours ago	INFO	daemon_admin	Automatic backup sent the configuration to https://10.59.112.234/backup.php	System configuration backed up	
9 hours ago	INFO	daemon_admin	Automatic backup sent the configuration to https://10.59.112.234/backup.php	System configuration backed up	
10 hours ago	INFO	daemon_admin	Automatic backup sent the configuration to https://10.59.112.234/backup.php	System configuration backed up	
11 hours ago	INFO	daemon_admin	Automatic backup sent the configuration to https://10.59.112.234/backup.php	System configuration backed up	
13 hours ago	INFO	daemon_admin	Automatic backup sent the configuration to https://10.59.112.234/backup.php	System configuration backed up	
14 hours ago	INFO	daemon_admin	Automatic backup sent the configuration to https://10.59.112.234/backup.php	System configuration backed up	
15 hours ago	INFO	daemon_admin	Automatic backup sent the configuration to https://10.59.112.234/backup.php	System configuration backed up	
16 hours ago	INFO	daemon_admin	Automatic backup sent the configuration to https://10.59.112.234/backup.php	System configuration backed up	
17 hours ago	INFO	daemon_admin	Automatic backup sent the configuration to https://10.59.112.234/backup.php	System configuration backed up	
18 hours ago	INFO	daemon_admin	Automatic backup sent the configuration to https://10.59.112.234/backup.php	System configuration backed up	
19 hours ago	INFO	daemon_admin	Automatic backup sent the configuration to https://10.59.112.234/backup.php	System configuration backed up	

Firmware

The FortiPAM firmware can be upgraded from *System > Firmware*.

The widgets at the top display:

- The total number of FortiPAM devices.
- The upgrade status of the FortiPAM devices.

The *Firmware* tab displays the device name, device status, registration status, firmware version, and the upgrade status.

Device	Status	Registration Status	Firmware Version	Upgrade Status
FPAYM20221206008	Online	Registered	v1.1.0 build0417	Up to date

The following options are available in the *Firmware* tab:

Upgrade Upgrade the FortiPAM firmware. See [Uploading a firmware on page 22](#).

Register**Authorize****Search**

Enter a search term in the search field, then hit `Enter` to search. To narrow down your search, see [Column filter](#).

Upgrading the firmware

Periodically, Fortinet issues firmware upgrades that fix known issues, add new features and functionality, and generally improve your FortiPAM experience.

Before proceeding to upgrade the system, Fortinet recommends that you back up the configuration. See [Backup and restore on page 23](#).

To be able to upgrade the firmware, you must first register your FortiPAM with Fortinet. See [Licensing on page 41](#).

To upgrade the firmware from FortiPAM GUI, see [Uploading a firmware on page 22](#).



Always review all sections in *FortiPAM Release Notes* prior to upgrading your device.

FortiPAM license

The FortiPAM-VM license can be uploaded from *System > FortiPAM License*.



You must be in maintenance mode to be able to upload a license. See [Maintenance mode in Admin on page 21](#).

To upload a new license:

1. Go to *System > FortiPAM License*.

The *FortiPAM VM License* window opens.

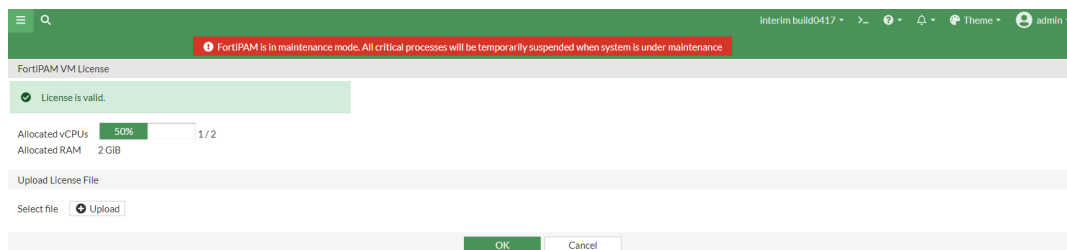

2. In the *Upload License File* pane, select *Upload* and browse to the license file on your management computer.

3. Click *OK*.
4. After the boot up, the license status changes to valid.



Use the CLI command `get system status` to verify the license status.

Stackable seat license for hardware models

For FortiPAM 1000G and 3000G hardware models, you can update the licensed seat using the provided key if you purchase a new stackable seat license with additional seats from FortiCare.

To update the license:

1. On a FortiPAM 1000G/3000G model, go to *System > FortiPAM License*. The *FortiPAM Seat License* window opens.

2. Enter the key provided by FortiCare.
3. Click *Update* to save your changes.



A warning appears if the number of seats in the new license is equal to or less than the existing license.

Click *Yes* to force the update or *No* to abort the update.

To update the license using the CLI:

1. In the CLI console, enter the following command:

```
execute upd-seat-license <key-string>
```

FortiGuard license

Go to *System > FortiGuard License* to configure FortiGuard subscription services. See [FortiGuard Distribution Network](#) on page 52.

Disclaimers via the CLI

FortiPAM allows you to set up login disclaimers.

Once you are successfully authenticated, a login disclaimer banner appears. You must click *Accept* to access FortiPAM. If you click *Decline*, you are logged out immediately.

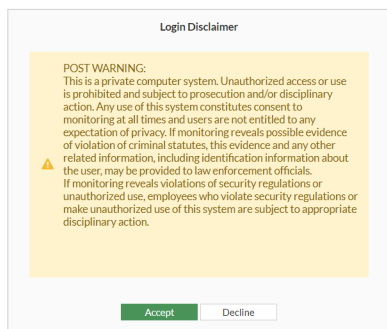

You can set up login disclaimers in the GUI using the *Login Disclaimer* toggle and the text box available in the *Other General Settings* pane in *System > Settings*.

Disclaimers via the CLI - Example

To configure a login disclaimer:

1. In the CLI console, enter the following command to enable the login disclaimer:

```
config system global
    set post-login-banner enable #display the administrator access disclaimer message
    after an administrator successfully logs in
end
```

2. In the CLI console, enter the following commands to set up the login disclaimer:

```
config system replacemsg admin post_admin-disclaimer-text
    set buffer "POST WARNING:
        This is a private computer system. Unauthorized access or use is prohibited and
        subject to prosecution and/or disciplinary action. Any use of this system
        constitutes consent to monitoring at all times and users are not entitled
        to any expectation of privacy. If monitoring reveals possible evidence of
        violation of criminal statutes, this evidence and any other related
        information, including identification information about the user, may be
        provided to law enforcement officials. If monitoring reveals violations of
        security regulations or unauthorized use, employees who violate security
        regulations or make unauthorized use of this system are subject to
        appropriate disciplinary action."
    set header none
    set format text
end
```



The disclaimer must begin and end with quotation marks.

Troubleshooting

FortiPAM operation requires multiple components to work together. Generally, a browser and FortiClient are necessary on the client side to connect to the FortiPAM GUI. Secrets on FortiPAM can then be used to connect to the target host.

If the FortiPAM system runs abnormally, pinpointing the failed component can be challenging. This chapter presents the usage of built-in debug tools to speed up finding errors.



You must have system administrator and CLI permissions to use the debug features including debug trace files. See [Role on page 243](#).



To use FortiPAM debug feature, debug category and level must be set.

In the CLI console, enter the following commands to set debug category and level:

```
diagnose wad debug enable category <category>
diagnose wad debug enable level <level>
```

For example:

```
diagnose wad debug enable category session #The category is session
diagnose wad debug enable level info #The level is set to info
```



For debug level settings, all the higher level traces are included, e.g., when the debug level is set to `info`, `error` and `warn` levels are displayed too, but `verbose` is hidden.

Once the `category` and `level` variables are set up in the CLI, traces are displayed in the CLI.



For more troubleshooting information and a Q&A section, check out the FortiPAM Community page: <https://community.fortinet.com/t5/FortiPAM/tkb-p/TKB52>.

Troubleshooting network gateways

In the CLI console, enter the following commands:

```
diagnose wad debug enable category gateway #dumps gateway config cache and the ongoing
gateway session
diagnose test application wad 426
diagnose test application wad 429
```

See troubleshooting [Issue: WebRDP session recording fails and closes active session on page 388](#).

For FortiPAM related troubleshooting tips, see [Troubleshooting Tip: General Client-side Debugging Tips/Info](#) on the [Fortinet Community](#).

Troubleshoot using trace files

To successfully capture each daemon's trace as separate log files, use FortiPAM debug trace files. You can then view each file and locate the source of an issue.



To use FortiPAM trace file debug feature, debug category and level must be set. See [Troubleshooting on page 384](#).

Related CLI commands:

Command	Description
<code>diagnose wad debug file {enable disable}</code>	Enable/disable dump trace to files.
<code>diagnose wad debug file max_size <size></code>	Set the maximum size for trace files.
<code>diagnose wad debug file overwrite {enable disable}</code>	Allow overwriting when the file reaches maximum size.
<code>diagnose wad debug file clear</code>	Clear all the trace files.
<code>diagnose wad debug file list</code>	Show all trace related file stats.
<code>diagnose wad debug file show {trace_file_name all}</code>	Show a specific or all trace file content.
<code>diagnose wad debug file send tftp <addr> <save_zip_name.tar.gz></code>	Send trace files to TFTP server.
<code>diagnose wad debug file send ftp <save_zip_name.tar.gz> <addr>: [port] [username] [password]</code>	Send trace files to FTP server.

Example troubleshooting - example

- In the CLI console, enter the following commands to set debug category and level:

```
diagnose wad debug enable category secret
diagnose wad debug enable level info
```
- Enter the following command to set the maximum size for trace files:

```
diagnose wad debug file max-size 2
```

3. Enter the following command to enable dump trace to files:

```
diagnose wad debug file enable
```

Trace file is displayed now.

4. Enter the following command to disable dump trace to files:

```
diagnose wad debug file disable
```

5. Enter the following command to show all trace related file stats:

```
diagnose wad debug file list
size:0000000000, wad_worker-1.log
size:0000000000, wad_cert-inspection-0.log
size:0000000000, wad_debug-0.log
size:0000000000, wad_algo-0.log
size:0000000000, wad_user-info-0.log
size:0000000000, wad_dispatcher-0.log
size:0000000000, wad_secret-approval-0.log
size:0000000000, wad_config-notify-0.log
size:0000000000, wad_informer-0.log
size:0000000000, wad_YouTube-filter-cache-service-0.log
size:0000006869, wad_worker-0.log
size:0000000000, wad_pwd-changer-0.log
size:0000000000, wad_manager-0.log
```

6. Enter the following command to clear all the trace files:

```
diagnose wad debug clear
```

7. Enter the following command to show a specific file content:

```
diagnose wad debug file show wad_worker-0.log
```

```
[I][p:1066][s:369910368][r:2588] wad_gui_secret_handler :4123 Successfully fetched
database list for admin
[I][p:1066][s:369910368][r:2588] wad_gui_secret_handler :4510 attach response body to
response
[I][p:1066][s:369910368][r:2590] wad_gui_secret_handler :4060 METHOD OVERRIDE to GET,
fetching list
[I][p:1066][s:369910368][r:2590] wad_gui_secret_folder_post_select :1669 Dev is NULL
[I][p:1066][s:369910368][r:2590] wad_gui_secret_folder_post_select :1715 filter gets
all personal secret folders
[I][p:1066][s:369910368][r:2590] wad_gui_secret_handler :4088 Successfully fetched
folder list for admin
[I][p:1066][s:369910368][r:2590] wad_gui_secret_handler :4510 attach response body to
response
[I][p:1066][s:369910370][r:2592] wad_gui_secret_handler :4060 METHOD OVERRIDE to GET,
fetching list
[I][p:1066][s:369910370][r:2592] wad_gui_secret_folder_post_select :1669 Dev is NULL
[I][p:1066][s:369910370][r:2592] wad_gui_secret_handler :4088 Successfully fetched
folder list for admin
.
.
```

FortiPAM HTTP filter

When turning on the HTTP category debug, it can generate a lot of traces from the GUI. In the case where GUI traffic is not needed, using the FortiPAM HTTP filter helps clean out traffic that is not required.



You must have system administrator and CLI permissions to use the FortiPAM HTTP filter.

To use the FortiPAM trace filter feature:

1. In the CLI console, enter the following command to set the debug category to http:
`diagnose wad debug enable category http`
2. Optionally, enter the following command to set the debug level:
`diagnose wad debug enable level <level>`
3. Use the following CLI command to set up a filter for the FortiPAM traffic:
`diagnose wad filter pam`

Variable	Description
none	Reset FortiPAM filter setting. All the HTTP traffic traces are displayed.
internal	Internal FortiPAM trace. HTTP traffic with <code>/pam api-gateway</code> is displayed, e.g., FortiClient and secret launcher traffic.
tcp-forward	TCP-forward trace. Traffic trace with <code>/tcp api-gateway</code> is displayed, e.g., TCP tunneling information when starting a launcher.
both	Internal FortiPAM and TCP-forward trace. HTTP traffic with <code>/tcp</code> and <code>/pam api-gateway</code> is displayed.



For most cases, the `both` option is recommended for the filter.



The FortiPAM filter can be used with `diagnose wad filter drop-unknown-session 1` to ignore more information during session initialization.

- Examples

1. Turning on `drop-unknown-session` with the `internal` option (diagnose wad filter pam internal) and launching a secret shows the following trace:

```
PAM # [I][p:1070][s:930509823][r:2694] wad_http_req_proc_policy: 10453 ses_
    ctx:ct|Pvx|M|H|C|A|l fwd_srv=<nil>[I][p:1070][s:930509823][r:2694] wad_dump_fwd_
    http_resp: 2663 hreq=0x7f34b46a2e58 Forward response from Internal:
HTTP/1.1 200 OK
Content-Type: application/json
Content-Length: 309
[I][p:1070][s:930509826][r:2701] wad_dump_fwd_http_resp: 2663 hreq=0x7f34b46a2e58
    Forward response from Internal:
HTTP/1.1 200 OK
```

```
Proxy-Agent: FortiPAM/1.0
X-Range: bytes=773458-
Content-Length: 0
```

- Turning on drop-unknown-session with the tcp-forward option (diagnose wad filter pam tcp-forward) and launching a secret shows the following trace:

```
[I][p:1070][s:930509852][r:2799] wad_http_req_check_vs_tunnel_type :5182 Check redir
PROXY port=22((null))
[I][p:1070][s:930509852][r:2799] wad_http_req_check_vs_tunnel_type :5190 TCP tunnel
detected without type.
[I][p:1070][s:930509852][r:2799] wad_dump_fwd_http_resp :2663 hreq=0x7f34b46a41f8
Forward response from Internal:
HTTP/1.1 101 Switching Protocols
Upgrade: tcp-forwarding/1.0
Connection: Upgrade
```

Issue: WebRDP session recording fails and closes active session

Applies to web based secret launching failures

To solve WebRDP session recording failure and closure of active session:

- In the CLI console, enter the following commands:

```
diagnose debug enable
diagnose wad debug enable level verbose
diagnose wad debug enable category http
diagnose wad debug enable category pam-video #If session recording is enabled
```

Alternatively, in the FortiPAM GUI:

- Go to *Log & Report > Debug Settings*.
The *Debug Settings* window opens.
- In the *Trace Logs* pane:
 - Enable *Debug*.
 - In *Category*, select +, from the list, select *Http* and *PAM Video*.
 - In the *Debug Level* dropdown, select *Verbose*.
 - Enable *Overwrite*.

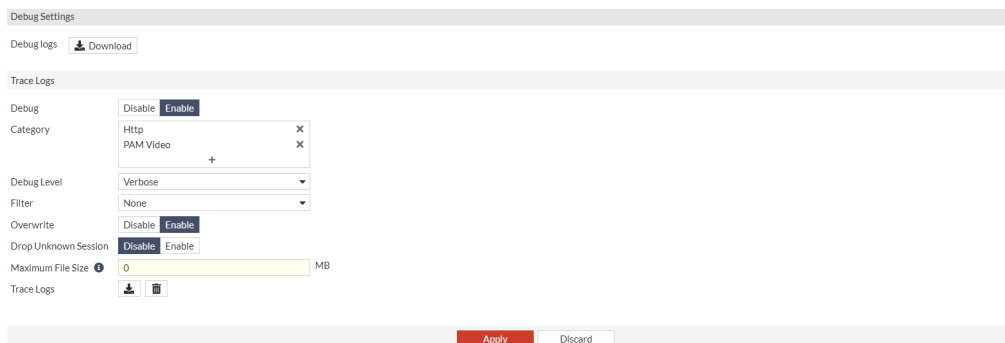

- Click *Apply*.
- Reproduce the issue.
- Return to *Log & Report > Debug Settings*.

- f. In the *Trace Logs* pane, select the download icon (↓) to download the trace log.
A `.tar` trace file is downloaded on your computer.

Troubleshooting log and video disk encryption issues

Issue 1:

How to check disk encryption configuration and disk format?

The command `execute disk encryption status` shows both disk encryption configuration under `config secret` setting and also the format of log and video disks.

For example:

```
execute disk encryption status
In Configuration file, Disk encryption setting is Enable
Log Disk is /dev/sdb1 and it is in encrypted format.
Video Disk is /dev/sdc1 and it is in encrypted format.
```

[Good] Disk format matches the disk encryption setting in configuration file.

If there is problem regarding log or video,
Run command 'execute disk encryption log' for more information.
Run command 'execute disk encryption video' for more information.

Issue 2:

How to check the log or video disk status?

Use `execute disk encryption log` or `execute disk encryption video` command.

Where:

1. **Mount:** Indicates if the directory for log and video is correctly mounted to the disk device. An error usually means the log or video cannot be successfully saved into FortiPAM.
2. **Configuration:** Shows both the disk encryption configuration under `config secret` setting and the format of log and video disk. When configuration and disk format do not match, you need to check whether the correct configuration file is used or format the disk based on the setting in the configuration file.
3. **Open:** Disks can only be opened by using the correct `disk-encryption-password`. When the disk fails to open, it usually means the password in the configuration is incorrect.
4. **LUKS HEADER:** Dumps the encrypted disk header containing the disk label and other information.

For example:

```
execute disk encryption log
```

Log disk status:

1. **Mount:**
 device name: `/dev/mapper/dm_log`
 directory: `/var/log`

filesystem type: ext4

2. Configuration:

In the configuration file, disk encryption is Enable.

Disk is /dev/sdb1 and it is in encrypted format.

[Good] Disk format matches the disk encryption setting in configuration file.

3. Open:

[Good] Disk is opened and active.

4. Disk LUKS HEADER:

LUKS header information

Version: 2

Epoch:3

Metadata area: 16384 [bytes]

Keyslots area: 16744448 [bytes]

UUID: 5633c25c-19e7-42e7-97f6-c62d2829bbba

Label: LOGUSEDX8FAC98BD

Subsystem: (no subsystem)

Flags: (no flags)

Data segments:

0: crypt

offset: 16777216 [bytes]

length: (whole device)

cipher: aes-xts-plain64

sector: 512 [bytes]

Keyslots:

0: luks2

Key: 512 bits

Priority: normal

Cipher: aes-xts-plain64

Cipher key: 512 bits

PBKDF: argon2id

Time cost: 4

Memory: 774464

Threads: 2

Salt: d7 8c 1c f1 6d c0 f1 99 ed 00 3b 48 5f 6a 10 07

b4 17 f0 06 67 1b 51 f0 d9 53 80 df 0d 39 ff 74

AF stripes: 4000

AF hash: sha256

Area offset:32768 [bytes]

Area length:258048 [bytes]

Digest ID: 0

Tokens:

Digests:

0: pbkdf2

Hash: sha256

Iterations: 81715

Salt: 56 69 3c d0 f3 77 04 e5 e7 ec 2b 71 dd 66 28 33

0e 5c 07 8b 43 0c 27 47 48 ab 29 ee 95 ab 5d 58

Digest: 5e 8a dc b8

Issue 3:

What to do when there is `Open disk failed!` message after FortiPAM starts?

When there is `Open disk failed!` message when FortiPAM starts such as following:

```
System is starting...
we have 2 interfaces
Open disk failed! dev=/dev/vda1
Open dev /dev/vda1 in encryption format failed. ret=-4
```

Use `execute disk encryption` to get more help message.

```
execute disk encryption
```

`enable`: enable disk encryption on log and video disk.

`disable`: disable disk encryption on log and video disk.

`log`: check log disk encryption status.

`status`: check disk encryption status.

`video`: check video disk encryption status

Issue 4:

What to do when configuration does not match the disk format?

When disk-encryption setting in the configuration file and disk format does not match, use commands `execute disk encryption status` to get more help message.

```
FPAVUL2022103101 login:Disk Encryption is disabled in configuration file, but disk is in
encrypted format! Device: /dev/vdb1
Run command 'execute disk encryption stat[ 35.678543] EXT4-fs (vdb1): VFS: Can't find
ext4 filesystem us' for more information.
Storage HD2 mount failed. Giving up.
FPAVUL2022103101 login: admin
```

```
Password:
Welcome!
FPAVUL2022103101 # execute disk encryption status
In the configuration file, disk encryption setting is Disable
Log Disk is /dev/vda1 and it is in encrypted format.
Video Disk is /dev/vdb1 and it is in encrypted format.
[Error] Disk format does not match the disk encryption setting in configuration file.
```

Option 1:

Restore a previous backup configuration that contain `set disk-encryption enable` under `config secret` setting.

Contents in the disks could be kept if correct configuration is restored.

Option 2:

To enable disk encryption, run `execute disk encryption enable` command.

Option 3:

Run `execute disk format` command to format disk based on disk encryption setting.

Note that for option 2 and 3, disk will be encrypted/ formatted and all the content on the log and video disk is lost.

FortiClient troubleshooting tips

After you configure the required secrets, FortiClient uses the following three processes to launch the native application and start the video recording services:

- FortiVRS with session ID: 0
 - Save and drop ZTNA rules for each secret request.
 - Manage FortiVRS[X] daemons.
 - Upload video and metadata files to FortiPAM.
- FortiVRS with the user session
 - Start applications in the user session.
 - Record application videos.
 - Record the key and mouse metadata for the launched secret.
- FortiTCS
 - ZTNA daemon feature (responsible for TCP forwarding).
 - Create local proxy to forward TCP traffic.

Issue 1: Error contacting FortiClient

Ensure that FortiClient is running with the following three daemons:

- FortiTCS in session 0
- FortiVRS in session 0
- FortiVRS in user session [X]

Issue 2: Error starting the program

Ensure that the secret you are launching is installed on the client side machine with the environment variable set.

Issue 3: FortiPAM JSON error

This happens if you tamper the `ztna.config` file.

To recover, delete `ztna.config` and try again.

Issue 4: HTTP port mismatch between FortiPAM and FortiClient

Both FortiPAM and FortiVRS must use the same HTTP port.

To check for the port mismatch:

1. On FortiPAM, look for the value set in the *Client Port* field in the *Advanced* tab in *System > Settings*.
2. On the client machine, in the `fortivrs_session_0_1.log` file, ensure that the listening port is same as the *Client Port* on FortiPAM.
3. If there is a mismatch between the port value in step 1 and 2, change the port value on FortiPAM to match the client machine port.

Issue 5: Secret not reaching the host

FortiClient can no longer reach the EMS server. Although ZTNA tunnels/rules can still be created, they fail to reach the host without an EMS connection.

Check the EMS server connection.



For fortitcs/fortivrs traces, go to `logs\trace\` in the FortiClient installation directory.



For the ZTNA configuration file, go to `C:\Users\Public\FortiClient\ztna\`.



For the secret session video recordings and metadata files, go to the Windows Temp directory `C:\Windows\Temp`.

Hardening

System hardening reduces security risk by eliminating potential attack vectors and shrinking the system's attack surface.

This chapter describes some best practices that contribute to the hardening of the FortiPAM device.

The following topics are included in this section:

- [Secure password storage on page 394](#)
- [Verify the private-data-encryption feature Example on page 395](#)
- [How to restore a backup configuration file with private-data-encryption enabled Example on page 395](#)
- [Enabling private-data-encryption on an HA cluster Example on page 396](#)

Secure password storage

The passwords, and private keys used in certificates, that are stored on the FortiPAM are encrypted using a predefined private key, and encoded when displayed in the CLI and configuration file.

Passwords cannot be decrypted without the private key and are not shown anywhere in clear text. The private key is required on other FortiPAM to restore the system from a configuration file. In an HA cluster, the same key should be used on all of the units.

To enhance password security, specify a custom private key for the encryption process. This ensures that the key is only known by you.

FortiPAM models with a Trusted Platform Module (TPM) can store the primary encryption password, which is used to generate the primary encryption key, on the TPM. For more information, see [FortiPAM with TPM on page 38](#).

To configure the private encryption key:

1. In the CLI console, enter the following commands:

```
config system global
  set private-data-encryption enable
end
Please type your private data encryption key (32 hexadecimal numbers):
*****
Please re-enter your private data encryption key (32 hexadecimal numbers) again:
*****
Your private data encryption key is accepted.
```

See [Verify the private-data-encryption feature Example on page 395](#).

Verify the private-data-encryption feature - Example

In this topic, we demonstrate how to verify the `private-data-encryption` feature, also known as Secure password storage. See [Secure password storage on page 394](#).

To verify the private-data-encryption feature:

1. After configuring the custom 32 characters hexadecimal private data encryption key as shown in [Secure password storage on page 394](#), in the CLI console, enter the following commands and note down the `B64TEXT` and `B64HMAC` sample keys that appear:

```
execute private-encryption-key sample
```

The following shows an example of successful activation:

```
execute private-encryption-key sample
B64TEXT: oR3J+DhKPF4xSFDZv43o/pkRBCTop+4w1IU80EaLh5I=
B64HMAC: /4e77yCRzi6hunROBdm+/97bthc=
```

The following shows an example where the `private-data-encryption` feature is not enabled:

```
execute private-encryption-key sample
Private encryption is not enabled.
Command fail. Return code 7.
```

2. In the CLI console, enter the following commands to verify the `private-data-encryption` feature:

```
execute private-encryption-key verify <B64TEXT> <B64HMAC>
execute private-encryption-key verify oR3J+DhKPF4xSFDZv43o/pkRBCTop+4w1IU80EaLh5I=
/4e77yCRzi6hunROBdm+/97bthc=
Verification passed.
```

Or

```
get system status | grep "Private Encryption"
Private Encryption: Enable
```

How to restore a backup configuration file with private-data-encryption enabled - Example

In this topic, we demonstrate how to restore a backup configuration file with `private-data-encryption` enabled when the FortiPAM device is factory reset or replaced due to hardware failure.

Here, `private-data-encryption` is enabled with `0123456789abcdef0123456789abcdef` as the private key.

To restore a backup configuration file:

1. In the CLI console, enter the following commands to enable `private-data-encryption`:

```
config system global
set private-data-encryption enable
```

```
end
Please type your private data encryption key (32 hexadecimal numbers):
0123456789abcdef0123456789abcdef
Please re-enter your private data encryption key (32 hexadecimal numbers) again:
0123456789abcdef0123456789abcdef
Private data encryption key is accepted.
```

2. To back up and restore configuration files, see [Backup and restore](#).
-



In case the FortiPAM device accidentally factory resets or there is a hardware failure, restoring the backed up configuration file does not retrieve all the previously encrypted passwords.

The following shows the configuration file error when booting up:

```
Initializing firewall...
System is starting...
The config file may contain errors,
Please see details by the command 'diagnose debug config-error-log
read'
```

3. To restore the configuration on factory reset or on a new FortiPAM device, you must set the private key prior to restoring the configuration file:

```
config system global
  set private-data-encryption enable
end
Please type your private data encryption key (32 hexadecimal numbers):
0123456789abcdef0123456789abcdef
Please re-enter your private data encryption key (32 hexadecimal numbers) again:
0123456789abcdef0123456789abcdef
```

4. The private data encryption key is accepted.
When this private data encryption key is entered, the configuration file is restored.

Enabling private-data-encryption on an HA cluster - Example

When using an HA cluster, the keys used for `private-data-encryption` are synchronized among all the cluster members.



In a redundant setup (HA), the units must have the same key so that the encrypted elements are properly synchronized.

To enable private-data-encryption before the HA cluster is formed:

1. In the CLI console, on each member of the HA cluster to be formed, enter the following commands:

```
config system global
  set private-data-encryption enable
end
Please type the private data encryption key (32 hexadecimal numbers):
0123456789abcdef0123456789abcdef
```

```
Please re-enter the private data encryption key (32 hexadecimal numbers) again:
0123456789abcdef0123456789abcdef
The private data encryption key is accepted.
```

To enable private-data-encryption on the HA cluster:

1. In the CLI console, on any member of the HA cluster, enter the following commands:

```
config system global
  set private-data-encryption enable
end
Please type the private data encryption key (32 hexadecimal numbers):
0123456789abcdef0123456789abcdef
Please re-enter the private data encryption key (32 hexadecimal numbers) again:
0123456789abcdef0123456789abcdef
The private data encryption key is accepted.
```

The setting and the key is pushed to all the members in the HA cluster.

Appendix A: Installation on KVM

Once you have downloaded the `fortipam.qcow2` you can create the virtual machine in your KVM account.

To deploy FortiPAM virtual machine:

1. Launch *Virtual Machine Manager* on your KVM host server.
2. From the Virtual Machine Manager (VMM) home page, select *Create a new virtual machine*.
3. Select *Import existing disk image* and select *Forward*.
4. Select *Browse*.
If you saved the `fortipam.qcow2` file to `/var/lib/libvirt/images`, it will be visible on the right. If you saved it somewhere else on your server, select *Browse Local*, find it, and select *Open*.
5. Select the *OS type* as *Generic default* and select *Forward*.
6. Specify the amount of memory and the number of CPUs to allocate to this virtual machine.
You can set the memory as 4GB and the CPUs to 4.
Select *Forward*.
7. Enter the name for the VM.
A new VM includes one network adapter by default.
8. Check *Customize configuration* before installation, and select *Finish*.

To add additional hard disks:

Before opening your virtual machine for the first time you will need to configure two additional hard disks.

1. Click *Add Hardware* in the Virt-manager application, and select the option to add an additional storage disk.
2. For the *Storage size*, select a size according to the disk sizing guidelines. See *System requirements* in the [KVM Admin Guide](#).
3. For *Bus type* select *VirtIO*.
4. Click *Finish*.

To add ethernet interfaces:

Before opening your virtual machine for the first time you will need to configure two ethernet interfaces.

1. In the Virtual Machine Manager, locate the VM name, then select *Open* from the toolbar.
2. Select `NIC: xxxx`; the default network adapter.
3. In *Network source* dropdown, select `Host device enxxxx: macvtap`.
4. In the *Device model* dropdown, select *virtio*.
5. Click *Apply*.
6. Click *Add Hardware*, and select the option to add an additional interface.
7. In the *Device model* dropdown, select *virtio*.
8. Select *Finish*.
9. Click *Begin Installation* to start installing the new VM.

To add log/video disks or modify disk sizes after first powering up FortiPAM-VM:

1. In the CLI console, enter `sh sys storage` to verify that the disk size change was successful:

```
config system storage
  edit "HD1"
    set status enable
    set media-status enable
    set order 1
    set partition "LOGUSEDX83555B0F"
    set device "/dev/vda1"
    set size 20029
    set usage log
  next
  edit "HD2"
    set status enable
    set media-status enable
    set order 2
    set partition "PAMVIDEOBAED79CD"
    set device "/dev/vdb1"
    set size 301354
    set usage video
  next
  edit "HD3"
    set status enable
    set media-status disable
    set order 3
    set partition ''
    set device ''
```

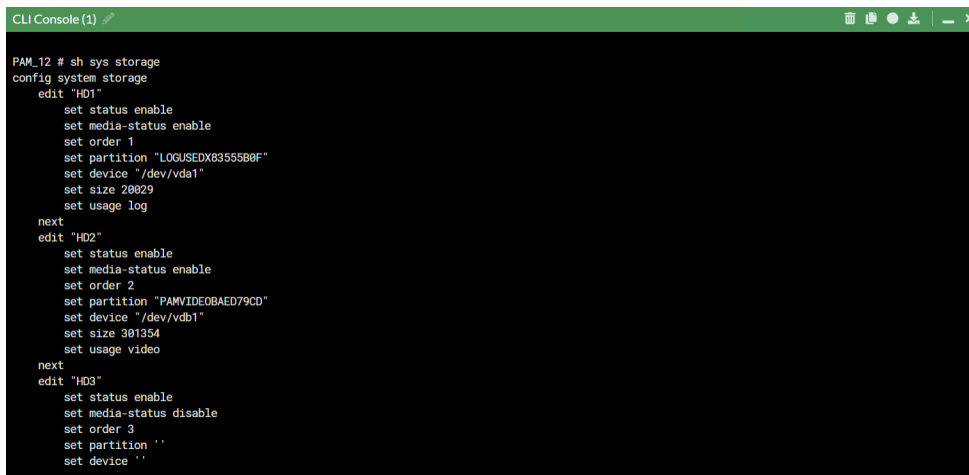

```
CLI Console (1)
PAM_12 # sh sys storage
config system storage
  edit "HD1"
    set status enable
    set media-status enable
    set order 1
    set partition "LOGUSEDX83555B0F"
    set device "/dev/vda1"
    set size 20029
    set usage log
  next
  edit "HD2"
    set status enable
    set media-status enable
    set order 2
    set partition "PAMVIDEOBAED79CD"
    set device "/dev/vdb1"
    set size 301354
    set usage video
  next
  edit "HD3"
    set status enable
    set media-status disable
    set order 3
    set partition ''
    set device ''
```

If the displayed disk size is not what you had configured, enter the following command to format the log and the video disk:

```
execute disk format <disk_ref>
```

Note: <disk_ref> can be checked using the command `execute disk list`.



```
CLI Console (1)
PAM_12 # exec disk list
Disk HD1          ref: 256 20.061B   type: IDE [] dev: /dev/vda
  partition ref: 257 19.661B, 19.461B free mounted: Y label: LOGUSEDX83555B0F dev: /dev/vda1 start: 2048
Disk HD2          ref: 16 300.061B  type: IDE [] dev: /dev/vdb
  partition ref: 17 294.361B, 293.261B free mounted: Y label: PAMVIDEOBAED79CD dev: /dev/vdb1 start: 2048
PAM_12 #
```

HD1 is used for the log disk and the `disk_ref` is 256.

HD2 is used for the video disk and the `disk_ref` is 16.

In the above example, disks can be formatted by entering the following commands:

```
execute disk format 256 #HD1
execute disk format 16 #HD2
```



Disk formatting results in the loss of all existing logs and videos.

Appendix B: Installation on VMware

Once you have downloaded the `out.ovf.zip` file and extracted the package contents to a folder on your management computer, you can deploy it into your VMware environment.

To deploy the FortiPAM-VM OVF template:

1. Connect to your VMware ESXi server by visiting its URL in your browser. Enter your username and password, and click *Log in*.
2. Select *Create/Register VM*.
The VM creation wizard opens.
3. Select *Deploy a virtual machine from an OVF or OVA file*, and click *Next*.

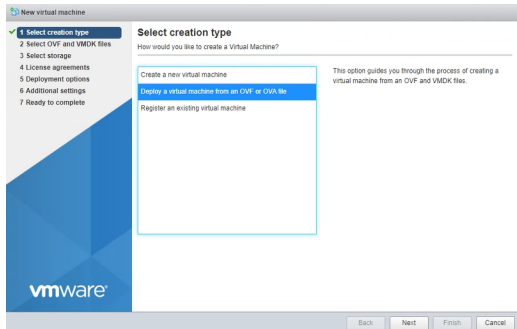

4. Enter a name for your VM and select the files (FortiPAM-VM64.ovf, fortipam.vmdk, datadrive.vmdk, and datadriv2.vmdk) previously extracted to your management computer, and click *Next*.

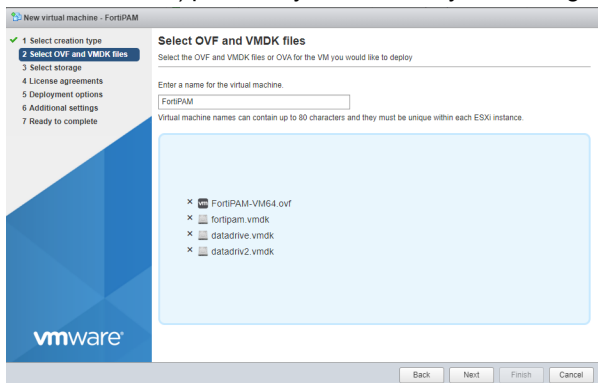

5. Select which ESXi server's datastore to use for the deployment of FortiPAM-VM, and click *Next*.

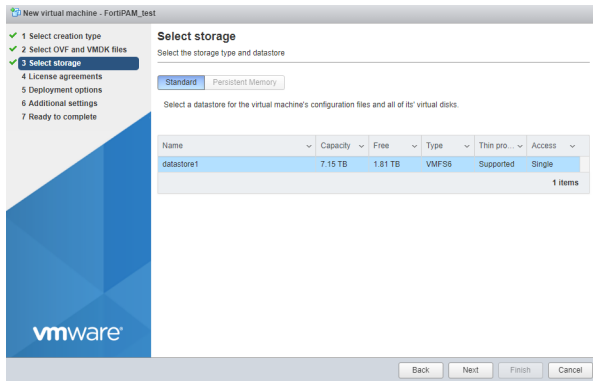

6. Read the licensing terms and click *I agree* and *Next*.

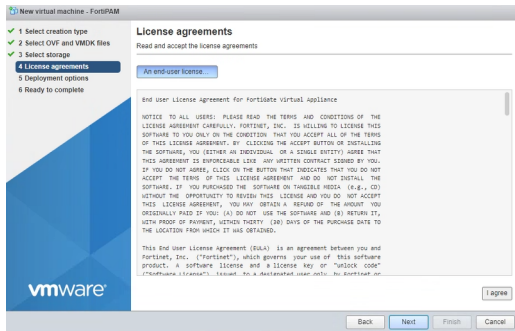

7. Select the appropriate network mappings, disk provisioning, and power on options for your deployment, and click *Next*.

- **Thin Provision:** This option optimizes storage use at the cost of sub-optimal disk I/O rates. It allocates disk space only when a write occurs to a block, but the total volume size is reported by VMFS to the OS. Other volumes can take the remaining space. This allows you to float between your servers and expand storage when your size monitoring indicates there is a problem. Once a Thin Provisioned block is allocated, it remains in the volume regardless of whether you have deleted data, etc.
- **Thick Provision:** This option has higher storage requirements, but benefits from optimal disk I/O rates. It allocates the disk space statically. No other volumes can take the allocated space.

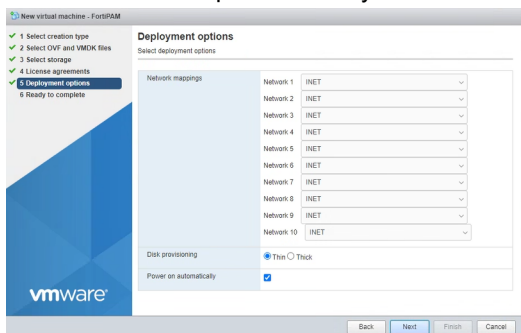

By default, the log disk and video disk size are 30 GB. If you want to change the size, unselect *Power on automatically* to ensure that any disk size change is made before first powering on the VM.

- e. Adjust *Hard disk 2* for log disk size and adjust *Hard disk 3* for video disk size.

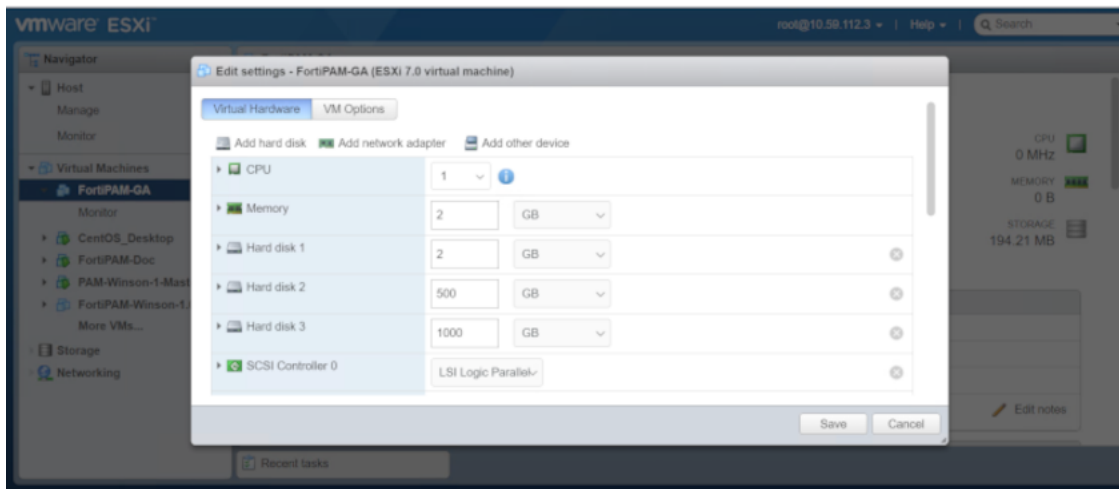

- f. Click **Save** to save the changes.
You can now power on the VM.

11. If *Power on automatically* is unselected in step 7 and the VM has never been powered on, any disk size change automatically takes effect after the VM is powered on the first time.
If the disk sizes are tuned after powering on the VM for the first time, enter `sh sys storage` CLI command to verify that the disk size change was successful:

```
config system storage
edit "HD1"
    set status enable
    set media-status enable
    set order 1
    set partition "LOGUSEDX83555B0F"
    set device "/dev/vda1"
    set size 20029
    set usage log
next
edit "HD2"
    set status enable
    set media-status enable
    set order 2
    set partition "PAMVIDEOBAED79CD"
    set device "/dev/vdb1"
    set size 301354
    set usage video
next
edit "HD3"
    set status enable
    set media-status disable
    set order 3
    set partition ''
    set device ''
```

```

CLI Console (1)
PAM_12 # sh sys storage
config system storage
edit "HD1"
set status enable
set media-status enable
set order 1
set partition "LOGUSEDX83555B8F"
set device "/dev/vda1"
set size 20029
set usage log
next
edit "HD2"
set status enable
set media-status enable
set order 2
set partition "PAMVIDEOBAED79CD"
set device "/dev/vdb1"
set size 301354
set usage video
next
edit "HD3"
set status enable
set media-status disable
set order 3
set partition ""
set device ""

```

If the displayed disk size is not what you had configured, enter the following command to format the log and the video disk:

```
execute disk format <disk_ref>
```

Note: <disk_ref> can be checked using the command `execute disk list`.

```

CLI Console (1)
PAM_12 # exec disk list
Disk HD1      ref: 256 20.06iB  type: IDE [] dev: /dev/vda
partition ref: 257 19.66iB, 19.46iB free mounted: Y label: LOGUSEDX83555B8F dev: /dev/vda1 start: 2048
Disk HD2      ref: 16 300.06iB  type: IDE [] dev: /dev/vdb
partition ref: 17 294.36iB, 293.26iB free mounted: Y label: PAMVIDEOBAED79CD dev: /dev/vdb1 start: 2048
PAM_12 #

```

HD1 is used for the log disk and the `disk_ref` is 256.

HD2 is used for the video disk and the `disk_ref` is 16.

In the above example, disks can be formatted by entering the following commands:

```
execute disk format 256 #HD1
execute disk format 16 #HD2
```



Disk formatting results in the loss of all existing logs and videos.

Appendix C: Installing vTPM package on KVM and adding vTPM to FortiPAM-VM

For added security when installing FortiPAM on KVM, vTPM package must be installed, and vTPM added to the FortiPAM-VM.

To install vTPM package on KVM (Ubuntu):

1. In the command line, enter the following commands:

```
mkdir TPM_WorkSpace
cd TPM_WorkSpace/
git clone https://git.seabios.org/seabios.git
git clone https://github.com/stefanberger/libtpms.git
ls
cd libtpms
sudo apt-get -y install automake autoconf libtool gcc build-essential libssl-dev dh-
    exec pkg-config gawk
./autogen.sh --with-openssl --with-tpm2
make dist
dpkg-buildpackage -us -uc -j$(nproc)
cd ..
ls
sudo dpkg -i libtpms0_0.10.0~dev1_amd64.deb libtpms-dev_0.10.0~dev1_amd64.deb
git clone https://github.com/stefanberger/swtpm.git
cd swtpm
sudo su
ln -s /dev/null /etc/systemd/system/trousers.service
exit
sudo apt-get -y install libfuse-dev libglib2.0-dev libgmp-dev expect libtasn1-dev
    socat tpm-tools python3-twisted gnutls-dev gnutls-bin softhsm2 libseccomp-dev
    dh-apparmor libjson-glib-dev
dpkg-buildpackage -us -uc -j$(nproc)
dpkg -i swtpm_0.8.0~dev1_amd64.deb swtpm-dev_0.8.0~dev1_amd64.deb swtpm-libs_
    0.8.0~dev1_amd64.deb swtpm-tools_0.8.0~dev1_amd64.deb
```

To add vTPM when creating a FortiPAM-VM:

1. Deploy FortiPAM, see [Appendix A: Installation on KVM on page 398](#).
2. Before opening the virtual machine for the first time, in the Virt-manager application, click *Add Hardware*.
3. From the menu, select *TPM*.
4. In the *Details* tab:
 - a. In *Model*, select *CRB*.
 - b. In *Backend*, select *Emulated device*.
 - c. In *Version*, select *2.0*.

d. Click *Finish*.

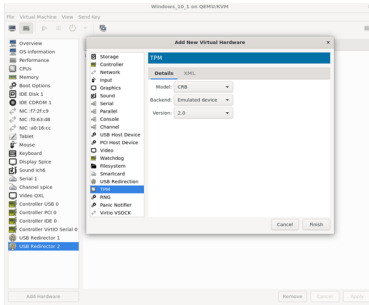

This adds *TPM v2.0* to the list of hardware devices on the left.

Appendix D: vTPM for FortiPAM on VMware

To successfully enable vTPM, you must configure a key provider on the VMware vSphere client.



Ensure that TPM is set up as part of the initial configuration, i.e., before powering on the FortiPAM-VM for the first time.

To configure a key provider:

1. Select the virtual appliance in the VMware vSphere client and go to *Configure > Security > Key Providers*.
2. In *Key Providers*, from the *Add* dropdown, select *Add Native Key Provider*.
3. In the *Add Native Key Provider* window:
 - a. Enter a name for the native key provider.
 - b. Deselect *Use key provider only with TPM protected ESXi hosts*.
 - c. Select *ADD KEY PROVIDER*.
4. Select the new key provider from the key providers list and then select *BACK UP*.
The *Back up Native Key Provider* window opens.
5. Select *BACK UP KEY PROVIDER*.
The key provider is saved on your computer.

To enable vTPM for FortiPAM:

1. Right-click the virtual appliance in the VMware vSphere client and select *Edit Settings*.



Ensure that the *Guest OS Version* in *VM Options* tab is set to *Other 4.x or later Linux (64-bit)* or higher.

2. In *Edit Settings*, click *Add New Device* and select *Trusted Platform Module*.
3. Click *OK*.

Appendix E: Enabling soft RAID on KVM or VMware

To expand hard disk capacity, you can enable RAID on the FortiPAM-VM. After RAID is enabled, hard disk capacity can be expanded from 2 TB to 16 TB.

Individual disks of sizes up to 2 TB are supported.



Starting FortiPAM 1.1.0, the disk size is limited by the GPT partition size.

Soft RAID is supported on KVM and VMware platforms. Hyper-V and other platforms are not supported yet.

Note: Soft RAID for VMware requires disks of the same size.



RAID can only be configured using the CLI commands.



Enabling, disabling, and changing the RAID level, erases all the data on the log and video disk. Also, the FortiPAM device reboots every time RAID is enabled, disabled, or the RAID level is changed.

To configure RAID via CLI:

1. Before enabling RAID, enter the following command in the CLI console to verify that the FortiPAM has multiple disks:

```
execute disk list
```

or

```
diagnose hardware deviceinfo disk
```



Use `diagnose system disk info` to check the disk-related information.

2. In the CLI console, enter the following command to enable RAID:

```
execute disk raid enable <RAID level> #The default value is Raid-0
```

Two partitions will be created after RAID is enabled. One partition for log and one for video.



To disable RAID, enter `execute disk raid disable`.



When there are two disks, RAID level 0 and 1 are available. Only when there are four disks, RAID level 5 and 10 are available.

3. From the *Admin* dropdown in the banner, go to *System > Reboot* to reboot FortiPAM.
-



Reboot is only available when FortiPAM is in maintenance mode.
To enable the maintenance mode, see [Enabling maintenance mode](#).

4. In the *Reboot* window, click *OK* to confirm.
Optionally, enter an event log message.
 5. For the FortiPAM-VM, in the CLI console, check the RAID status by entering the following command:

```
execute disk raid status #Raid is now available
```
-



If the above steps do not enable RAID on FortiPAM-VM, use the following workaround:

1. Factory reset your FortiPAM-VM.
2. Remove disk from your FortiPAM-VM, then add the disk again.
3. Now follow the steps in [Configuring RAID via CLI](#).

Rebuilding a RAID with a different RAID level

Admin can only rebuild RAID at the same RAID level if a RAID error has been detected. Also, changing the RAID level takes a while and deletes all data on the disk.

Use the following CLI command to rebuild RAID:

```
execute disk raid rebuild-level <RAID level>
```

Appendix F: Installation on Hyper-V

Once you have downloaded the `out.hyperv.zip` file and extracted the package contents to a folder on your management computer/Microsoft server, you can deploy the VHD package to your MS Hyper-V environment.

To deploy FortiPAM-VM on MS Hyper-V without TPM support:

1. Launch the Hyper-V Manager on your management computer.
The *Hyper-V Manager* homepage opens.

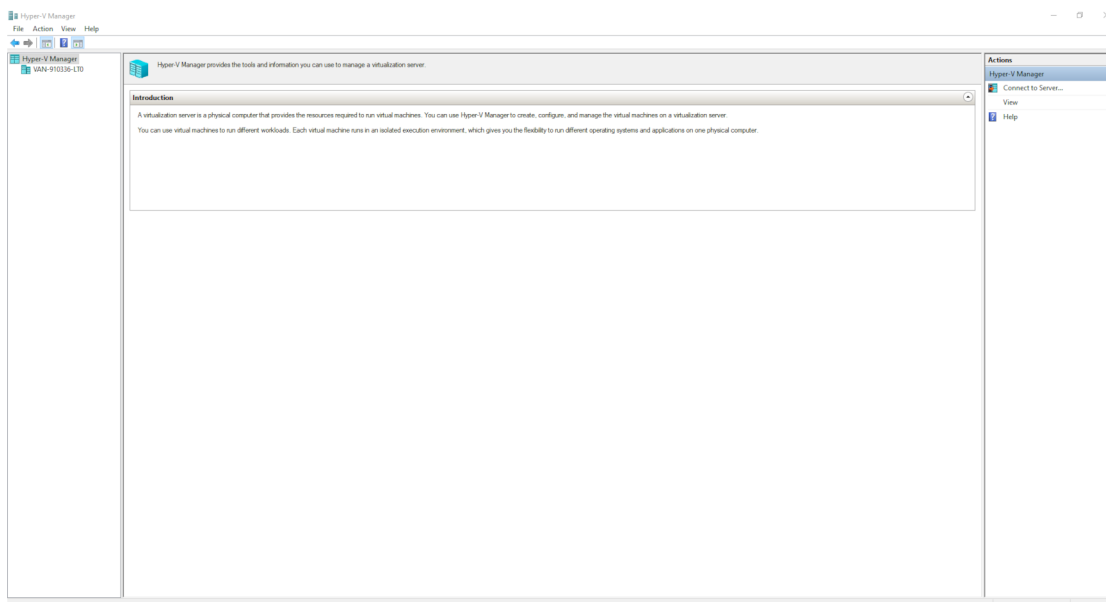

2. In the left tree menu, select your management computer.
The server details page is displayed.

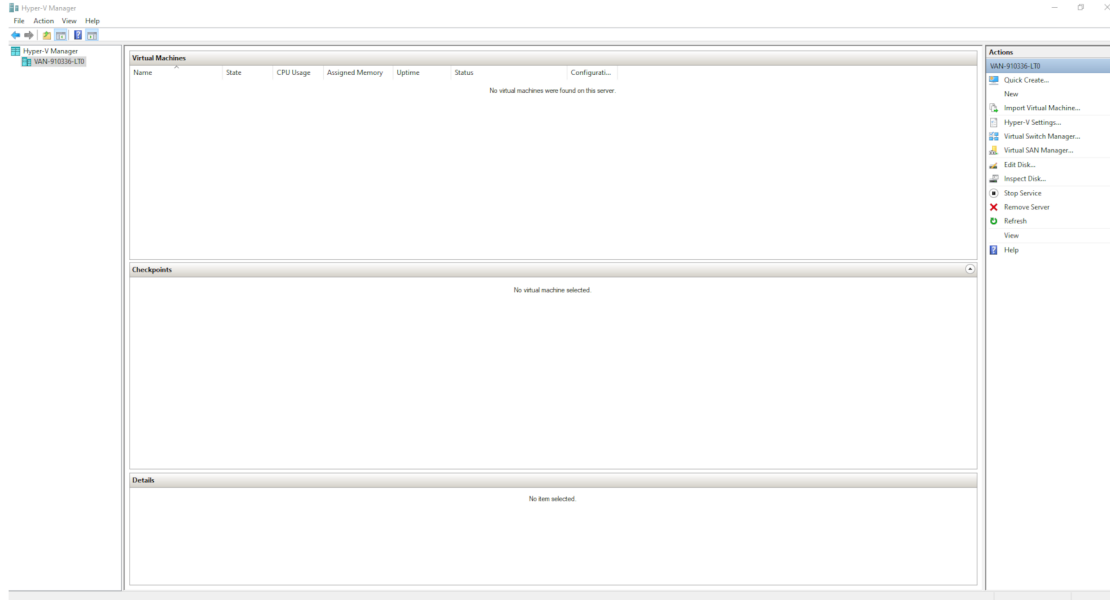

3. Right-click the server/management computer and select *New > Virtual Machine*. Optionally, in the *Action* menu, select *New* and select *Virtual Machine*.

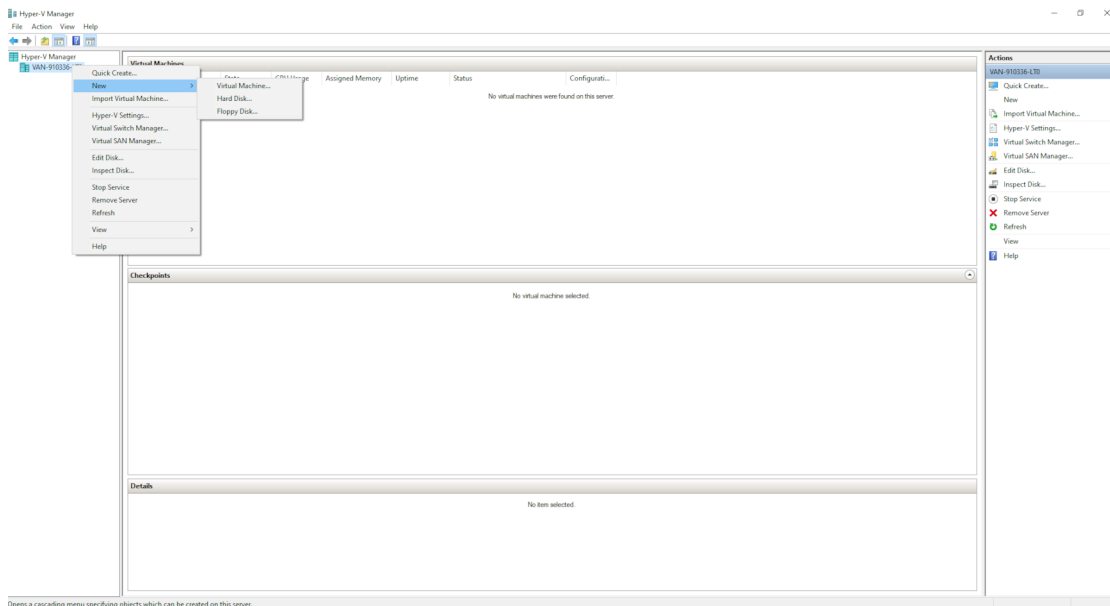

The *New Virtual Machine Wizard* opens.

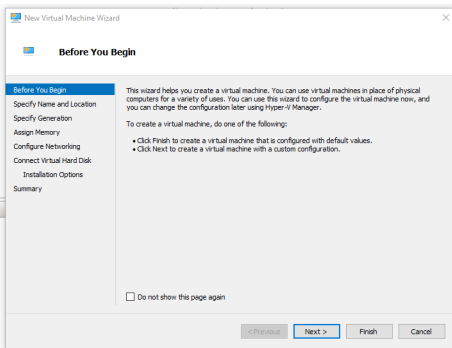

4. In *New Virtual Machine Wizard*, click *Next* to create a VM with a custom configuration. The *Specify Name and Location* tab is displayed.
5. In *Specify Name and Location*, enter a name for this VM, and click *Next*. The *Hyper-V Manager* displays the name you enter for the VM.

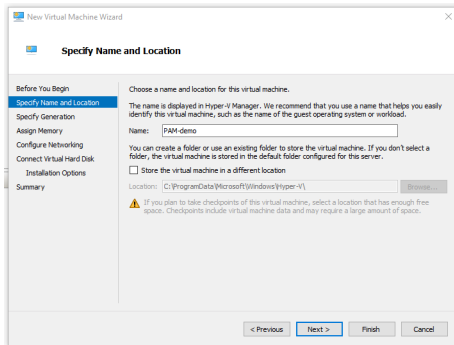

6. In *Specify Generation*, select *Generation 1*, and click *Next*.

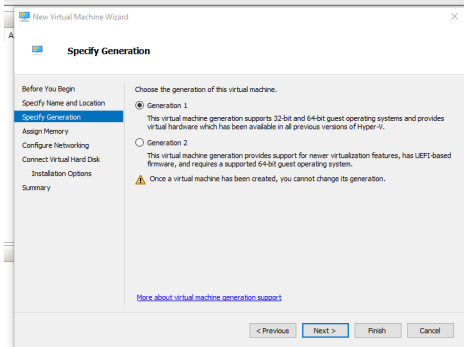

Generation 1 does not support TPM. To install FortiPAM-VM on Hyper-V with TPM, see [Deploying FortiPAM on Hyper-V with TPM](#).

7. In *Assign Memory*, specify the amount of memory to allocate to this VM in *Startup memory*, and click *Next*. Ensure that *Use Dynamic Memory for this virtual machine* is unchecked.

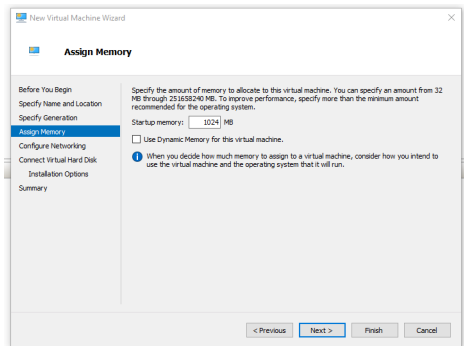

FortiPAM configured with less than 2 CPUs and 2048 MB of RAM works in the evaluation mode until licensed. Otherwise, a valid license is required.

- In *Configure Networking*, from the *Connection* dropdown, select a network adapter, and click *Next*. Each new VM includes a network adapter. You can configure the network adapter to use a virtual switch, or it can remain disconnected. You can configure more network adapters in the *Settings* window later.

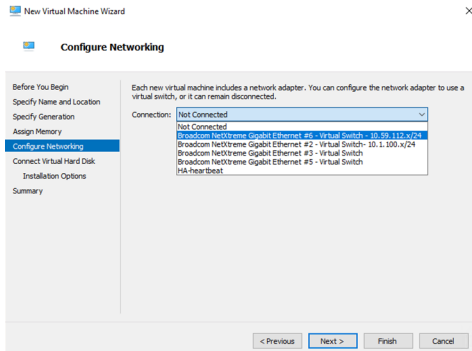

- In *Connect Virtual Hard Disk*, select *Use an existing virtual hard disk*, click *Browse* and locate the `fortipam.vhd` file that you downloaded from [FortiCloud](#), and click *Next*.

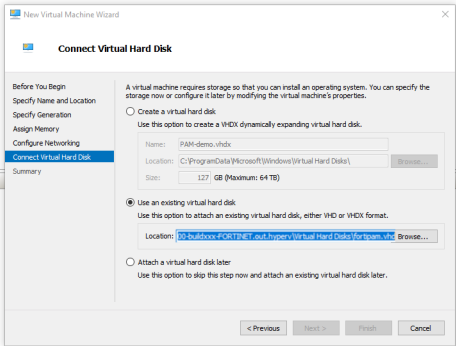

- In *Completing the New Virtual Machine Wizard*, the installation summary is displayed.

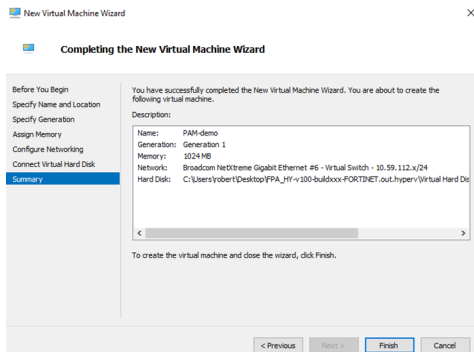

- To create the VM and close the wizard, click *Finish*.
- Right-click the VM and select *Settings* from the menu. Optionally, having selected the VM, in the *Action* menu, click *Settings*.

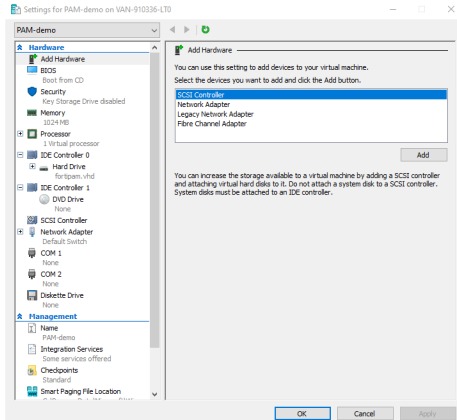

13. In *Hardware*, to remove a DVD drive:
 - a. Select a DVD drive in *IDE Controller 1*.
 - b. Click *Remove*.
 - c. Click *Apply*.

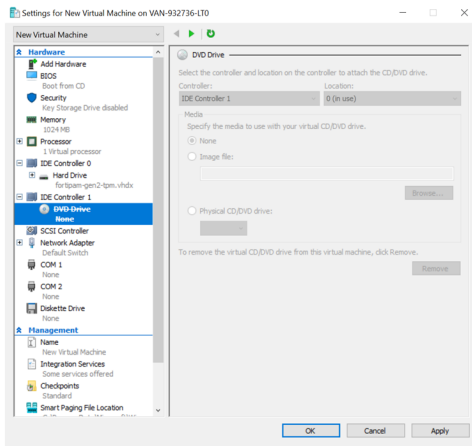

14. In *Hardware*, to add a hard drive:
 - a. Click *IDE Controller 1*.
 - b. Select *Hard Drive*.

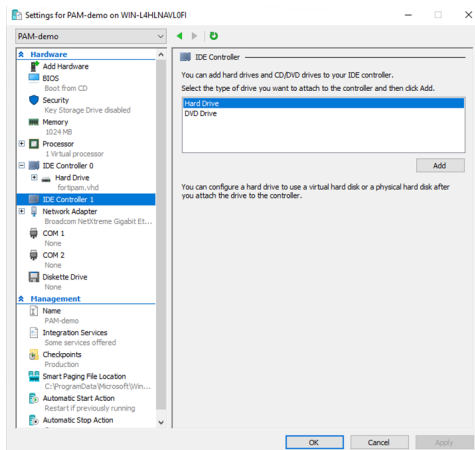

- c. Click *Add*.

- d. In *Hard Drive*, click *Browse* and locate the `DATADRIVE1.vhd` file that is in the same folder as `fortipam.vhd` file.
- e. Click *Apply*.

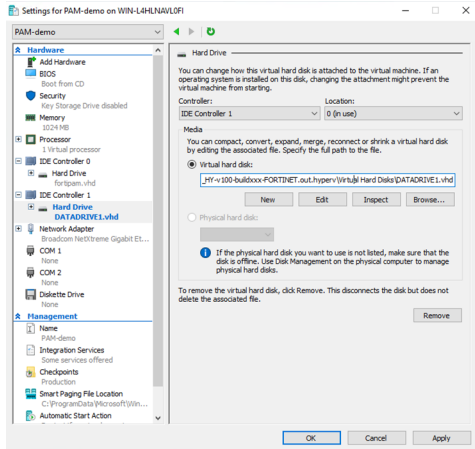

- f. Click *OK*.

- 15. Repeat step 14 to add a second disk, `DATADRIVE2.vhd`.
- 16. From the virtual machines list, right-click the FortiPAM-VM and select *Start* to power on the VM.
- 17. Select your newly created VM and launch it.
See [FortiPAM appliance setup on page 36](#) for CLI related settings to verify the disk usage type and set up FortiPAM.

To deploy FortiPAM-VM on MS Hyper-V with TPM support:

To use FortiPAM with TPM on a Hyper-V platform, first, you must convert the virtual hard disk from `*.vhd` to `*.vhdx` format (step 1) and then specify *Generation 2* when creating a new VM (step 2). Finally, you must enable TPM on Hyper-V before powering on the VM (step 3).

1. Converting hard disk to `*.vhdx`:

- a. In the left tree menu, right-click the server/management computer and select *Edit Disk*. Optionally, having selected the server, select *Action* and then select *Edit Disk*.

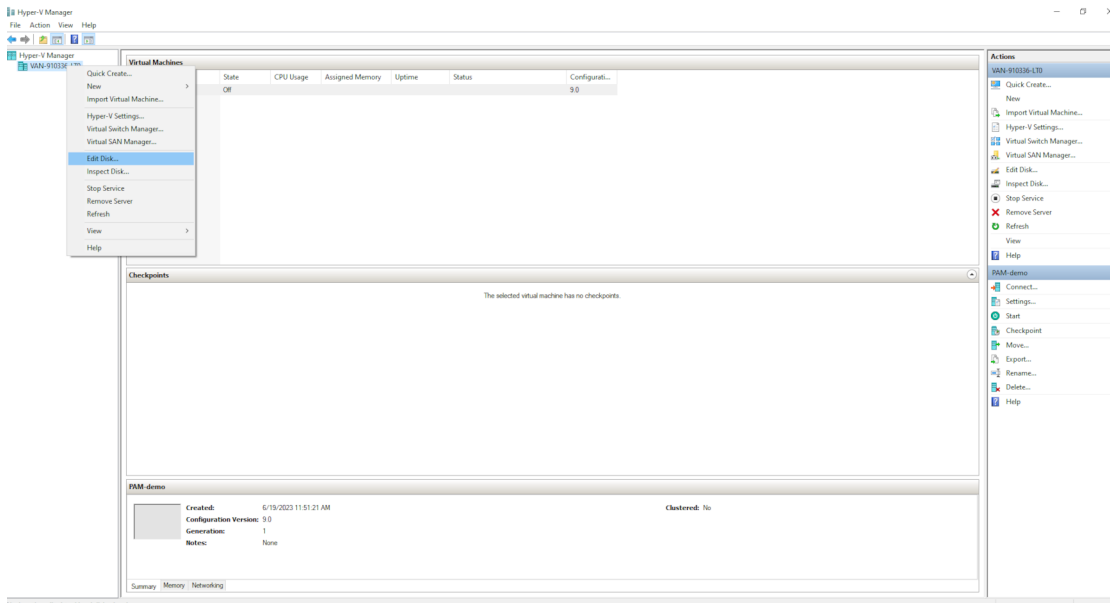

The *Edit Virtual Hard Disk Wizard* opens.

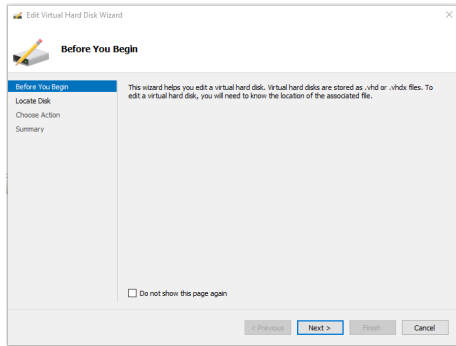

- b. In the *Edit Virtual Hard Disk Wizard*, click *Next*.
- c. In *Locate Virtual Hard Disk*, click *Browse* and locate the `fortipam.vhd` file that you downloaded from FortiCloud, and click *Next*.

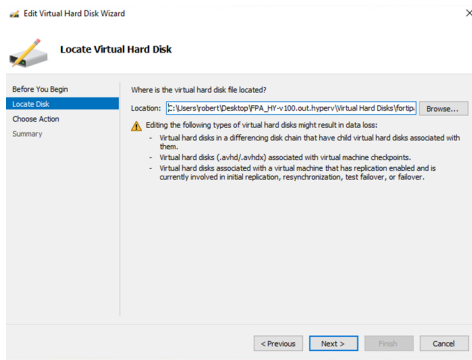

- d. In *Choose Action*, select *Convert*, and click *Next*.

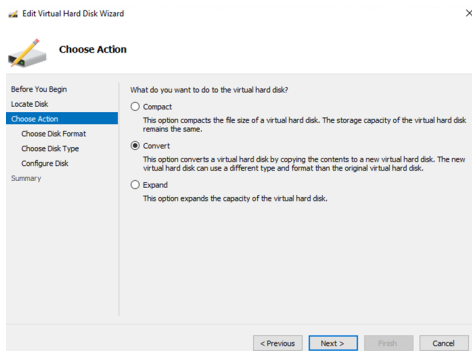

- e. In *Choose Action > Choose Disk Format*, select *VHDX*, and click *Next*.

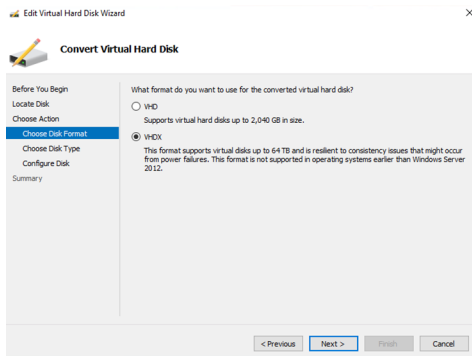

- f. In *Choose Action > Choose Disk Type*, select *Dynamically expanding*, and click *Next*.

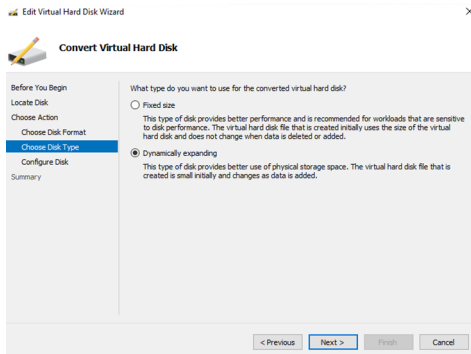

- g. In *Choose Action > Configure Disk*, enter a name for the VHDX disk, click *Browse* to configure a location for this disk, and click *Next*.

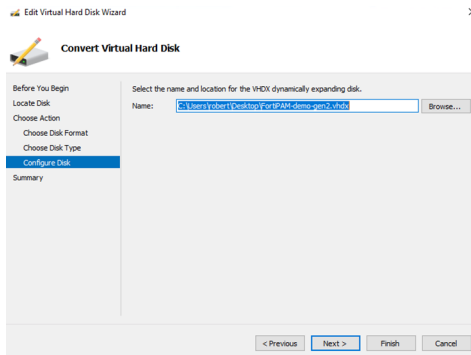

- h. In *Completing the Edit Virtual Hard Disk Wizard*, the summary is displayed.

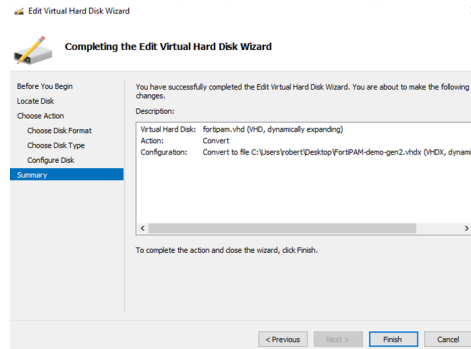

- i. Click *Finish*.
 j. Repeat steps a to i to convert `DATADRIVE1.vhdx` and `DATADRIVE2.vhdx`.

2. Creating a 2nd generation Hyper-V VM:

Follow the same procedure as detailed in [Deploying FortiPAM-VM on Hyper-V without TPM](#), except:

a. In Step 6, select *Generation 2*.

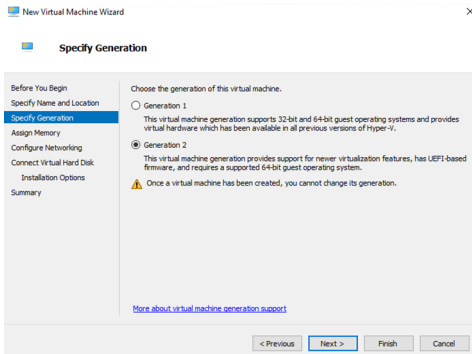

b. In Step 9, click *Browse* and locate the *.vhd file that you converted from fortipam.vhd.

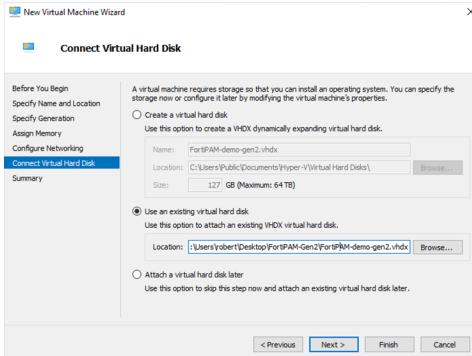

c. In step 14 (a, b, and c), click *SCSI Controller*, select *Hard Drive*, and click *Add*.

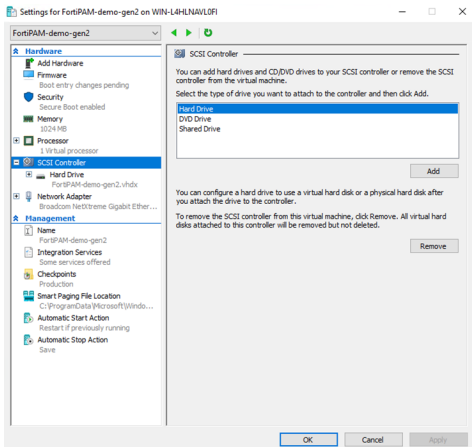

d. In step 14 d, in *Hard Drive*, click *Browse* and locate the *.vhd file for DATADRIVE1.vhd that you earlier converted in *Converting hard disk to *.vhd*.

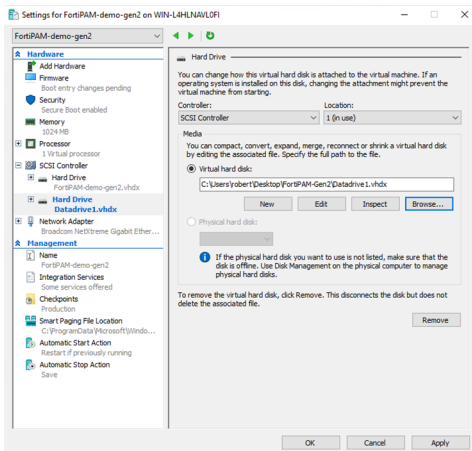

- e. Repeat steps c and d to add *.vhdx file for DATADRIVE2.vhd.

Secure boot must be disabled before starting the VM.

To disable secure boot:

1. From the virtual machines list, right-click the VM and select *Settings*. Optionally, having select the VM, select *Action* and then select *Settings*.
2. Go to *Security* and uncheck *Enable Secure Boot*.
3. Click *Apply*.

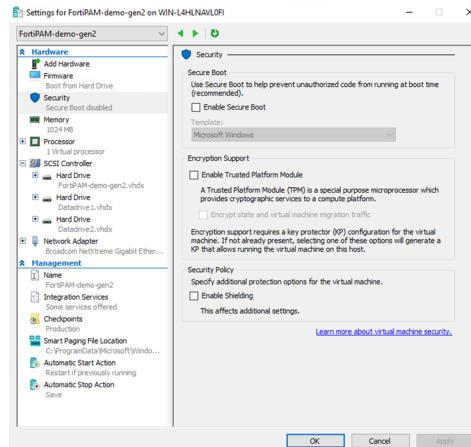

4. Click *OK*.

3. Enabling TPM on Hyper-V:



Ensure that TPM is set up as part of the initial configuration, i.e., before powering on the FortiPAM-VM for the first time.

- a. From the virtual machines list, right-click the VM and select *Settings*. Optionally, having select the VM, select *Action* and then select *Settings*.
- b. Go to *Security* and check *Enable Trusted Platform Module*. Optionally, enable *Encrypt state and virtual machine migration traffic*.

c. Click *Apply*.

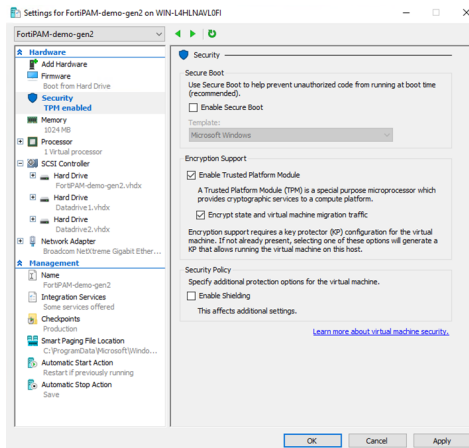

d. Click *OK*.

You can now power on your VM.

Appendix G: Installation on Azure

If deploying FortiPAM from the Marketplace, skip to [Creating the FortiPAM-VM on page 423](#).

Uploading the VHD file to an Azure storage account

To upload the VHD file to an Azure storage account:

1. Unzip the `FPA_AZURE-v100-buildXXXX-FORTINET.out.hyperv.zip` file and store the `fortipam.vhd` file on your management computer.
2. Go to your storage account on the [Microsoft Azure Portal](#) and click *Upload*.

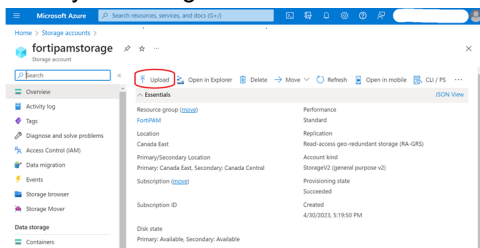

The *Upload blob* window opens.

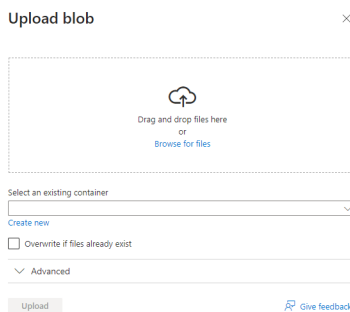

3. Select *Browse for files* and locate the `fortipam.vhd` file that you downloaded and unzipped in step 1.
4. Click *Upload*.

Creating an image on Azure Images

To create an image:

1. Go to *Images* on the Azure Portal and select *Create*.

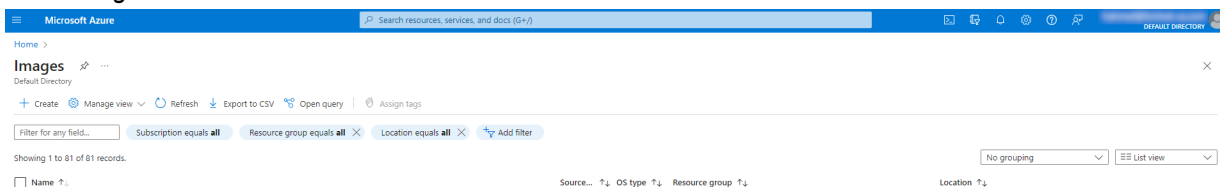

The *Create an image* wizard opens.

2. From the *Resource group* dropdown, select a resource group.
3. In *Name*, enter the name for the image.
4. In the *Region* dropdown, select a region.
5. In *OS type*, select *Linux*.
6. In *VM generation*, you can select *Gen 1* or *Gen 2*.



Gen 1 VMs use BIOS-based architecture, whereas *Gen 2* VMs use the new UEFI-based boot architecture.

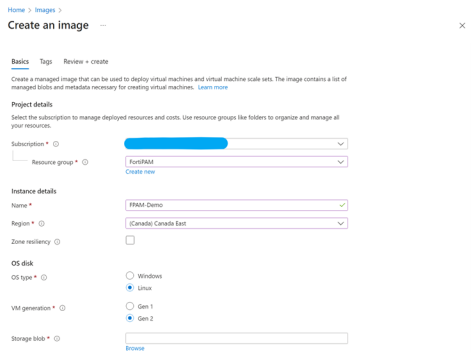

7. In the *Storage blob*, click *Browse*, locate the `fortipam.vhd` file that you uploaded to your storage account in [Uploading the VHD file to an Azure storage account on page 422](#), and click *Next : Tags*.
8. Optionally, in *Tags*, enter tags, and click *Next : Review + Create*.
9. Review your settings and then click *Create*.
Note: The deployment may take several minutes to finish.

Creating the FortiPAM-VM

To create the FortiPAM-VM:

1. On the Azure Portal, open the image you created in [Creating an image on Azure Images on page 422](#), and click *Create VM*.

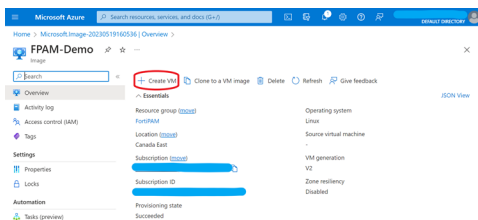

Alternatively, go to the *Marketplace* on the Azure Portal and look for FortiPAM.

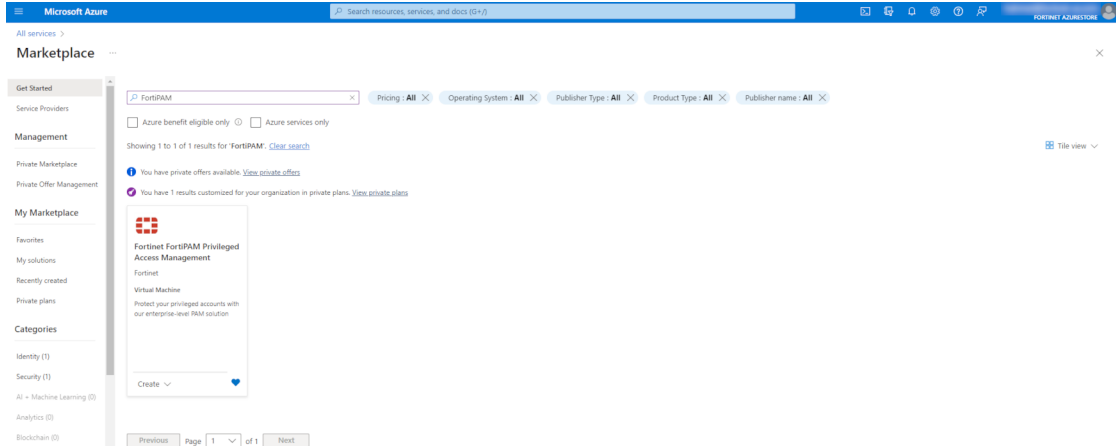

Click on the *Fortinet FortiPAM Privileged Access Management* card and select *Create*. The *Create a virtual machine* wizard opens.

2. In *Virtual machine name*, enter a name for the VM being created.
3. In the *Region* dropdown, select a region if the region is not automatically selected.
4. In the *Image* dropdown, select the image created in [Creating an image on Azure Images on page 422](#) if the image is not automatically selected.
5. In the *Size* dropdown, select a size that supports the workload you intend to perform.

The following shows a screenshot when FortiPAM is deployed using the image you created in [Creating an image on Azure Images on page 422](#).

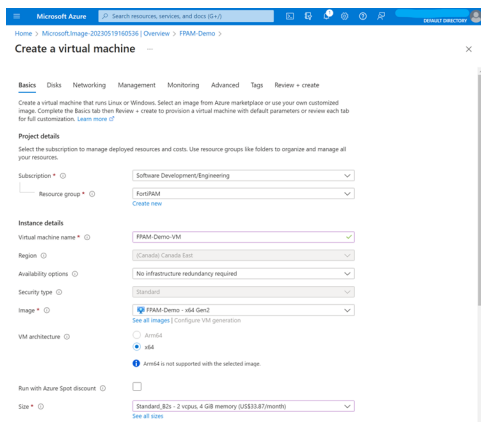

The following shows a screenshot when FortiPAM is deployed from the *Marketplace*.

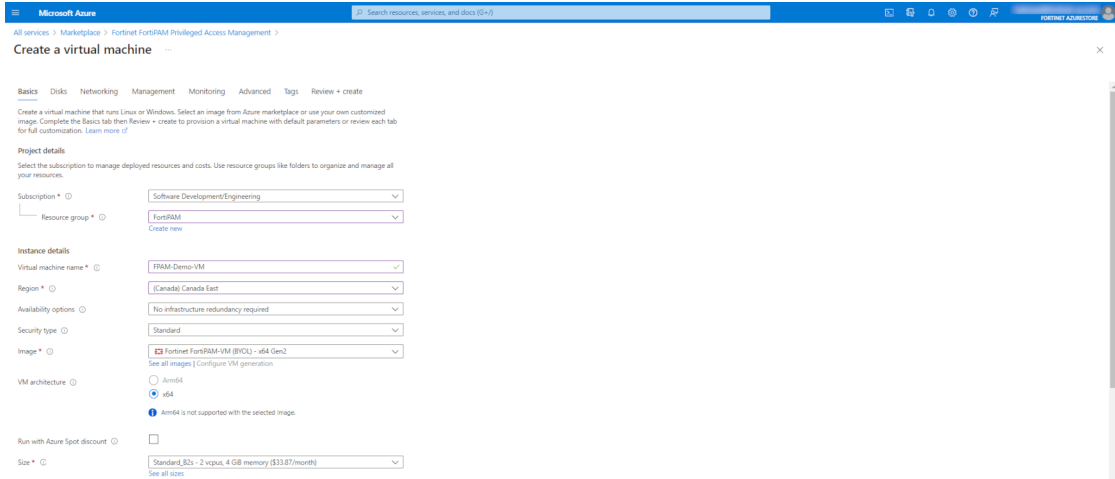

6. In the *Administrator account* pane:
 - a. In *Authentication type*, select *Password*.
 - b. In *Username*, enter a username.
 - c. In *Password*, enter the password.
 - d. In *Confirm password*, enter the password again to confirm.



The account is created with the *Super Administrator* role on FortiPAM.



7. In the *Inbound port rules* pane:
 - a. In *Public inbound ports*, select *Allow selected ports*.
 - b. In the *Select inbound ports* dropdown, select *HTTPS (443), SSH (22)*.
8. In the *License Type* dropdown, select *Other*, and click *Next*.

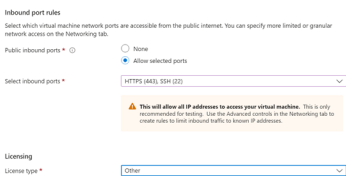

9. In *Data disks for FPAM-demo-VM*, select *Create and attach a new disk*.

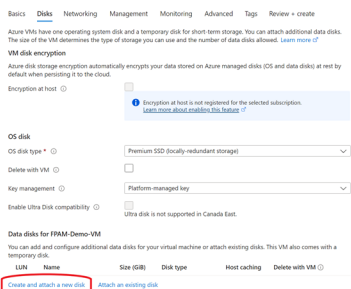

10. Create a disk for the log and another for the video, and click *Next*.



11. In the *Networking* tab:

- a. In the *Virtual network* dropdown, select a virtual network.
- b. In the *Subnet* dropdown, select a subnet.
- c. In the *Public IP* dropdown, select a public IP address or create a new public IP address.
- d. In *NIC network security group*, select *Basic*.
- e. In *Public inbound ports*, select *Allow selected ports*.
- f. In the *Select inbound ports* dropdown, select *HTTPS (443), SSH (22)*, and click *Next*.

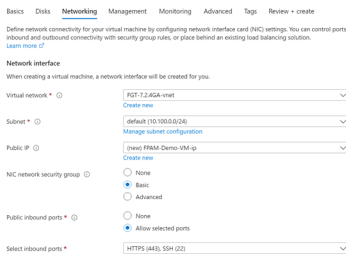

12. Click *Next* and navigate through the remaining tabs.

13. Finally, review your settings and then click *Create*.

Note: The VM deployment may take several minutes to finish.

Initial configuration

1. On the FortiPAM-VM *Networking* page, copy and save the network interface's private and public IP addresses.

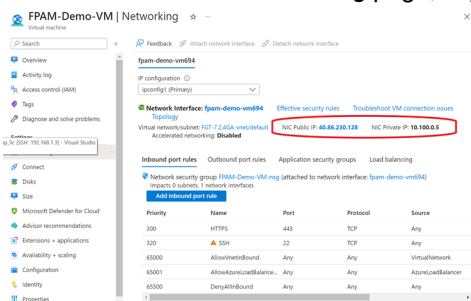

2. In the VM serial console, log in as the default super admin set up in step 6 of [Creating the FortiPAM-VM on page 423](#).

3. Using the following CLI commands, configure `port1`:



You can skip this step if FortiPAM is in standalone mode.

```
config system interface
edit port1
set mode static #by default, set as dhcp
```

```
    set ip 10.100.0.5/24 #set to the private IP address assigned by Azure in step 1
  next
end
Enable PAM Service on port1 with IP 10.100.0.5
```

When upgrading a FortiPAM instance, use the following CLI command to enable synchronizing the virtual IP address to the IP address of the external interface:

Example



```
config firewall vip
  set intf-ip-sync enable
  set extintf "port1" #The interface connected to the source network
  that receives the packets forwarded to the destination network.
end
```

When installing a new FortiPAM instance, the synchronization happens automatically.

4. Using the following CLI commands, configure a static route if the interface is configured as static mode:

```
config router static
  edit 1
    set gateway 10.100.0.1
    set device port1
  next
end
```

5. Optionally, to encrypt disk to protect logs and videos, see [Configuring log and video disk encryption on page 298](#).

6. On a web browser, go to <https://<Public IP>> to access the FortiPAM-VM GUI.

Note: The public IP address was saved in step 1.

7. Log in with the super admin username and password as set up in step 6 of [Creating the FortiPAM-VM on page 423](#).

The *FortiPAM VM license* window appears immediately after you log in.

8. In the *Upload License File* pane, select *Upload* and browse to the license file on your management computer.

9. Click *OK*.

After the boot up, the license status changes to valid.

You can now use your FortiPAM-VM deployed on Azure.



Evaluation license is not available on Azure.

Appendix H: FortiPAM hardware RAID CLI commands

The FortiPAM hardware devices 1000G and 3000G are equipped with a hardware RAID card. All the hard disks are configured in the RAID-10 group.

For the FortiPAM hardware devices, in the CLI console, check the RAID status by entering the following command:

```
diagnose system raid status
  Storcli RAID:
  RAID Level: Raid-10
  RAID Status: OK
  RAID Size: 5587GB
  Groups: 3
  Disk 0: OK 1862GB Group-1
  Disk 1: OK 1862GB Group-1
  Disk 2: OK 1862GB Group-2
  Disk 3: OK 1862GB Group-2
  Disk 4: OK 1862GB Group-3
  Disk 5: OK 1862GB Group-3
  Disk 6: Unavailable 0GB
  Disk 7: Unavailable 0GB
  Disk 8: Unavailable 0GB
  Disk 9: Unavailable 0GB
  Disk 10: Unavailable 0GB
  Disk 11: Unavailable 0GB
  Disk 12: Unavailable 0GB
  Disk 13: Unavailable 0GB
  Disk 14: Unavailable 0GB
  Disk 15: Unavailable 0GB
  .
  .
  .
```

For the FortiPAM hardware devices, in the CLI console, check the disk status by entering the following command:

```
diagnose system disk health
  Disk 0: SMART Health Status: OK
  Disk 1: SMART Health Status: OK
  Disk 2: SMART Health Status: OK
  Disk 3: SMART Health Status: OK
  Disk 4: SMART Health Status: OK
  Disk 5: SMART Health Status: OK
  Disk 6: Unavailable
  Disk 7: Unavailable
  Disk 8: Unavailable
  Disk 9: Unavailable
  Disk 10: Unavailable
  Disk 11: Unavailable
  Disk 12: Unavailable
  Disk 13: Unavailable
  Disk 14: Unavailable
  Disk 15: Unavailable
  .
  .
```

For the FortiPAM hardware devices, in the CLI console, check the disk information by entering the following command:

```
diagnose system disk info
Disk 0:
Vendor: SEAGATE
Product: ST2000NM001B
Revision: N001
Compliance: SPC-5
User Capacity: 2,000,398,934,016 bytes [2.00 TB]
Logical block size: 512 bytes
LU is fully provisioned
Rotation Rate: 7200 rpm
Form Factor: 3.5 inches
Logical Unit id: 0x5000c500d9c75b8b
Serial number: WRE06YSQ0000C246A3JM
Device type: disk
Transport protocol: SAS (SPL-3)
Local Time is: Thu Apr 13 12:12:44 2023 GMT
SMART support is: Available - device has SMART capability.
SMART support is: Enabled
Temperature Warning: Enabled
.
.
.
```

Creating a RAID-10 disk group on hardware FortiPAM



By default, FortiPAM 1000G and 3000G are configured in RAID-10.

You can recreate RAID-10 using the CLI.



Since all the data on the disks are wiped off. You must perform a backup before using this CLI command.

Use the following CLI command to create a RAID-10 disk group:

```
execute raid create-and-format
This operation will create RAID disk and format it to ext4 file system.
All existing data will be lost!
Do you want to continue? (y/n)
```

Hot swapping failed disks on FortiPAM 1000G/3000G



The following procedure was drawn from a simulated case of a failed disk. The procedure that applies to your use case may be different.

1. Unplug the disk.
2. Run the `diagnose system raid status` CLI command.
The disk status turns *Unavailable*.
3. Plug the disk back.
The disk status turns *Failed*.
4. Run the `execute raid delete \[disk-index\]` CLI command.
After a while, the disk status turns *Unused*.
5. Unplug the disk.
6. After a while, plug the disk again.
7. The disk status turns *Rebuilding*.
8. Keep FortiPAM 1000G/3000G running.
After 10 hours, the disk status turns *OK*.
RAID is recovered.

Appendix I: Default launchers parameters

The following tables list the default secret launcher executables, parameters, and initial and clean commands.

PuTTY

Executable	Parameter	Initial Commands	Clean Commands
putty.exe	\$USER@\$HOST -pw \$PASSWORD -P \$PORT		

SecureCRT

Executable	Parameter	Initial Commands	Clean Commands
secureCRT.exe	/ssh2 \$USER@\$HOST /PASSWORD \$PASSWORD /P \$PORT /AUTH password,keyboard-interactive,publickey (username and password parameter)		

Remote Desktop-Windows

Executable	Parameter	Initial Commands	Clean Commands
mstsc.exe	/V:\$TARGET:\$PORT /noConsentPrompt	<p>When the domain is used:</p> <pre>cmdkey /generic:\$TARGET /user:\$DOMAIN\USER /pass:"\$PASSWORD"</pre> <p>When the domain is not used:</p> <pre>cmdkey /generic:\$TARGET /user:\$USER /pass:"\$PASSWORD"</pre>	cmdkey /del:\$TARGET

WinSCP

Executable	Parameter	Initial Commands	Clean Commands
winscp.exe	scp://\$USER:\$PASSWORD@\$HOST:\$PORT /newinstance		

TightVNC

Executable	Parameter	Initial Commands	Clean Commands
tvnviewer.exe	\$HOST::\$PORT - PASSWORD=\$PASSWORD		

VNC Viewer

Executable	Parameter	Initial Commands	Clean Commands
vncviewer.exe	Proxy mode: \$HOST::\$PORT Non-proxy mode: - config \$TMPFILE	Non-proxy init-commands: <ol style="list-style-type: none"> 1. echo [connection] > \$TMPFILE 2. echo host=\$HOST >> \$TMPFILE 3. echo port=\$PORT >> \$TMPFILE 4. echo password=\$VNCPASSWORD >> \$TMPFILE 5. echo username=\$USER >> \$TMPFILE 	Non-proxy clean commands: cmdkey /del:\$TARGET

SSH CLI

Executable	Parameter	Initial Commands	Clean Commands
ssh.exe	\$USER@\$HOST -p \$PORT		

Microsoft SQL CLI

Executable	Parameter	Initial Commands	Clean Commands
sqlcmd.exe	-S \$HOST,\$PORT -U \$USER -P \$PASSWORD -y 30 -Y 30		

MySQL CLI

Executable	Parameter	Initial Commands	Clean Commands
mysql.exe	-u \$USER -h \$HOST -P \$PORT -p\$PASSWORD		

MySQL Shell

Executable	Parameter	Initial Commands	Clean Commands
mysqlsh.exe	--mysql --sql --result-format=json/pretty -u \$USER -h \$HOST -P \$PORT -p\$PASSWORD		

PostgreSQL CLI

Executable	Parameter	Initial Commands	Clean Commands
psql.exe	"host=\$HOST port=\$PORT dbname=postgres user=\$USER password=\$PASSWORD"		

SSMS

Executable	Parameter	Initial Commands	Clean Commands
ssms.exe	-S \$HOST, \$PORT -U \$USER	cmdkey /generic:Microsoft:SSMS:19:\$HOST, \$PORT:\$USER:8c91a03d-f9b4-46c0- a305-b5dcc79ff907:1 /user:\$USER /pass:"\$PASSWORD" See Powershell script on page 434	cmdkey /delete:Microsoft:SSMS:19:\$HOST, \$PORT:\$USER:8c91a03d-f9b4-46c0- a305-b5dcc79ff907:1

HeidiSQL

Executable	Parameter	Initial Commands	Clean Commands
heidisql.exe	1. mssql: --nettype 4 -u "\$USER" -p "\$PASSWORD" -h \$HOST --library MSOLEDBSQL -P		

Executable	Parameter	Initial Commands	Clean Commands
	\$PORT 2. nettype 0 -u "\$USER" -p "\$PASSWORD" -h \$HOST --library libmariadb.dll - P \$PORT 3. --nettype 8 -u "\$USER" -p "\$PASSWORD" -h \$HOST --library libpq-12.dll -P \$PORT		

MobaXterm

Executable	Parameter	Initial Commands	Clean Commands
mobaxterm.exe	-newtab \"ssh \$USER@\$HOST -p \$PORT\"		

Xshell

Executable	Parameter	Initial Commands	Clean Commands
Xshell.exe	-newwin ssh://\$USER@\$HOST:\$PORT		

Powershell script

```

powershell
$xmlChildName = @"
<?xml version="1.0"?>
<SqlStudio>
<ServerTypes>
<Element>
<Key>
<guid>8c91a03d-f9b4-46c0-a305-b5dcc79ff907</guid>
</Key>
<Value>
<ServerTypeItem>
<Servers>
<Element>
<Time>
<long>-638197664443740231</long>
</Time>
<Item>
<ServerConnectionItem>
<Instance>$HOST,$PORT</Instance>

```

```
<AuthenticationMethod>1</AuthenticationMethod>
<Connections>
<Element>
<Time>
<long>-638197664443691066</long>
</Time>
</Item>
<ServerConnectionSettings>
<Password/>
<Instance>$HOST,$PORT</Instance>
<UserName>$USER</UserName>
<ServerType>8c91a03d-f9b4-46c0-a305-b5dcc79ff907</ServerType>
<AuthenticationMethod>1</AuthenticationMethod>
<Database/>
<Advanced>
<Element>
<Key>
<string>IniDb</string>
</Key>
<Value/>
</Element>
<Element>
<Key>
<string>CT</string>
</Key>
<Value>
<string>30</string>
</Value>
</Element>
<Element>
<Key>
<string>ET</string>
</Key>
<Value>
<string>0</string>
</Value>
</Element>
<Element>
<Key>
<string>PSize</string>
</Key>
<Value>
<string>4096</string>
</Value>
</Element>
<Element>
<Key>
<string>EC</string>
</Key>
<Value>
<string>False</string>
</Value>
</Element>
<Element>
<Key>
<string>UCCC</string>
</Key>
```

```
<Value>
<string>False</string>
</Value>
</Element>
<Element>
<Key>
<string>CCC</string>
</Key>
<Value>
<string>-986896</string>
</Value>
</Element>
<Element>
<Key>
<string>TSC</string>
</Key>
<Value>
<string>False</string>
</Value>
</Element>
<Element>
<Key>
<string>UCTI</string>
</Key>
<Value>
<string>False</string>
</Value>
</Element>
<Element>
<Key>
<string>CTI</string>
</Key>
<Value>
<string/>
</Value>
</Element>
<Element>
<Key>
<string>CES</string>
</Key>
<Value/>
</Element>
<Element>
<Key>
<string>CESEnclave</string>
</Key>
<Value/>
</Element>
<Element>
<Key>
<string>CESProtocol</string>
</Key>
<Value/>
</Element>
<Element>
<Key>
<string>CESUrl</string>
```

```

</Key>
<Value/>
</Element>
<Element>
<Key>
<string>Prot</string>
</Key>
<Value/>
</Element>
</Advanced>
<OtherParams/>
</ServerConnectionSettings>
</Item>
</Element>
</Connections>
</ServerConnectionItem>
</Item>
</Element>
</Servers>
</ServerTypeItem>
</Value>
</Element>
</ServerTypes>
</SqlStudio>
"@
$xmlFileName =
    "C:\\Windows\\SysWOW64\\config\\systemprofile\\AppData\\Roaming\\Microsoft\\SQL
    Server Management Studio\\19.0\\UserSettings.xml"
if (-Not (Test-Path $xmlFileName)) {Copy "C:\\Users\\$LOCAL_
    USER\\AppData\\Roaming\\Microsoft\\SQL Server Management
    Studio\\19.0\\UserSettings.xml" $xmlFileName}
$xmlDoc = New-Object system.Xml.XmlDocument
$xmlDoc = Get-Content $xmlFileName
$xmlChild = $xmlChildName
$exist = $xmlDoc.SelectNodes("//Connections[Element[Item[ServerConnectionSettings
    [Instance= '$HOST,$PORT']]])")
if ([String]::IsNullOrEmpty($exist)) {
    $node = $xmlDoc.SelectSingleNode("//Element[Key[guid= '8c91a03d-f9b4-46c0-a305-
    b5dcc79ff907']]])")
    $copy = $xmlDoc.ImportNode($child.get_DocumentElement(), $true)
    if ([String]::IsNullOrEmpty($node)) {
        $node = $xmlDoc.SelectSingleNode('//ServerTypes')
        $node.ParentNode.RemoveChild($node)
        $xmlDoc.SqlStudio.SSMS.ConnectionOptions.AppendChild($copy.ServerTypes)
    } else {
        $inner = $node.Value.ServerTypeItem.Servers
        $inner.AppendChild($copy.ServerTypes.Element.Value.ServerTypeItem.Servers.Element)
    }
    $xmlDoc.Save($xmlFileName)}

```

Appendix J: Installation on AWS

FortiPAM installation on AWS and initial setup:

1. Converting qcow2 to a RAW format for AWS import-image tool on page 438
2. Creating an S3 bucket on AWS on page 439
3. Uploading RAW file to the AWS S3 bucket on page 440
4. Creating a snapshot from the RAW file in the AWS S3 bucket on page 440
5. Creating AMI from the snapshot on page 443
6. Configuring a security group on page 444
7. Launching the FortiPAM instance from AMI on page 446
8. Initial configuration on page 447
9. Licensing on page 449

Converting qcow2 to a RAW format for AWS import-image tool

To convert qcow2 to a RAW format for AWS import-image tool:

1. Unzip the `FPA_KVM_AWS-v100-buildxxxx-FORTINET.out.kvm.zip` file and locate the `fortipam.qcow2` file.
2. On a Linux machine, install `qemu-utils` package to get the `qemu-img` tool:

```
$ sudo apt-get install qemu-utils
```
3. Use `qemu-img` to convert the image into RAW format:

```
$ qemu-img convert fortipam.qcow2 fortipam.raw
```

Creating an S3 bucket on AWS

To create an S3 bucket on AWS:

1. Select *Services* and from the list on the left, go to *Storage > S3*.
2. Select *Create bucket*.

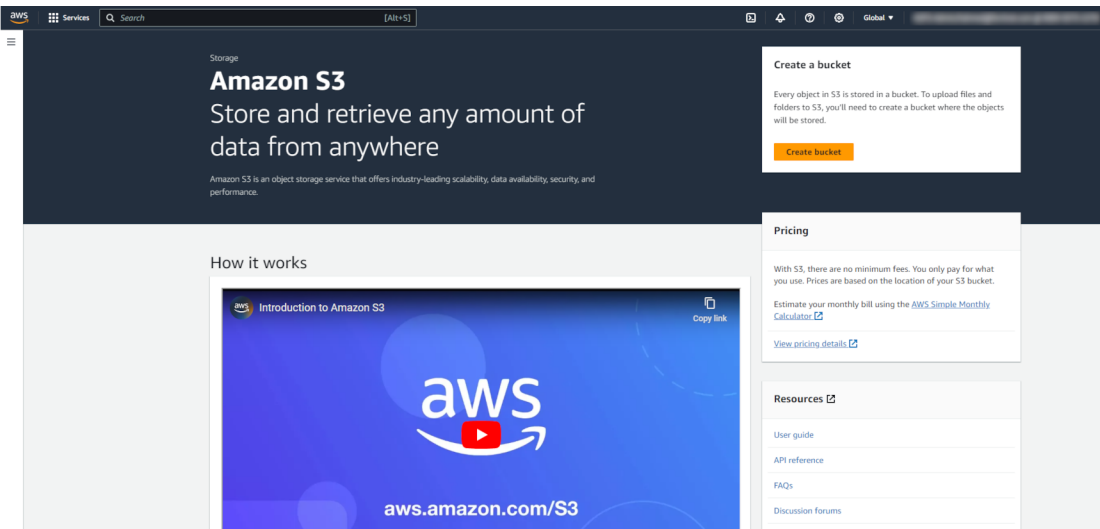

The *Create bucket* page opens.

3. In the *General* configurations pane, enter the following information:

Bucket name	The name of the bucket.
AWS Region	From the dropdown, select a region where the bucket is stored.

4. Leave all other settings on default.
5. Click *Create bucket*.

Uploading RAW file to the AWS S3 bucket

To upload RAW file to the AWS S3 bucket:

- Using the following command, install the AWS CLI :

```
$ sudo pip install awscli --ignore-installed six
```

- Using the following command, add your AWS credential to `~/.aws/config`:

```
[default]
aws_access_key_id=AKIA4I34XXXXXXXXX
aws_secret_access_key=ACR8XXXXXXXXXXXXXXXXXXXXX
region = us-west-1
```

Note: Access key can be created from *Security credentials* in your IAM Account.

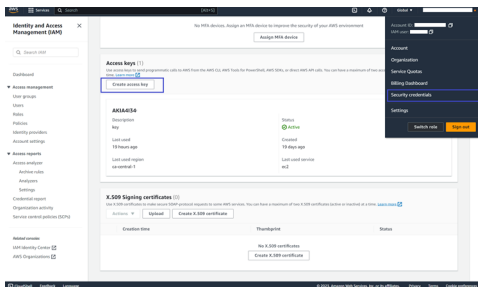

- Using the following command, copy the RAW image to the S3 bucket:

```
$ aws s3 cp fortipam.raw s3://fortipam-doc #fortipam-doc is the S3 bucket created earlier
```

Creating a snapshot from the RAW file in the AWS S3 bucket

To create a snapshot from the RAW file in the AWS S3 bucket:

- Create the `vmimport` role:
 - Create a JSON file `trust-policy.json` with the following content:

```
$ vim trust-policy.json
{
  "Version": "2012-10-17",
  "Statement": [
    {
      "Effect": "Allow",
      "Principal": {"Service": "vmie.amazonaws.com" },
      "Action": "sts:AssumeRole",
      "Condition": {
        "StringEquals": {
          "sts:Externalid": "vmimport"
        }
      }
    }
  ]
}
```

- b. Using the following AWS CLI command, create the `vmimport` role:

```
$ aws iam create-role --role-name vmimport --assume-role-policy-document  
file://trust-policy.json
```

2. Assign a policy for the S3 bucket:

- a. Create a JSON file `role-policy.json` with the following content:

```
$ vim role-policy.json  
{  
  "Version": "2012-10-17",  
  "Statement": [  
    {  
      "Effect": "Allow",  
      "Action": [  
        "s3:GetBucketLocation",  
        "s3:GetObject",  
        "s3:ListBucket"  
      ],  
      "Resource": [  
        "arn:aws:s3:::disk-image-file-bucket",  
        "arn:aws:s3:::disk-image-file-bucket/*"  
      ]  
    },  
    {  
      "Effect": "Allow",  
      "Action": [  
        "s3:GetBucketLocation",  
        "s3:GetObject",  
        "s3:ListBucket",  
        "s3:PutObject",  
        "s3:GetBucketAcl"  
      ],  
      "Resource": [  
        "arn:aws:s3:::fortipam-doc",  
        "arn:aws:s3:::fortipam-doc/*"  
      ]  
    },  
    {  
      "Effect": "Allow",  
      "Action": [  
        "ec2:ModifySnapshotAttribute",  
        "ec2:CopySnapshot",  
        "ec2:RegisterImage",  
        "ec2:Describe*"  
      ],  
      "Resource": "*"  
    }  
  ]  
}
```

- b. Using the following AWS CLI command, assign a policy for the S3 bucket:

```
$ aws iam put-role-policy --role-name vmimport --policy-name vmimport --policy-  
document file://role-policy.json
```

3. Create a JSON file `container.json` with the following content:

```
$ vim container.json
{
  "Description": "fortipam image",
  "Format": "raw",
  "UserBucket": {
    "S3Bucket": "fortipam-doc",
    "S3Key": "fortipam.raw"
  }
}
```

4. Using the following AWS CLI command, import the FortiPAM image:

```
$ aws ec2 import-snapshot --description "fortipam" --disk-container
file://container.json
{
  "Description": "fortipam",
  "ImportTaskId": "import-snap-0b087779796478a51",
  "SnapshotTaskDetail": {
    "Description": "fortipam",
    "DiskImageSize": 0.0,
    "Progress": "0",
    "Status": "active",
    "StatusMessage": "pending",
    "UserBucket": {
      "S3Bucket": "fortipam-doc",
      "S3Key": "fortipam.raw"
    }
  },
  "Tags": []
}
```

Importing the image may take some time. You can use the following AWS CLI command to monitor the progress of import:

```
$ aws ec2 describe-import-snapshot-tasks --import-task-ids import-snap-0b087779796478a51
{
  "ImportSnapshotTasks": [
    {
      "Description": "fortipam",
      "ImportTaskId": "import-snap-0b087779796478a51",
      "SnapshotTaskDetail": {
        "Description": "fortipam",
        "DiskImageSize": 2147483648.0,
        "Format": "RAW",
        "SnapshotId": "snap-0bda3d6b6d21f122c",
        "Status": "completed",
        "UserBucket": {
          "S3Bucket": "fortipam-doc",
          "S3Key": "fortipam.raw"
        }
      },
      "Tags": []
    }
  ]
}
```

Creating AMI from the snapshot

To create AMI from snapshot:

1. In the AWS console, from the *Services* menu, go to *Compute > EC2*.

2. From the menu, go to *Elastic Block Store > Snapshots* and look for the snapshot ID.



Alternatively, the `describe-import-snapshot-tasks` command used to [Monitor the progress of FortiPAM image import](#) can be used find the snapshot ID.

3. Using the following AWS CLI command, create a FortiPAM image:

```
$ aws ec2 register-image \
  --region us-west-1 \
  --name fortipam-uefi-tpm \
  --boot-mode uefi \
  --architecture x86_64 \
  --root-device-name /dev/sda1 \
  --block-device-mappings DeviceName=/dev/sda1,Ebs={SnapshotId= snap-0bda3d6b6d21f122c} \
  --tpm-support v2.0 \
  --ena-support
```

Configuring a security group

To configure a security group

1. In the AWS console, search *VPC* and select *VPC* from the search result. The *VPC dashboard* opens.

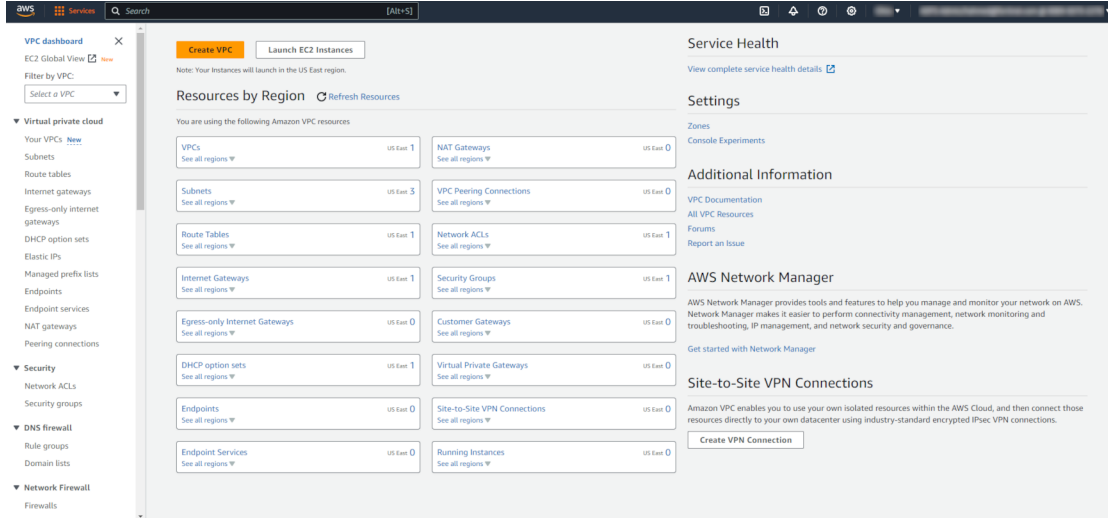

2. In the *VPC dashboard*, select *Security Groups*. The *Security Groups* window opens.

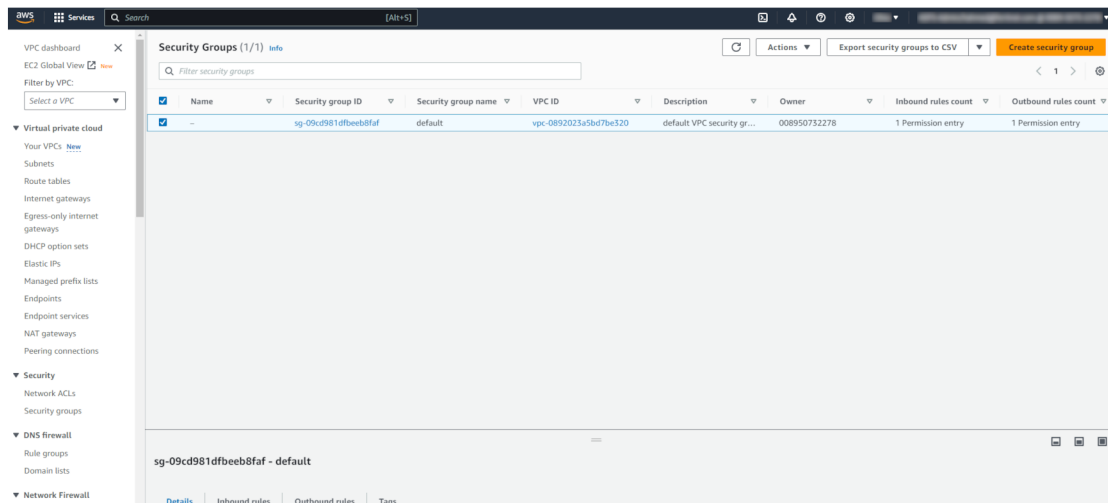

3. In the *Security Groups* window, select *Create security group*. The *Create security group* page opens.

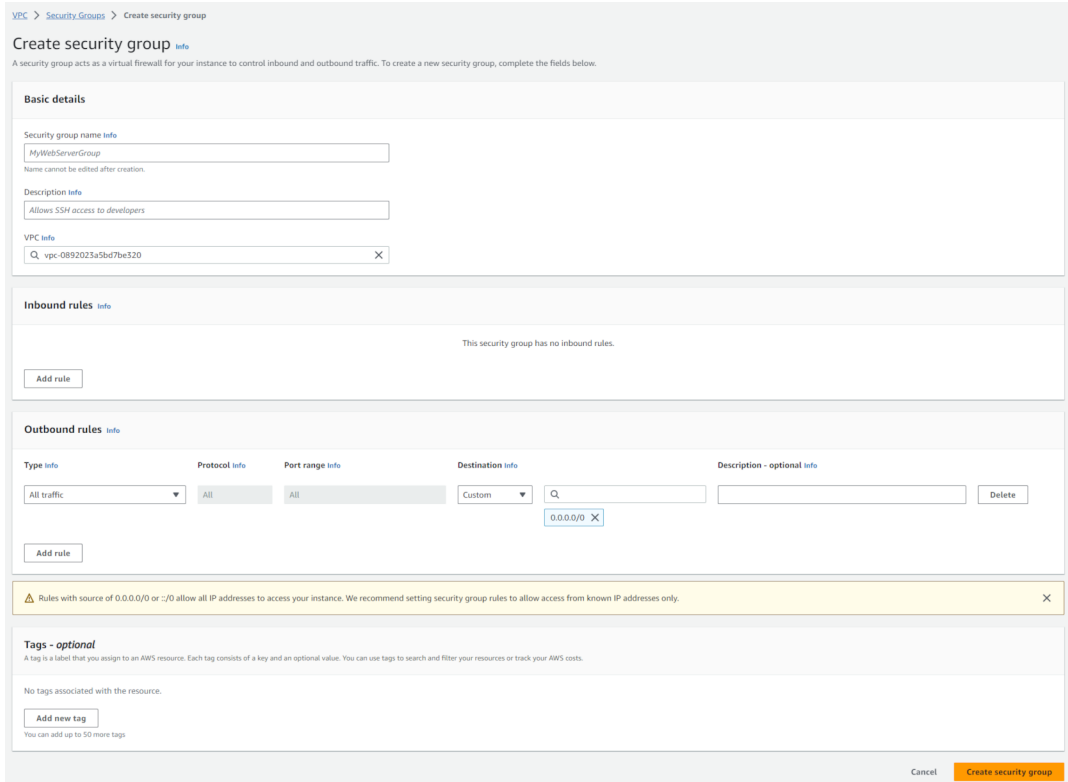

4. In the *Basic details* pane, enter the following information:

Security group name

The name of the security group.

Note: The name of the group cannot be changed after creation.

Description

The description for the security group.

VPC

Search and select the VPC in which to create the security group.

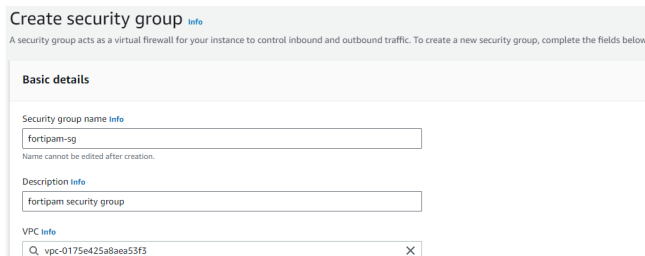

5. In the *Inbound rules* pane, add the following inbound rules:

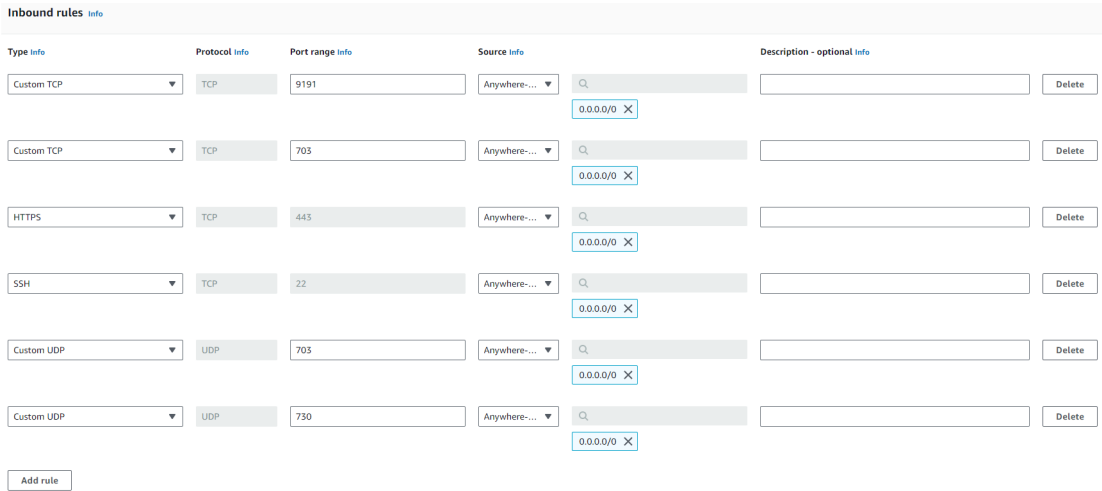

6. Use the default outbound rule that allows all the traffic.
7. Click *Create security group*.

Launching the FortiPAM instance from AMI

To launch the FortiPAM instance:

1. In the AWS console, from the *Services* menu, go to *Compute > EC2*. The *EC2 Dashboard* opens.

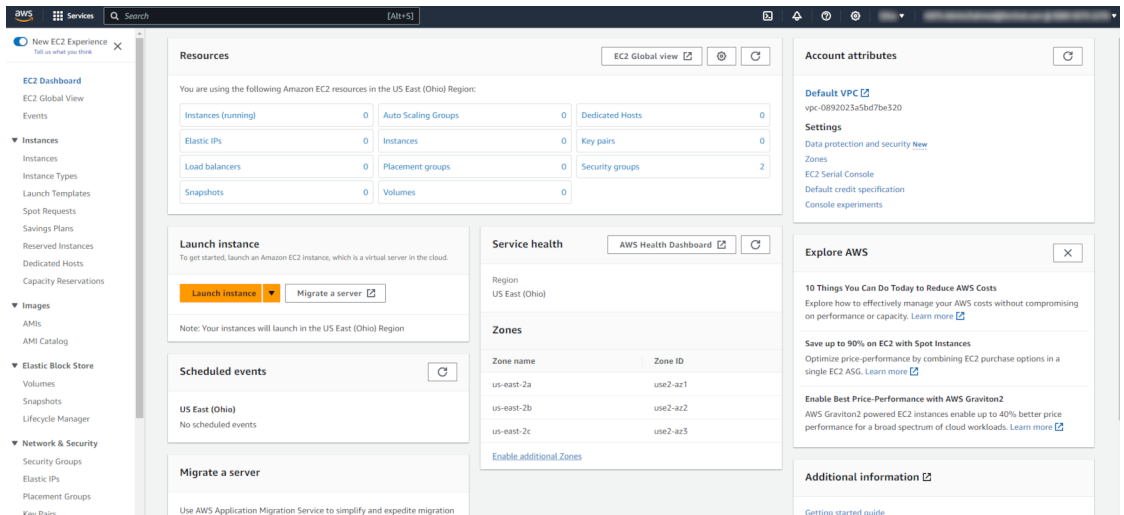

2. Go to *Images > AMIs* and select *Launch instance from AMI*. The *Launch an instance* page opens.
3. In the *Name and tags* pane, enter the name for the instance.

4. Ensure that the correct AMI is selected in the *Application and OS Images (Amazon Machine Image)* pane.

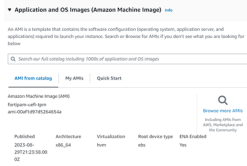

5. In the *Instance type* pane, select *m5.xlarge*.



You must choose an instance type that supports EC2 Serial Console.

6. In the *Key pair (login)* pane, from the dropdown, select *Proceed without a key pair (Not recommended)*.
7. In the *Network settings* pane:
 - a. In *Firewall (security groups)*, select *Select existing security group*.
 - b. From the *Common security groups* dropdown, select the security group created in [Configuring a security group on page 444](#).
 - c. Optionally, click *Edit* in *Network settings* to add more interfaces and choose a subnet.
8. In *Configure storage* pane:
 - a. In the field for root volume, enter 2 (in GB).
 - b. Select *Add new volume*, and in the field, enter 300 (in GB) to add a new volume for the log.
 - c. Select *Add new volume* and in the field enter 1024 (in GB) to add a new volume for video.
9. Click *Launch instance*.

Initial configuration

1. In the AWS console, search *VPC* and select *VPC* from the search result. The *VPC dashboard* opens.
2. In *Virtual private cloud* on the left, select *Elastic IPs*. The *Elastic IP addresses* window opens.

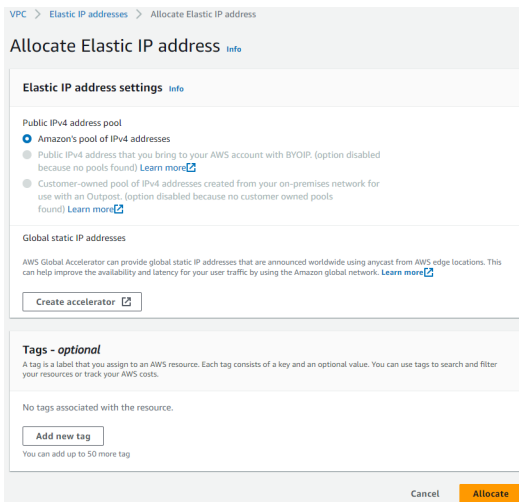

3. In the *Elastic IP addresses* window, click *Allocate* to create a new public IP address.
4. Select an IP address from the elastic IP addresses list, and from the *Actions* dropdown, select *Associate Elastic IP address*.

The *Associate Elastic IP address* page opens.

5. In *Resource type*, select *Network interface*.
6. In the *Network interface* dropdown, select a network interface.
7. In the *Private IP address* dropdown, select a private IP address.

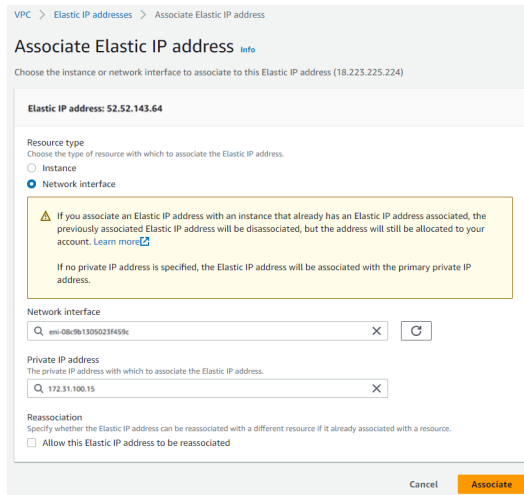

8. Click *Associate*.
9. In the AWS console, from the *Services* menu, go to *Compute > EC2*.
10. In the *EC2 Dashboard*, go to *Instances > Instances*, select the FortiPAM instance from the list, and then select *Connect*.
11. From the *EC2 serial console* tab, click *Connect*.

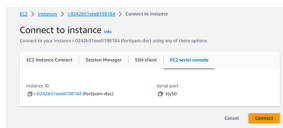

12. Log in as the administrator with the AWS instance ID password.
13. FortiPAM asks you to change your password. Enter a new password. Enter the password again to confirm.

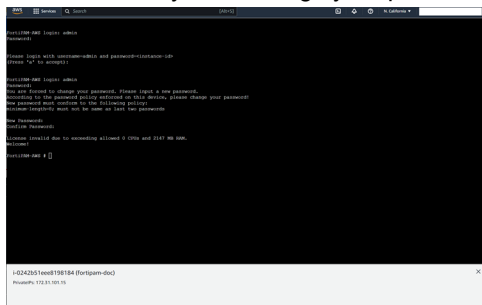

14. Use the following FortiPAM CLI commands to configure the port1, change mode from DHCP to static and set the IP address to the same as the private IP address in [steps 4 to 8](#):



You can skip this step if FortiPAM is in standalone mode.

```
config system interface
edit "port1"
```

```

set mode static #by default, set as dhcp
set ip 172.31.100.15/24 #set to the private IP address assigned by AWS in step 7
next
end

```

When upgrading a FortiPAM instance, use the following CLI command to enable synchronizing the virtual IP address to the IP address of the external interface:

Example



```

config firewall vip
set intf-ip-sync enable
set extintf "port1" #The interface connected to the source network
that receives the packets forwarded to the destination network.
end

```

When installing a new FortiPAM instance, the synchronization happens automatically.

15. Use the following FortiPAM CLI commands to configure a static route if the interface is configured as static mode:

```

config router static
edit 1
set gateway 172.31.100.1
set device port1
next
end

```

16. Optionally, use the following command to verify that you can access the public network:

```
execute ping update.fortiguard.net
```

You should receive an echo reply packet similar to the following:

```

PING fdsl.fortinet.com (208.184.237.66): 56 data bytes
64 bytes from 208.184.237.66: icmp_seq=0 ttl=52 time=3.0 ms
64 bytes from 208.184.237.66: icmp_seq=1 ttl=52 time=3.0 ms
64 bytes from 208.184.237.66: icmp_seq=2 ttl=52 time=3.0 ms
64 bytes from 208.184.237.66: icmp_seq=3 ttl=52 time=3.2 ms
64 bytes from 208.184.237.66: icmp_seq=4 ttl=52 time=3.0 ms
--- fdsl.fortinet.com ping statistics ---
5 packets transmitted, 5 packets received, 0% packet loss
round-trip min/avg/max = 3.0/3.0/3.2 ms

```

17. Optionally, to encrypt disk to protect logs and videos, see [Configuring log and video disk encryption on page 298](#).

Licensing

To successfully license FortiPAM:

1. Download the license file (.lic), see [Registering and downloading your license](#).
2. Upload the license file from the public IP address using SCP, see [Uploading the license file using SCP](#).
3. After the boot up, the license status changes to valid.

You can check the license status using the following CLI command:

```
get system status
```

```
FPAVULM23000007 # get sys status
Version: FortiPAM-AWS v1.2.0,build0681,230829 (Interim)
License: Active, seat 9, active seat 9, expiry date 2024-02-11
Virus-DB: 1.00000(2018-04-09 18:07)
Extended-DB: 1.00000(2018-04-09 18:07)
Extreme-DB: 1.00000(2018-04-09 18:07)
AV AI/ML Model: 0.00000(2001-01-01 00:00)
IPS-DB: 6.00741(2015-12-01 02:30)
IPS-RTDB: 6.00741(2015-12-01 02:30)
APP-DB: 6.00741(2015-12-01 02:30)
INDUSTRIAL-DB: 6.00741(2015-12-01 02:30)
IPS Malicious URL Database: 1.00001(2015-01-01 01:01)
Serial Number: FPAVULM23000
License Status: Valid
VM Resources: 4 CPU, 15645 MB RAM
Log hard disk: Available
Hostname: FPAVULM23000007
Private Encryption: Disable
Operation Mode: NAT
FIPS-CC mode: disable
Current HA mode: Standalone
Branch point: 0681
Release Version Information: Interim
FortiPAM x86-64: Yes
System time: Wed Aug 30 11:27:44 2023
Last reboot reason: warm reboot
```

4. Optional- Customize VIP if default VIP is not preferred:

```
config firewall vip
edit "fortipam_vip"
set extip 172.31.100.15 #external visible virtual IP address
next
end
```

5. You can now use your FortiPAM-VM deployed on AWS.

On a web browser, go to <https://<Public IP>> to access the FortiPAM-VM GUI. This is the same IP address set up in step 4 above.

Appendix K: Installation on GCP

FortiPAM installation on GCP and initial setup:

1. Creating a cloud storage bucket on GCP on page 451
2. Adding the FortiPAM image file to the storage bucket on page 452
3. Creating a FortiPAM image on GCP on page 453
4. Creating VM instance from the image on page 455
5. Licensing on page 459
6. Static interface IP address on page 460
7. Setting up HA on page 461
8. Enabling vTPM on page 463

Creating a cloud storage bucket on GCP

To create a cloud storage bucket on GCP:

1. From the navigation pane, go to *Cloud Storage > Bucket*.
The *Buckets* window opens.

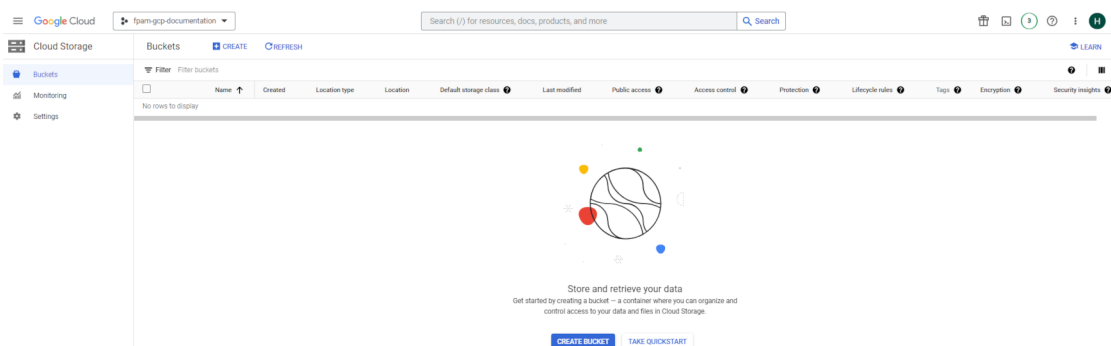

2. Select **+CREATE/CREATE BUCKET** to create a new storage bucket.

A screenshot of the 'Create a bucket' form in the Google Cloud console. The form has several sections: 'Name your bucket' with a text input field containing 'Eg. 'example', 'example_bucket-1', or 'example.com'' and a 'CONTINUE' button; 'Choose where to store your data' with 'Location: us (multiple regions in United States)' and 'Location type: Multi-region'; 'Choose a storage class for your data' with 'Default storage class: Standard'; 'Choose how to control access to objects' with 'Public access prevention: On' and 'Access control: Uniform'; and 'Choose how to protect object data' with 'Protection tools: None' and 'Data encryption: Google-managed'. At the bottom are 'CREATE' and 'CANCEL' buttons.

3. In *Name*, enter a name for the storage bucket, and click *CONTINUE*.

4. In *Choose where to store your data*, select *Multi-region*, from the dropdown select a location, and click *CONTINUE*.
5. In *Choose a storage class for your data*, keep the default settings, and click *CONTINUE*.
6. In *Choose how to control access to objects*, keep the default settings, and click *CONTINUE*.
7. In *Choose how to protect object data*, keep the default settings, and click *CONTINUE*.
8. Select *Create*.

The storage bucket is created.

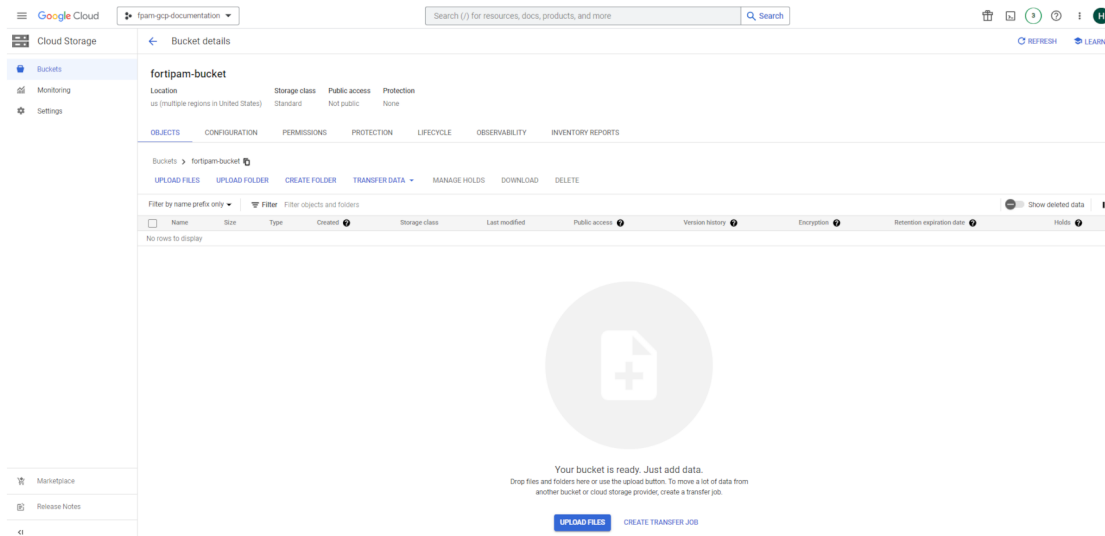

Adding the FortiPAM image file to the storage bucket

To add the FortiPAM image file to the storage bucket:

1. From the navigation pane, go to *Cloud Storage > Bucket*.
2. In the *Buckets* window, click the name of the storage bucket created in [Creating a cloud storage bucket on GCP on page 451](#) to open it.

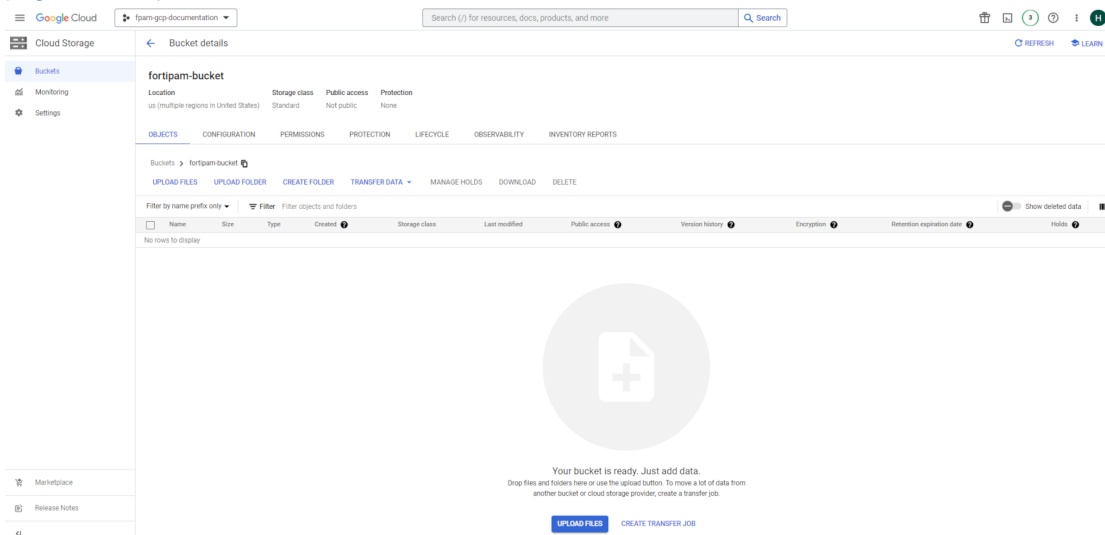

3. Select *UPLOAD FILES*, locate the FortiPAM image file from your management computer, and click *Open*. The FortiPAM image file is successfully uploaded to the storage bucket.

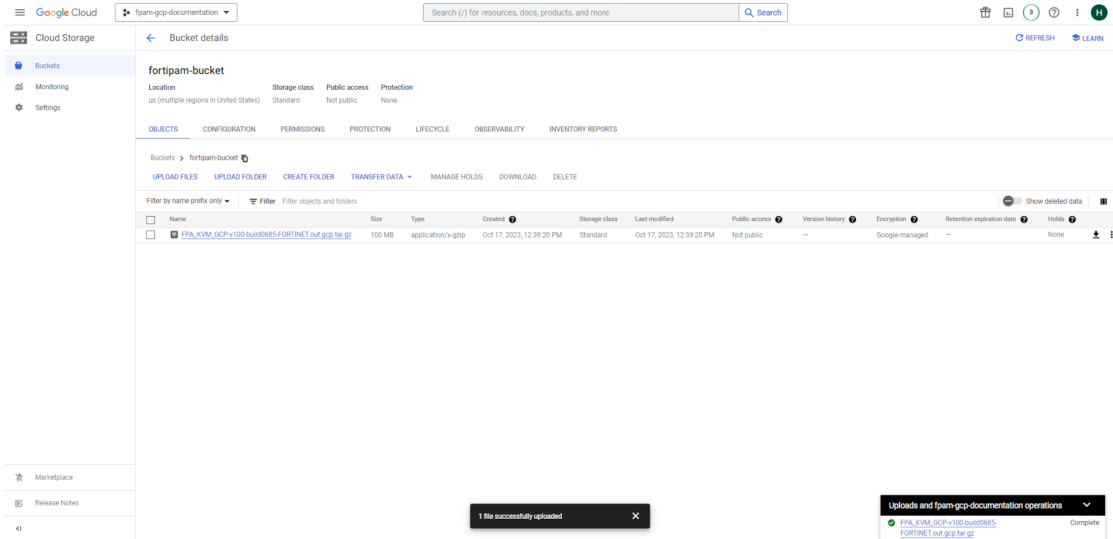

Creating a FortiPAM image on GCP



If you want to use vTPM, see [Enabling vTPM on page 463](#) to create an image.

To create a FortiPAM image on GCP:

1. From the navigation pane, go to *Compute Engine > Storage > Images*. The *Images* window opens.

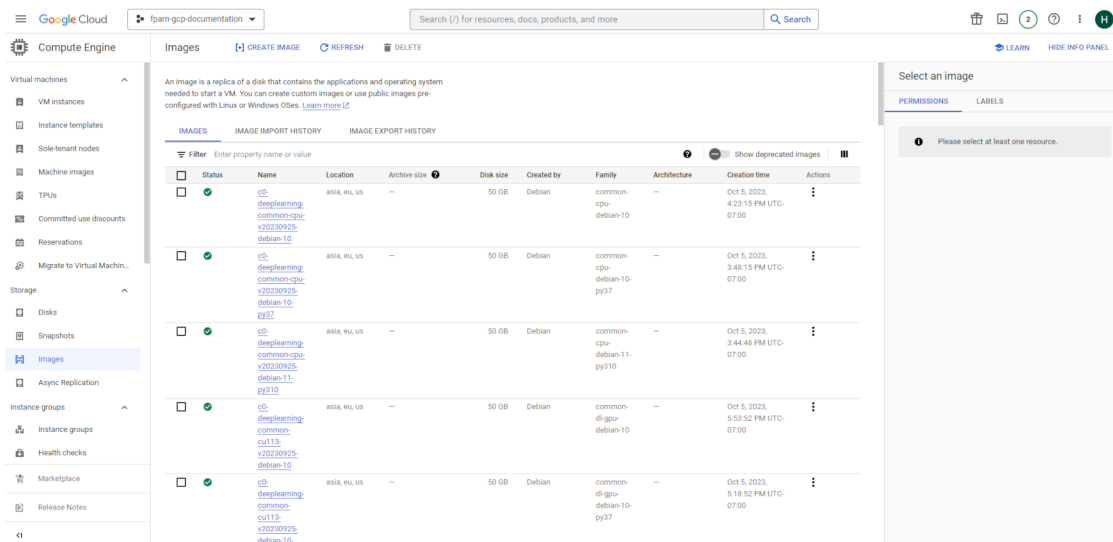

2. In the *Images* window, select *Create Image*, and click *CONTINUE*. The *Create an image* window opens.

Create an image

Name *
image-1
Name is permanent

Source *
Disk

Source disk *

Location

Multi-regional
 Regional

Select location

Family

Description

Labels
+ ADD LABEL

Encryption
Data is encrypted automatically. Select an encryption key management solution.

Google-managed encryption key
No configuration required

Customer-managed encryption key (CMEK)
Manage via [Google Cloud Key Management Service](#)

Customer-supplied encryption key (CSEK)
Manage outside of Google Cloud

CREATE CANCEL EQUIVALENT CODE

3. In *Name*, enter a name for the image.
4. In the *Source* dropdown, select *Cloud Storage file*.
5. Select *BROWSE*, from the *Select object* pane that opens, go to the FortiPAM image file, and click *SELECT*.



The image source must have `.tar.gz` as its extension and the file in it must be named `disk.raw`.

6. Ensure that the *Location* is set to *Multi-regional*.
7. Leave the rest of the settings in the default state.

Create an image

Name *
image-fortipam
Name is permanent

Source *
Cloud Storage file

Cloud Storage file *
fortipam-bucket/FPA_KVM_GCP-v100-build0685-FORTINET.out BROWSE

Your image source must use the `.tar.gz` extension and the file inside the archive must be named `disk.raw`. [Learn more](#)

Location

Multi-regional
 Regional

Select location
us (multiple regions in United States)

Family

Description

Labels
+ ADD LABEL

Encryption
Data is encrypted automatically. Select an encryption key management solution.

Google-managed encryption key
No configuration required

Customer-managed encryption key (CMEK)
Manage via [Google Cloud Key Management Service](#)

Customer-supplied encryption key (CSEK)
Manage outside of Google Cloud

CREATE CANCEL EQUIVALENT CODE

8. Click *CREATE*.
The new FortiPAM image is now listed at the top in the *Images* window.

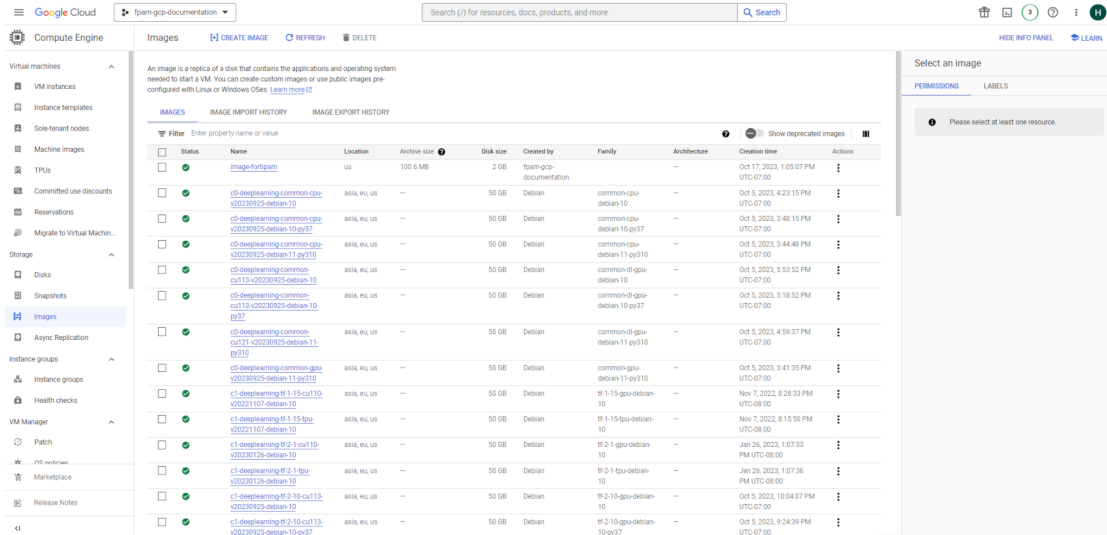

Creating VM instance from the image

To create VM instance from the image:

1. From the navigation pane, go to *Compute Engine > VM instances*. The *VM instances* window opens.

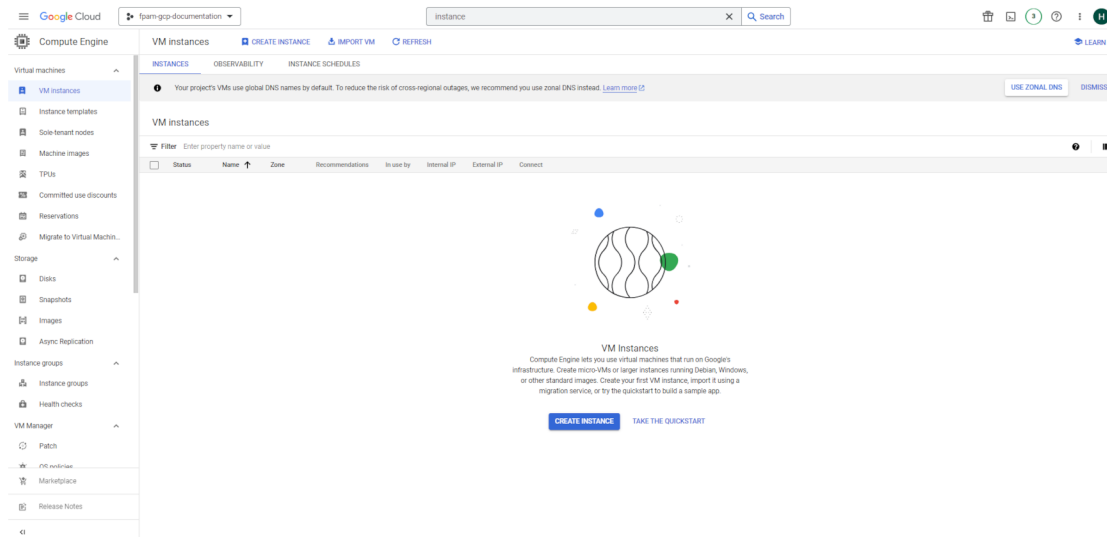

2. Select **CREATE INSTANCE**. The *Create an instance* window opens.

The screenshot shows the 'Create an instance' wizard in Google Cloud. The 'Name' field is 'Instance-1'. The 'Region' is 'us-central1 (Iowa)' and the 'Zone' is 'us-central1-a'. Under 'Machine configuration', the 'Machine type' is 'e2-medium (2 vCPU, 1 core, 4 GB memory)'. Under 'Boot disk', the 'Image' is 'Debian GNU/Linux 11 (bullseye)'. The 'Service account' is 'Compute Engine default service account'. The 'Access scopes' are set to 'Allow default access'. The 'Firewall' and 'Observability - Ops Agent' options are unchecked. The 'Advanced options' section is partially visible. At the bottom, there are 'CREATE', 'CANCEL', and 'EQUIVALENT CODE' buttons.

3. In *Name*, enter a name for the VM instance.
4. From the *Region* dropdown, select a region where the resource is located.
5. From the *Zone* dropdown, select a zone within the region where the resource is located.
6. In *Machine configuration*, select a machine type for deployment.
7. In *Boot disk*, select *CHANGE*:
 - a. Switch to the *CUSTOM IMAGES* tab.
 - b. From the *Image* dropdown, select the image created in [Creating a FortiPAM image on GCP on page 453](#).

c. Click **SELECT**.

Boot disk ⌵

Name	instance-fpa-1
Type	New balanced persistent disk
Size	10 GB
License type	Free
Image	image-fortipam

[CHANGE](#)

8. Leave the following settings in the default state:

- **ADVANCED CONFIGURATIONS**
- **Display device**
- **Confidential VM service**
- **Container**
- **Identity and API access**
- **Firewall**
- **Observability - Ops Agent**

The screenshot shows the Google Cloud console interface for creating a new VM instance. The 'Machine configuration' section is expanded to show 'ADVANCED CONFIGURATIONS'. The 'Machine type' is set to 'e2-medium (2 vCPU, 4 GB memory)'. The 'Boot disk' section at the bottom is also visible, showing the same settings as in the previous screenshot.

9. Expand **Advanced options > Networking**:

- a. In **Network interfaces**, ensure that a network interface with a subnetwork is selected.

Network interfaces ⌵

Network interface is permanent

test-vm test-vm-fortipam (10.110.0.0/24)	⌵
--	---

[ADD A NETWORK INTERFACE](#)

- b. In *Network interfaces*, add another network if the FortiPAM will be used in an HA cluster.

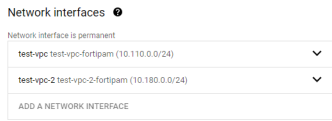

10. Expand *Advanced options > Disks*:

We create two disks; one for storing logs and the other for storing videos.

- a. Select **+ADD NEW DISK**.

The *Add new disk* pane opens.

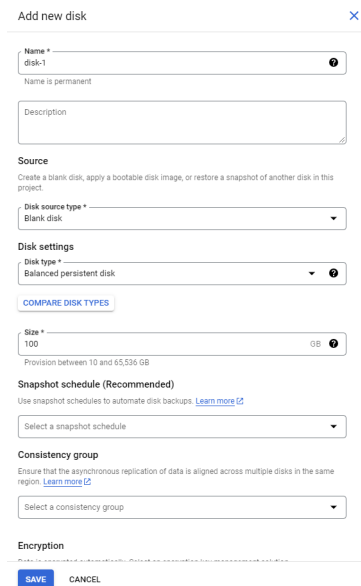

- b. In *Name*, enter a name for the disk.
- c. In *Size*, enter 10 (in GB) to add a new volume for the log.
- d. Leave the remaining settings in the default state.
- e. Click **Save**.
- f. Repeat steps a to e to add a new volume for storing videos.

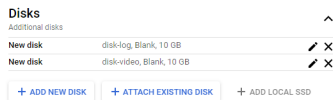

11. Click **CREATE**.

- 12. From the VM instance list, click the name of the VM instance you created. The instance page opens.

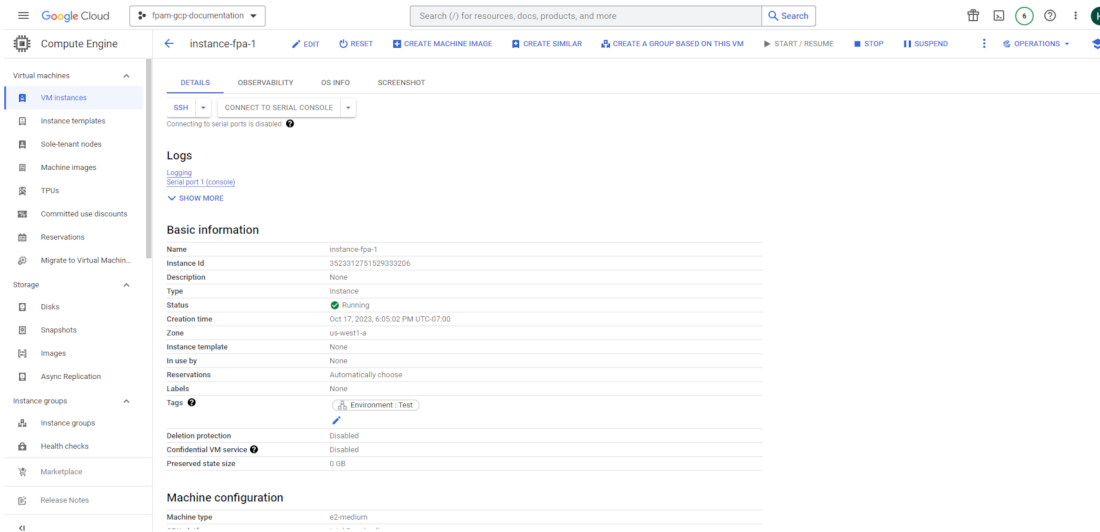

13. Select **EDIT** and in **Remote access**, select **Enable connecting to serial ports**.

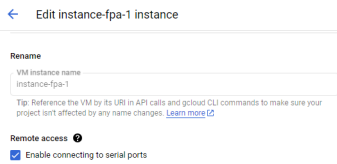

14. Click **SAVE**.

15. In the instance page, select **CONNECT TO SERIAL CONSOLE**.

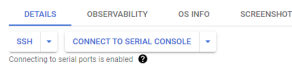

The SSH serial console opens.

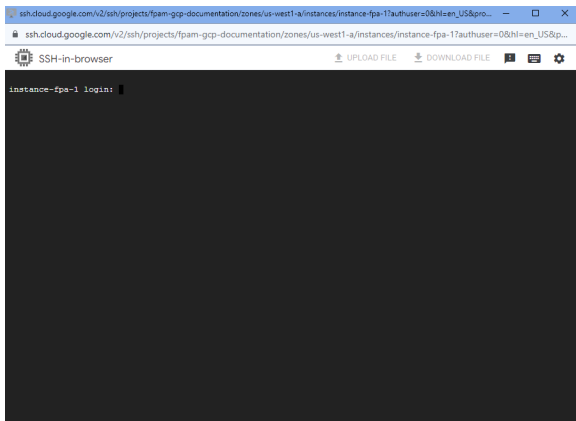

16. Use **admin** as the username and the **Instance Id** to log in for the first time.

Licensing

To successfully license FortiPAM:

1. Download the license file (.lic), see [Registering and downloading your license](#).
2. Upload the license file from the public IP address using SCP, see [Uploading the license file using SCP](#).

- FortiPAM reboots. After a few minutes, the license status changes to valid. You can check the license status using the following CLI command:

```
get system status
```

Static interface IP address

You must use a static IP address if you intend to form an HA cluster.

To find out the static IP addresses that GCP has assigned to the interfaces:

- From the navigation pane, go to *Compute Engine > VM instances*.
- From the VM instances list, click the name of the VM instance you created.
- In the *Network interfaces* pane, you see the static IP addresses assigned to the interfaces used in [Creating VM instance from the image on page 455](#).

Note down the IP addresses.

Network interfaces			
Name ↑	Network	Subnetwork	Primary internal IP address
nic0	test-vpc	test-vpc-fortipam	10.110.0.3
nic1	test-vpc-2	test-vpc-2-fortipam	10.180.0.2

To configure port1, change mode from DHCP to static and set the IP address:



You can skip this step if FortiPAM is in standalone mode.

- In the FortiPAM CLI console, enter the following commands:

```
config system interface
edit port1
set mode static #by default set as dhcp
set ip 10.110.0.3/32 #set to the IP address assigned by GCP
next
end
```

When upgrading a FortiPAM instance, use the following CLI command to enable synchronizing the virtual IP address to the IP address of the external interface:

Example



```
config firewall vip
set intf-ip-sync enable
set extintf "port1" #The interface connected to the source network
that receives the packets forwarded to the destination network.
end
```

When installing a new FortiPAM instance, the synchronization happens automatically.

To configure a static route if the interface is configured as static mode:

1. In the FortiPAM CLI console, enter the following commands:

```
config router static
edit 1
set device port1
set gateway 10.110.0.1
next
end
```

To verify access to the public network:

1. Optionally, in the FortiPAM CLI console, enter the following command:

```
execute ping update.fortiguard.net
```

You should receive an echo reply packet similar to the following:

```
PING fdsl.fortinet.com ( ): 56 data bytes
64 bytes from : icmp_seq=0 ttl=61 time=1.4 ms
64 bytes from : icmp_seq=1 ttl=61 time=0.7 ms
64 bytes from : icmp_seq=2 ttl=61 time=2.4 ms
64 bytes from : icmp_seq=3 ttl=61 time=0.3 ms
64 bytes from : icmp_seq=4 ttl=61 time=1.0 ms

--- fdsl.fortinet.com ping statistics ---
5 packets transmitted, 5 packets received, 0% packet loss
round-trip min/avg/max = 0.3/1.1/2.4 ms
```



Optionally, to encrypt disk to protect logs and videos, see [Configuring log and video disk encryption on page 298](#).

Optional- To customize VIP if default VIP is not preferred:

1. In the FortiPAM CLI console, enter the following commands:

```
config firewall vip
edit "fortipam_vip"
set extip 10.110.0.3 #external visible virtual IP address
next
end
```

You can now use your FortiPAM-VM deployed on GCP.

On a web browser, go to <https://<Public IP>> to access the FortiPAM-VM GUI. This is the same IP address set up above.

Setting up HA

Prerequisites

To deploy and configure FortiPAM as an Active-Passive HA solution, you need the following:

- Availability to accommodate the required GCP resources:
 - Four network/subnets
 - Ensure that the two FortiPAM devices have connectivity to each other on each network.
 - Appropriate ingress/egress firewall rules for relevant networks (same as a single FortiPAM-VM deployment).
 - Three public (external) IP addresses:

- One for traffic to/through the active (primary) FortiPAM. At the event of failover, this IP address will move from the primary FortiPAM to the secondary. This must be a static external IP address. It should be reserved/created before creating FortiPAM instances, or promote an ephemeral IP to a static one after deployment. See [Reserving a Static External IP Address](#).
- Two for management access to each FortiPAM. They can be ephemeral IP address, but static ones are highly recommended. See [IP Addresses](#).
- All internal IP addresses must be static, not DHCP. You should change ephemeral IP addresses to static ones after deployment. See [Reserving a Static Internal IP Address](#).
- Two FortiPAM-VM instances:
 - The two nodes must be deployed in the same region/zone.
 - Each FortiPAM-VM must have at least four network interfaces.
 - Each FortiPAM-VM should have a log disk attached. Log disks should be created before deploying FortiPAM instances. This is the same requirement as when deploying a single FortiPAM-VM.
 - Machine types that support at least four network interfaces. [Creating Instances with Multiple Network Interfaces](#).
 - Two valid FortiPAM-VM BYOL licenses. See [Licensing on page 41](#).
- You must configure an SDN connector with GCP on the primary FortiPAM:

```
config system sdn-connector
  edit "gcp_conn"
  set type gcp
  set ha-status enable
  config external-ip
    edit "reserve-fpamhapublic"
    next
  end
  config route
    edit "route-internal"
    next
  end
end
```

To set up a FortiPAM HA cluster:

1. To form an HA cluster, deploy two FortiPAM-VMs separately by following 1 - 6 in [FortiPAM installation on GCP and initial setup](#).
2. As shown in [Static interface IP address on page 460](#), note down the external IP addresses assigned to `nic0` for each FortiPAM. These are then used in step 3.
3. Connect to the primary FortiPAM external IP address using SSH, then enter the following CLI commands:

```
config system ha
  set group-name <choose a group name for the cluster>
  set mode active-passive
  set password <your-ha-password>
  set hbdev "port3" 100
  set ha-mgmt-status enable
  config ha-mgmt-interfaces
    edit 1
      set interface "port4"
      set gateway <ip address of MGMT network intrinsic router>
    next
```

```

end
set override enable
set priority 255
set unicast-status enable
set unicast-gateway 10.4.100.254
config unicast-peers
edit 1
set peer-ip 10.4.100.12
next
end
end
config system sdn-connector
edit "gcp_conn"
set type gcp
set ha-status enable
config external-ip
edit "reserve-fpamhapublic"
next
end
config route
edit "route-internal"
next
end
next
end

```

4. On the primary FortiPAM, enter the following CLI commands so that the interface IP address or the firewall VIP is not synchronized:

```

config system vdom-exception
edit 1
set object system.interface
next
edit 2
set object firewall.vip
next
end

```



This configuration is automatically synchronized once the secondary has been configured.

Enabling vTPM

To enable vTPM:

1. Add the FortiPAM image file to the storage bucket. See [Adding the FortiPAM image file to the storage bucket on page 452](#).
2. From the top-right, select *Activate Cloud Shell*.
The *CLOUD SHELL Terminal* opens.

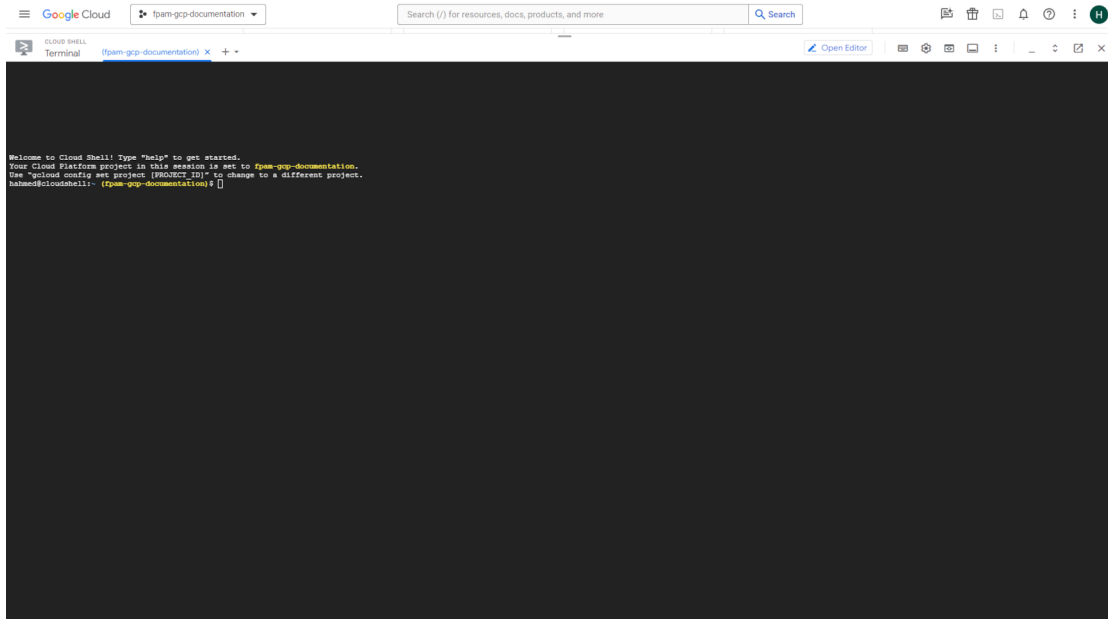

3. In the terminal, use the following commands to create a FortiPAM image:

```
gcloud compute --project={project-name} images create gcp-fpa-{buildnum}-shielded --
source-uri=https://storage.googleapis.com/{Bucket-name}/image.out.gcp.tar.gz --guest-os-
features=UEFI_COMPATIBLE,GVNIC
```

For example:

```
gcloud compute --project=fpam-gcp-documentation images create fpam-gcp-120-ga-shielded
--source-uri=https://storage.googleapis.com/fortipam-bucket/FPA_KVM_GCP-v100-build0697-
FORTINET.out.gcp.tar.gz --guest-os-features=UEFI_COMPATIBLE,GVNIC
```

A new image is created in *Compute Engine > Storage > Images*.

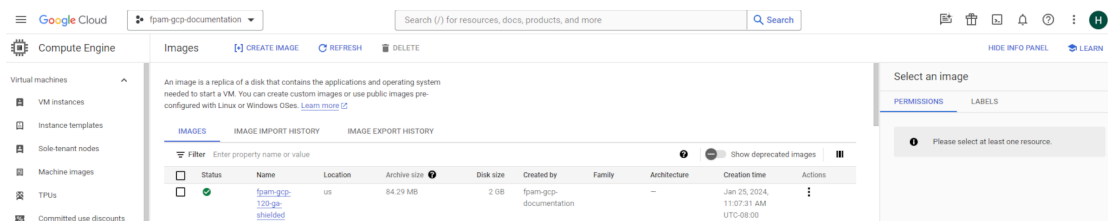

4. Create the FortiPAM VM using the image created in step 3. See [Creating VM instance from the image on page 455](#). When creating the VM, in *Advanced options > Security*, ensure that *Turn on vTPM* and *Turn on Integrity Monitoring* is enabled.

5. Once the VM is ready, in the SSH serial console, enter the following commands to verify that vTPM is enabled:

```
diagnose tpm selftest
```

The following message appears if vTPM was successfully set up:

```
Successfully tested. Works as expected.
```

Appendix L: WinRM configuration for Windows server

WinRM is needed for agentless RDP session log retrieving.

Use the commands as shown below to enable WinRM and set authentication on the target Windows servers.

1. [Configuring Windows server on page 465](#)
2. [Configuring firewall rules for WinRM on page 465](#)
3. [Creating a privileged account on page 466](#)
4. [Setting up audit policy for RDP log retrieval on page 469](#)

Configuring Windows server

To configure Windows server:

1. Open the Windows PowerShell console as an administrator and enter the following commands to enumerate the listeners:

```
PS C:\Users\xxx> winrm quickconfig
PS C:\Users\xxx> winrm set winrm/config/service '@{AllowUnencrypted="true"}'
PS C:\Users\xxx> winrm enumerate winrm/config/listener
```

2. After enumerating the listeners, if HTTPS listener is not enabled, run the following command:

```
PS C:\Users\xxx> New-SelfSignedCertificate -Subject 'CN=<windows host name>' -
TextExtension '2.5.29.37={text}1.3.6.1.5.5.7.3.1'

PS C:\Users\xxx> winrm create winrm/config/Listener?Address=*&Transport=HTTPS '@
{Hostname="<windows host name>"; CertificateThumbprint="<thumbprint received by New-Self
Signed Certificate>"}'

PS C:\Users\xxx> winrm quickconfig -transport:https
PS C:\Users\xxx> winrm enumerate winrm/config/listener
```



Single quotes are required for Windows 2016 and later.

Configuring firewall rules for WinRM

On some Windows servers and cloud platforms, the WinRM traffic (5985 for HTTP, 5986 for HTTPs) can be blocked by default.

Ensure that WinRM traffic is allowed for RDP log retrieving.

To enable Windows Remote Management:

1. On the target Windows server, go to *Control Panel > System and Security > Windows Defender Firewall*.

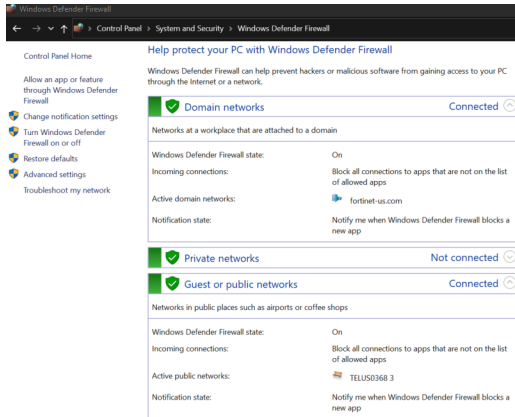

2. From the menu on the left, select *Advanced settings*.
3. In the *User Account Control* dialog that opens, click *Yes*.
A new window opens.

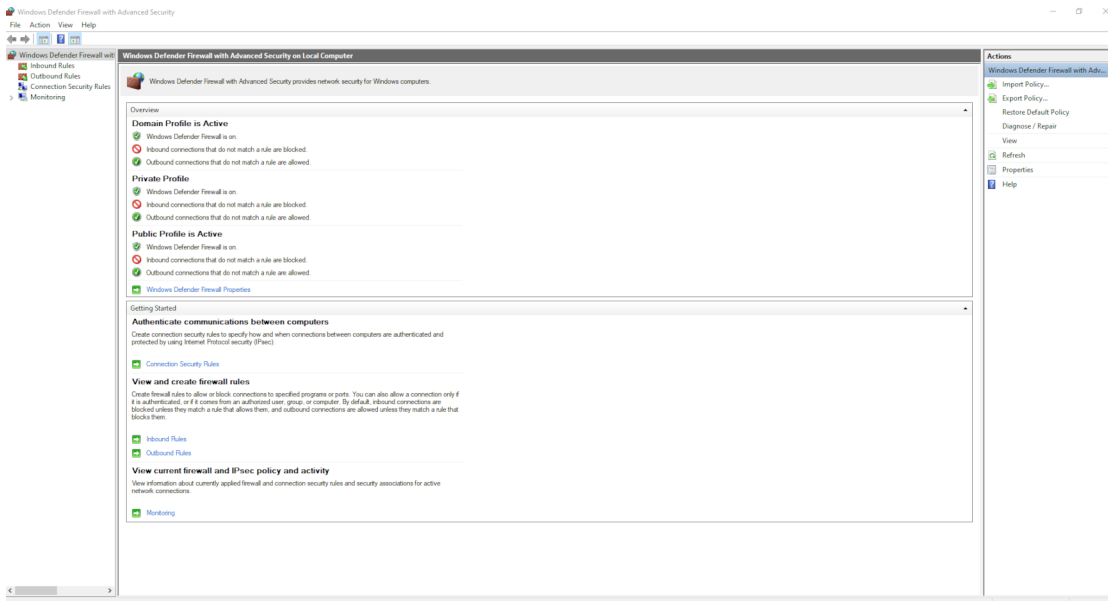

4. From the menu on the left, select *Inbound Rules*.
5. In the *Inbound Rules* window, according to your network topology, right-click *Windows Remote Management* and select *Enable Rule*.

Creating a privileged account

We create a new user belonging to the administrators groups.

To create a privileged account:

1. Go to *Control Panel > System and Security*.

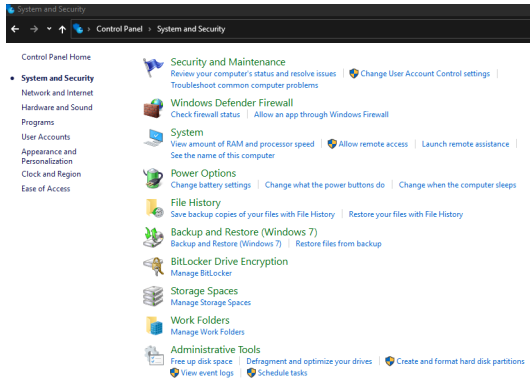

2. Click *Administrative Tools*.
3. In the *User Account Control* dialog that opens, click *Yes*.
A new window opens.

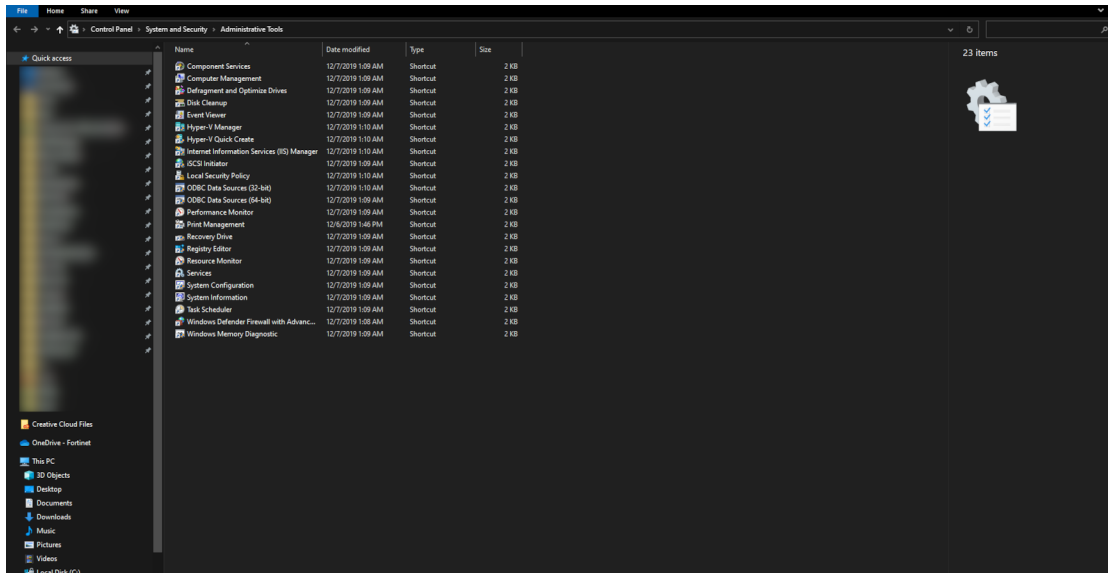

4. Double-click *Computer Management* to open it.
5. In the *User Account Control* dialog that opens, click *Yes*.
The *Computer Management* window opens.

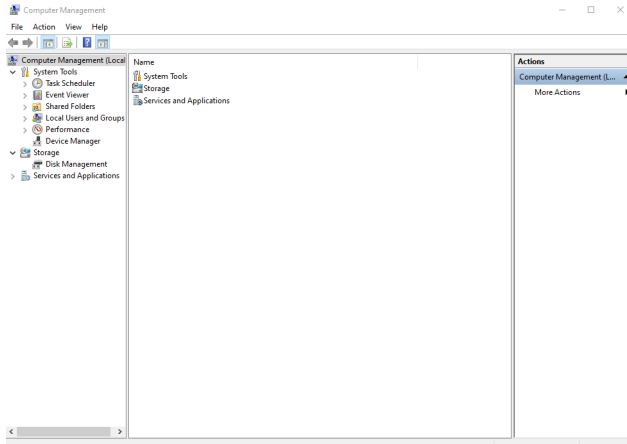

6. From the navigation pane on the left, select *Local Users and Groups*.

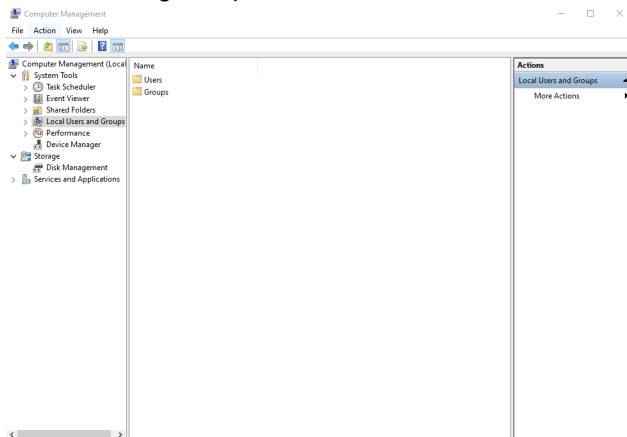

7. Right-click the *Users* folder and select *New User...*.
The *New User* dialog opens.

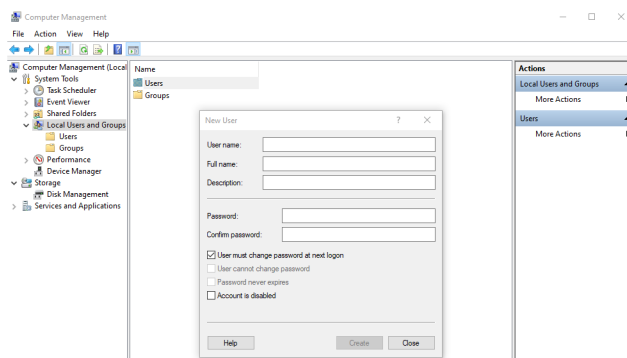

8. In the *New User* dialog:
 - a. In *User name*, enter a username.
 - b. In *Full name*, enter the full name of the user.
 - c. In *Description*, enter a description for the user.
 - d. In *Password*, enter a password.
 - e. In *Confirm password*, enter the password again to confirm.
 - f. Click *Create* to create the user.
9. Double-click the *Users* folder, right-click the user that was created in step 8, and select *Properties*.

10. In the new dialog that opens, go to the *Member Of* tab, select *Administrators*, and click *Add...*
11. Click *OK* to save changes.



If you intend to retrieve RDP logs for the privileged account, you must create a secret for the privileged account with a Windows target. See [Creating a secret on page 60](#).

Setting up audit policy for RDP log retrieval

To set up audit policy for RDP log retrieval:

1. Log in to the Windows machine to configure the policy as an administrator.
2. Go to *Control Panel > System and Security*.
3. Click *Administrative Tools* and in the new window that opens, double-click *Local Security Policy*.
4. In the the *User Account Control* dialog that opens, click *Yes*.

The *Local Security Policy* window opens.

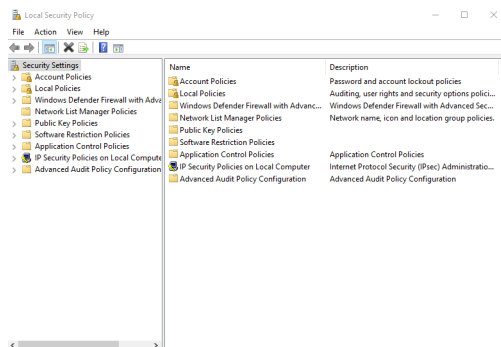

5. From the navigation pane on the left, expand *Local Policies > Audit Policy*.

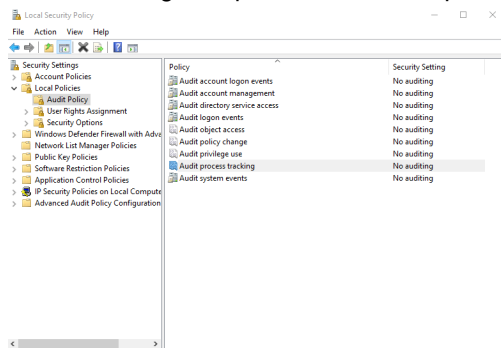

6. For the event filter profile that applies to the privileged account secret on FortiPAM:
 - a. If *Process Log* is set to *Monitor*, set *Audit process tracking* as success and failure by right-clicking *Audit process tracking*, selecting *Properties*, selecting *Success* and *Failure*, and clicking *OK*.
 - b. If *Filesystem Log* is set to *Monitor*, set *Audit object access* as success and failure by right-clicking *Audit object access*, selecting *Properties*, selecting *Success* and *Failure*, and clicking *OK*.



When you enable the policy to audit object access events, you must specify which files, folders, and user actions are logged.

You must be specific with the setting to avoid excessive logging.

- c. If *User Management Log* is set to *Monitor*, set *Audit account management* as success and failure by right-clicking *Audit account management*, selecting *Properties*, selecting *Success* and *Failure*, and clicking *OK*.
7. Log in to the Windows machine to configure policy and administrator privileges.
8. On the Windows machine, open *File Explorer*, right-click the file you intend to set the auditing policy for, and select *Properties*:
 - a. Go to the *Security* tab, click *Advanced*.
 - b. Go to the *Auditing* tab, click *Continue*.
 - c. In the *User Account Control* dialog, click *Yes*.
 - d. Click *Add*.



The *Add* button is labelled *Edit* on Windows 8.

- e. In the new window that opens, click *Select a principal*.
 - f. In *Select User, Computer, Service Account, or Group*, click *Advanced*.
 - g. Select users whose access to the file you want to monitor.
 - h. Click *OK*.
 - i. In the *Permissions* tab, set the permission for each of the user you have added.
 - j. Click *OK*.
9. Click *OK*.

The configuration is now complete. Windows will generate audit events when the users you have specified takes actions on the files or folders for which you have set up audit policies.

Appendix M: FortiPAM browser extension and standalone FortiClient air-gapped installation

To install FortiPAM browser extension:



The FortiPAM Firefox extension is installed automatically when you install the standalone FortiClient.

1. Go to [Fortinet Product Downloads center](#).
2. From the list, click *FortiPAM* to expand it.

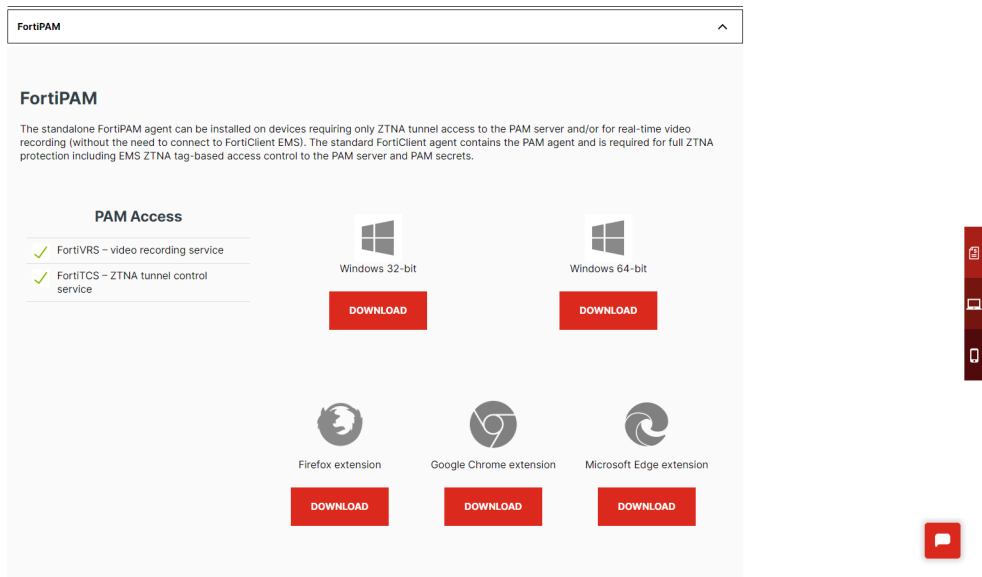

3. Click the *DOWNLOAD* button below the browser icon to download the required FortiPAM browser extension:
 - a. *Google Chrome*: `fortipam-chrome-extension.crx`
 - b. *Microsoft Edge*: `fortipam-edge-extension.crx`
 - c. *Mozilla Firefox*: `fortipam-firefox-extension.xpi`
4. Copy the downloaded FortiPAM browser extension file to the air-gapped computer.
5. On the air-gapped computer, in a web browser window, open the web extensions page using the following URL:
 - a. *Google Chrome*: `chrome://extensions`
 - b. *Microsoft Edge*: `edge://extensions`
 - c. *Mozilla Firefox*: `about:addons`
6. Enable *Developer mode* on the web browser and refresh the web page:
Note: On Mozilla Firefox, you do not need to explicitly enable the developer mode.

a. On Google Chrome:

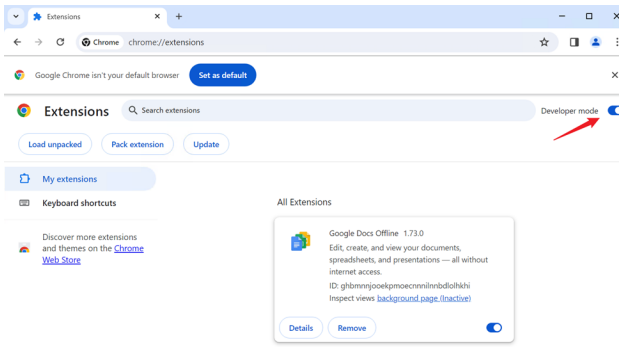

b. On Microsoft Edge:

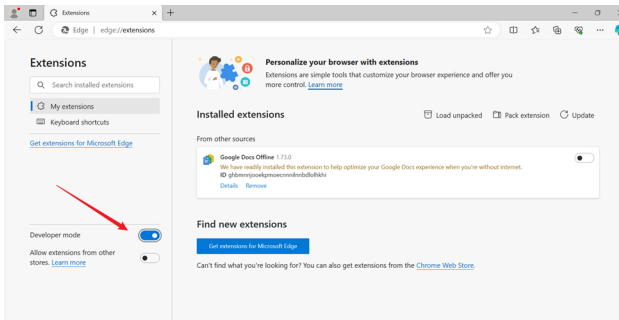

7. Drag and drop the FortiPAM browser extension file to the extension page, and install the browser extension by clicking *Add Extension*.

a. On Google Chrome:

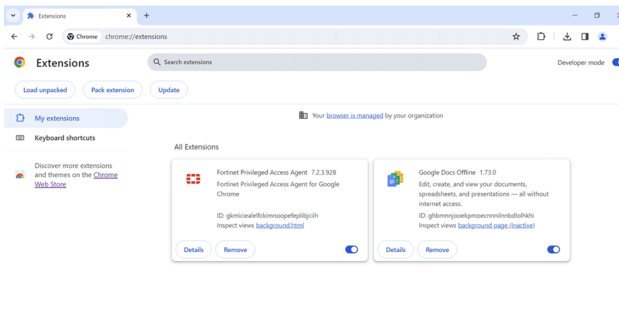

b. On Microsoft Edge:

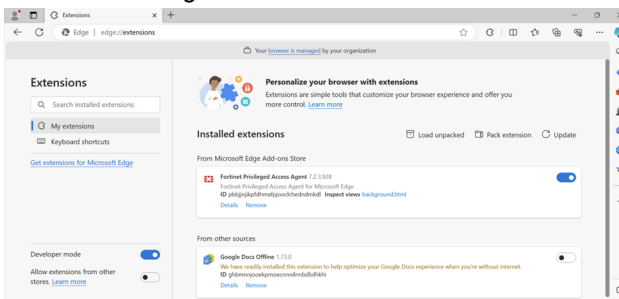

c. On Mozilla Firefox:

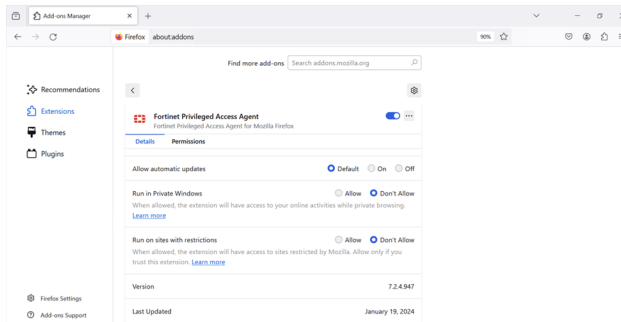

To install standalone FortiClient:



The standalone FortiClient requires FortiPAM browser extension to offer PAM related functionalities.

You must install FortiPAM browser extension.



The standalone FortiClient and the FortiPAM browser extension can be installed in any order.

1. Go to [Fortinet Product Downloads center](#).
2. From the list, click *FortiPAM* to expand it.
3. Click the **DOWNLOAD** button below *Windows 64-bit* or *Windows 32-bit* icon to download standalone FortiClient.
4. Copy the downloaded FortiClient installation file to the air-gapped computer.
5. On the air-gapped computer, double-click the FortiClient installation file to install it.

Appendix N: Performance test results

FortiPAM is a cutting edge platform that inherits the high performance design of the FortiOS platform.

The FortiPAM platform is capable of:

- Dynamically distributing tasks across multiple CPUs to load balance workload.
- Improves CPU performance by caching the frequently accessed data.
- Using asynchronous I/O techniques elevates hard disk and network performance.

FortiPAM-VM minimum requirements based on different user seats

SKU	Seats	vCPUs	Memory (GB)	Log disk (GB)	Video disk (GB)
FC1-10-PAVUL-591-02-12	<10	2	8	20	150
FC2-10-PAVUL-591-02-12	<25	4	8	40	300
FC3-10-PAVUL-591-02-12	<50	4	8	100	500
FC4-10-PAVUL-591-02-12	<100	8	16	200	1 TB
FC5-10-PAVUL-591-02-12	<250	16	16	400	1 TB



Larger log and video disks are preferred.

FortiPAM-VM performance as tested in the lab

VM configuration

Dell server

- PowerEdge R450 Server
- Intel Xeon Silver 4310 2.1G, 12C/24T, 10.4GT/s, 18M Cache, Turbo

CPU cores

- 16

Memory

- 16 GB

Results

Keep 1000 launching sessions of SSH and Web SSH

- SSH traffic speed: 1 ssh command/per session/per second
- Video recording: 60K bytes/per session/per second

CPU and Memory widget in the *Dashboard* page

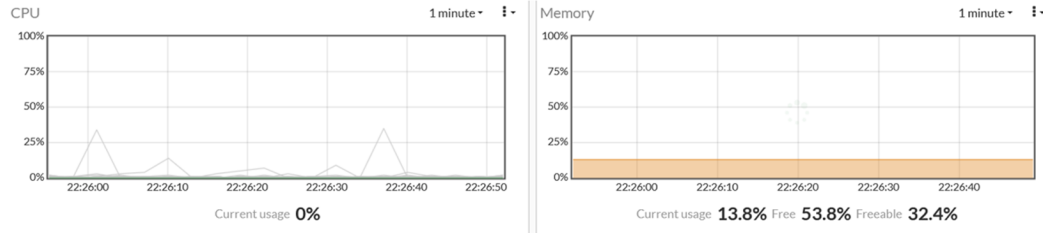

Note: The data was collected from the test performed in the FortiPAM lab.

Keep 90 launching session of Web RDP

- Video recording enabled
- Windows desktop page keeps refreshing the Task Manager window

CPU and Memory widget in the *Dashboard* page

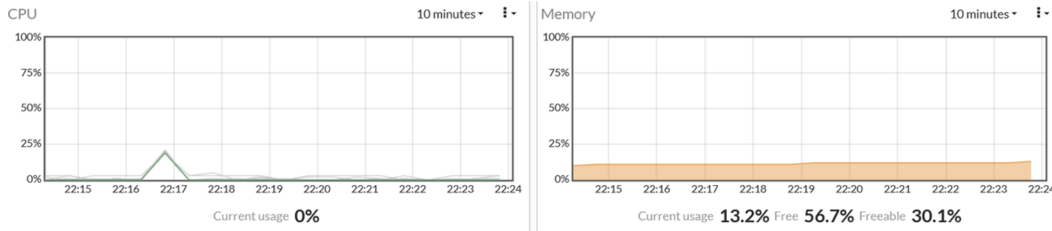

Note: The data was collected from the test performed in the FortiPAM lab.



www.fortinet.com

Copyright© 2025 Fortinet, Inc. All rights reserved. Fortinet®, FortiGate®, FortiCare® and FortiGuard®, and certain other marks are registered trademarks of Fortinet, Inc., and other Fortinet names herein may also be registered and/or common law trademarks of Fortinet. All other product or company names may be trademarks of their respective owners. Performance and other metrics contained herein were attained in internal lab tests under ideal conditions, and actual performance and other results may vary. Network variables, different network environments and other conditions may affect performance results. Nothing herein represents any binding commitment by Fortinet, and Fortinet disclaims all warranties, whether express or implied, except to the extent Fortinet enters a binding written contract, signed by Fortinet's General Counsel, with a purchaser that expressly warrants that the identified product will perform according to certain expressly-identified performance metrics and, in such event, only the specific performance metrics expressly identified in such binding written contract shall be binding on Fortinet. For absolute clarity, any such warranty will be limited to performance in the same ideal conditions as in Fortinet's internal lab tests. Fortinet disclaims in full any covenants, representations, and guarantees pursuant hereto, whether express or implied. Fortinet reserves the right to change, modify, transfer, or otherwise revise this publication without notice, and the most current version of the publication shall be applicable.